



■ **Elektrikli Zincirli Vinçler**
Electric Chain Hoists

■ **Havalı Vinçler**
Air Chain Hoists

■ **Manuel, Elektrikli ve Havalı Şaryolar**
Manuel, Electric and Air Trolleys

■ **Zincirli Ceraskallar**
Chain Hoist

■ **Zincirli Çektirmeler**
Lever Hoists

■ **Halatlı Çektirmeler**
Pulling Hoists

■ **Irgatlar**
Brake Winchs

CERASKAL ve VİNÇLER
HOISTS

ELEKTRİKLİ KANCALI ZİNCİRLİ VİNÇ / ELECTRIC CHAIN HOIST WITH HOOK

	NL-D 025 H	NL-D 050 H	NL-D 100 H	
Kaldırma kapasitesi / Capacity	250	500	1000	kg
Zincir donanı / No. of column of load chain	1	2	2	sıra
Standart kaldırma yüksekliği / Lifting height	6.5	6.5	6.5	m
Kaldırma hızı / Lifting speed	8/ 2,4	4/ 1,2	4/ 1,2	m/dk
Kaldırma motoru / Lifting motor	0,36/ 0,01	0,36/ 0,01	0,76/ 0,24	kw
Voltaj / Voltage	380	380	380	V
Vinç ağırlığı / Weight	28	34	63	kg

Not: Ray kısıkaçı opsiyonel seçenektir.

Note: Beam clamp is optional.

- Tüm modellerde kaldırma-indirme hareketi çift hızlı, yürütme tek hızlı
- In all the models lifting- lowering has double speed and travelling has single speed

- Konik rotor
- Çift hızlı
- DIN 5684 normunda zincir
- Limit şalterli (2 adet)
- Mekanik fren
- Kompakt dizayn
- Kolay servis ve bakım
- Kolay montaj ve demontaj

- Conical rotor
- Double speed
- DIN 5684 chain
- Limit switches (2 pieces)
- Mechanical brake
- Compact design
- Ease of service and maintenance
- Ease of mounting and dismounting



Art.No. 52500051	NL-D 025 H
Art.No. 52500052	NL-D 050 H
Art.No. 52500053	NL-D 100 H



Art.No. 52500057	NL-S 200 H
Art.No. 52500059	NL-D 200 H



ELEKTRİKLİ ZİNCİRLİ VİNÇ / ELECTRIC CHAIN HOIST

	NL-S 200 H Kancalı	NL-D 200 H Kancalı	
Kapasite / Capacity	2000	2000	kg
Kaldırma hızı / Lifting speed	4	4/1	m/dk
Yürüyüş hızı / Travelling speed	-	-	m/dk
Kaldırma motoru / Lifting motor	1.5	1.5/ 0.33	kw
Yürüyüş motoru / Driving motor	-	-	kw
Zincir donanı / No of column of load chain	2	2	
Zincir çapı / Chain diameter	9 x 27	9 x 27	mm
Kaldırma yüksekliği / Lifting height	6	6	m
Profil çalışma aralığı / I - beam range	-	-	
Min. dönme yarıçapı / Min. turning radius	-	-	m
Ağırlık / Weight	135	172	kg
Voltaj / Voltage	380		V

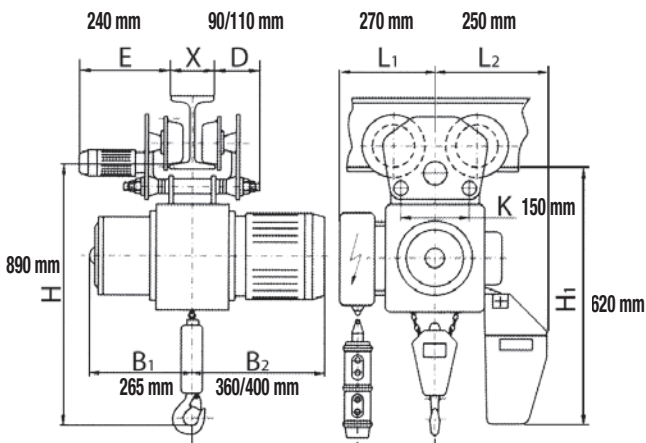

Elektrikli Şaryo / Electric Trolley (ET Serisi/ Series)

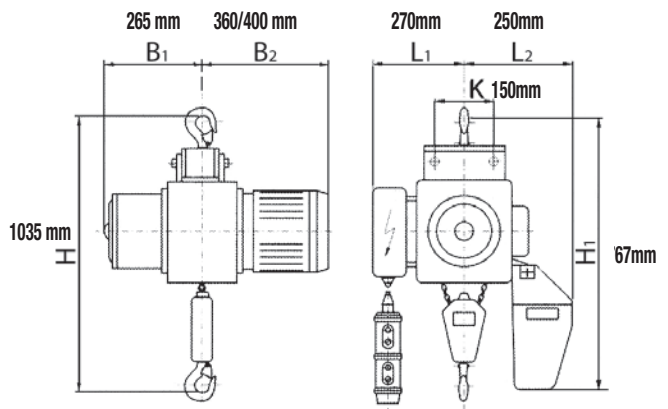

Kancalı / Upper hook (H Serisi/ Series)

ELEKTRİKLİ ZİNCİRLİ VİNÇ (NLXN) / ELECTRIC CHAIN HOIST (NLXN)

- Yükleme aralığı FEM 2m/ ISO M5' e tekabül ettiği için geniş bir uygulama alanı sağlamakta.
- Yüksek hız ile minimum hız aralığı ayarlanabilir oluşu itibarı ile kesin ve detaylı bir yükleme imkanı sunmakta.
- 48 Volt ile çalışması sonucu güvenli bir kullanım sağlamakta.
- Dayanıklı alüminyumdan üretilmiş olan zincir çantası çok sık kullanımlara uygun olarak tasarlanıp imal edilmiştir.
- Standart asmalı ürünlerimiz düz, alçak tavan ceraskal, yürütmeli arabalı ve alçak yürütme arabalı ürünlerimiz bulunmaktadır.

- Load spectrum conforms to FEM 2m/ ISO M5 covering a wide range of applications.
- Speed ratio of 4:1 clearly delineates between high speed and low speed, providing the precise load spotting capacities required in many applications.
- 48V control voltage for operator safety.
- The rugged aluminum alloy casting is engineered to withstand the rigors of repeated lifting cycles.
- Standard suspensions include Plain Trolley (PT), Low headroom Plain Trolley (LPT), Geared Trolley (GT), Low headroom Geared Trolley (LGT) and motorized Trolley.



Örnek Uygulamalar / Sample Applications



İstenilen uzunlukta zincir temin edilebilmektedir.

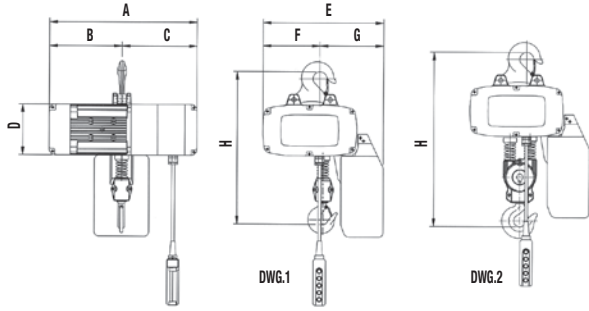

Kod No Code No	Model	Çalışma Yük Limiti WLL (kg)	Kaldırma Yükseklği Lifting Height (m)	DWG No	Boyutlar Dimensions (mm)								Yük Zinciri Load Chain Çap x iç uzunluk Dia x pitch	Kaldırma Hızı ve Motor Gücü / Hoisting Speed and Motor Power 50Hz		Yürütme Hızı ve Motor Gücü/ Travelling Speed and Motor Power 50Hz		Enerji Energy (V/Hz)	E.D Oranı %	Donam/ Load Chain Fall No	Net Ağırlık/ Brüt Ağırlık/ N.W/G. W (kg)
					A	B	C	D	E	F	G	H		Çift Hız/ Dual Spd. m / dk	Motor Gücü/ Motor Power kw	Çift Hız/ Dual Spd. m / dk	Motor Gücü/ Motor Power kw				
71301251	NLXN-251	250	3	1	380	175	205	135	299	143	156	376	Φ 4.0x12.0	12/2.7	0.6/0.15	20/5	0.12/0.03	380/50	40/20	1	30/ 42
71301501	NLXN-501	500	3	1	468	221	247	156	366	186	180	485	Φ 6.3x19.1	10/2.5	1.1/0.28	20/5	0.18/0.04	380/50	40/20	1	42/ 57
71311002	NLXN-1002	1000	3	2	468	221	247	156	366	186	180	531	Φ 6.3x19.1	5/1.25	2/8P	20/5	2/8P	380/50	40/20	2	45/ 60
71311001	NLXN-1001	1000	3	1	488	240	248	170	398	188	210	520	Φ 7.1x20.2	8/2	1.5/0.37	20/5	0.37/0.09	380/50	40/20	1	57/ 77
71312002	NLXN-2002	2000	3	2	488	240	248	170	398	188	210	592	Φ 7.1x20.2	4/1	2/8P	20/5	2/8P	380/50	40/20	2	62/ 82

ELEKTRİKLİ ŞARYO (NLXT) / ELECTRIC TROLLEY (NLXT)

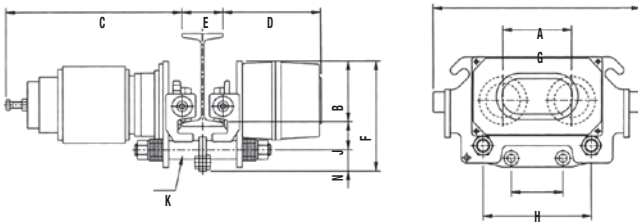

ELEKTRİKLİ ŞARYO (NLXT) / ELECTRIC TROLLEY (NLXT)



Kod No Code No	Model	Boyutlar / Dimensions (mm)											Hız Speed (m / dk) 50 Hz	Motor (m / dk)	Enerji Energy (V/Hz)	Net Ağırlık/ N.W (kg)	Min Dönüş RADIUS/ Min. radius curve (m)				
		A	B	C	D	E	F	G	H	L	J	N						K			
71401501	NLXT-0501																				
71420501	NLXTD-0501	382	111.5	324	180	75~125	202	125.5	95.5	200	51.5	39	7/8"-9UNC (φ 22.2)	20/5	0.12/0.03 - 2/8P	380/50	45	1.3			
71411001	NLXT-1001																				
71421001	NLXTD-1001	382	111.5	324	180	75~125	202	125.5	120	200	51.5	39	7/8"-9UNC (φ 22.2)	20/5	0.18/0.04 - 2/8P	380/50	45	1.3			
71411002	NLXT-1002																				
71421002	NLXTD-1002	382	111.5	324	180	75~125	202	125.5	95.5	200	51.5	39	7/8"-9UNC (φ 22.2)	20/5	0.18/0.04 - 2/8P	380/50	45	1.3			
71412002	NLXT-2002																				
71422002	NLXTD-2002	392	125	357	183	100~150	221	159	120	230	60	36	1"-8UNC (φ 25.4)	20/5	0.37/0.09 - 2/8P	380/50	50	1.7			

ELEKTRİKLİ ZİNCİRLİ VİNÇ (Classic) / ELECTRIC CHAIN HOIST (Classic)

* Dual Speed E.D Rating: 40/ 120 * Çift Hız E.D Oranı: 40/ 120

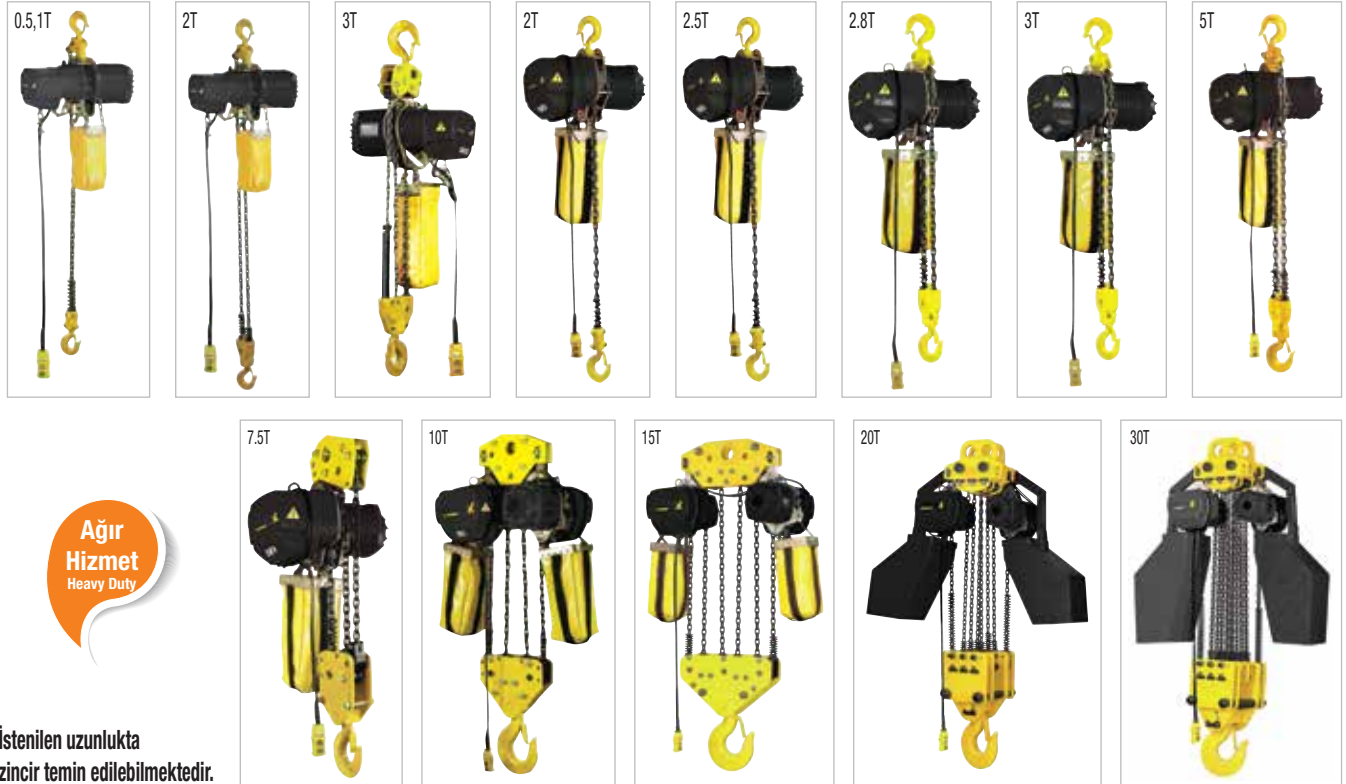

İstenilen uzunlukta zincir temin edilebilmektedir.

Kod No Code No	Model	Kaldırma Kapasitesi Lifting Capacity (SWL)	Kaldırma Hızı Lifting Speed (m / dk)	Zincir Çapı Chain Diam. (mm)	Zincir Donanı Load Chain Fall No	Kaldırma Yüksekliği Lifting Height (m)	Motor Gücü Motor Power (kW)	E.D. Oranı E.D Rating (%)	Enerji/ Energy (V)	Ağırlık Weight (kg)	Ambalaj Boyutları Packaging LxWxH (cm)
71100500	NSL050	0,5t	6,7	7,1	1	3 m	1,8	40	380 / 50 Hz	55	60 x 57 x 33
71100501	NSH050	0,5t	9,2	7,1	1	3 m	1,8	40	380 / 50 Hz	55	60 x 57 x 33
71100506	NSLD050	0,5t	6,7 / 2,2	7,1	1	3 m	1,8 / 0,6	40	380 / 50 Hz	55	60 x 57 x 33
71100507	NSHD050	0,5t	9,2 / 3,1	7,1	1	3 m	1,8 / 0,6	40	380 / 50 Hz	55	60 x 57 x 33
71100503	NSF050	0,5t	6,7	7,1	1	3 m	1,8	15	220 / 50 Hz	55	60 x 57 x 33
71101000	NSL100	1t	4,7	7,1	1	3 m	1,8	40	380 / 50 Hz	55	60 x 57 x 33
71101001	NSH100	1t	6,7	7,1	1	3 m	1,8	40	380 / 50 Hz	55	60 x 57 x 33
71101006	NSLD100	1t	4,7 / 1,6	7,1	1	3 m	1,8 / 0,6	40	380 / 50 Hz	55	60 x 57 x 33
71101007	NSHD100	1t	6,7 / 2,2	7,1	1	3 m	1,8 / 0,6	40	380 / 50 Hz	55	60 x 57 x 33
71101003	NSF100	1t	6,7	7,1	1	3 m	1,8	15	220 / 50 Hz	55	60 x 57 x 33
71102000	NSL200	2t	2,3	7,1	2	3 m	1,8	40	380 / 50 Hz	61	60 x 57 x 33
71102001	NSH200	2t	3,3	7,1	2	3 m	1,8	40	380 / 50 Hz	61	60 x 57 x 33
71102014	NSLD200	2t	2,3 / 0,8	7,1	2	3 m	1,8 / 0,6	40	380 / 50 Hz	61	60 x 57 x 33
71102009	NSHD200	2t	3,3 / 1,1	7,1	2	3 m	1,8 / 0,6	40	380 / 50 Hz	61	60 x 57 x 33
71102004	NSF200	2t	2,3	7,1	2	3 m	1,8	15	220 / 50 Hz	61	60 x 57 x 33
71103000	NSL300	3t	1,5	7,1	3	3 m	1,8	40	380 / 50 Hz	73	62 x 62 x 50
71103001	NSH300	3t	2,2	7,1	3	3 m	1,8	40	380 / 50 Hz	73	62 x 62 x 50
71103002	NSLD300	3t	1,5 / 0,5	7,1	3	3 m	1,8 / 0,6	40	380 / 50 Hz	73	62 x 62 x 50
71103003	NSHD300	3t	2,2 / 0,7	7,1	3	3 m	1,8 / 0,6	40	380 / 50 Hz	73	62 x 62 x 50
71102010	NSSD200	2t	6,6 / 2,2	10	1	3 m	3,7 / 1,2	40	380 / 50 Hz	125	73 x 57 x 41
71102002	NSS200	2t	6,6	10	1	3 m	3,7 / 1,2	40	380 / 50 Hz	125	73 x 57 x 41
71102500	NSS250	2,5t	5,2	11,2	1	3 m	3,7	40	380 / 50 Hz	130	73 x 57 x 41
71102501	NSSD250	2,5t	5,2 / 1,7	11,2	1	3 m	3,7 / 1,2	40	380 / 50 Hz	130	73 x 57 x 41
71103004	NSS300	3t	4,3	10	2	3 m	3,7	40	380 / 50 Hz	140	73 x 57 x 41
71103005	NSSD300	3t	4,3 / 1,4	10	2	3 m	3,7 / 1,2	40	380 / 50 Hz	140	73 x 57 x 41
71105000	NSS500	5t	2,6	11,2	2	3 m	3,7	40	380 / 50 Hz	153	73 x 57 x 41
71105001	NSSD500	5t	2,6 / 0,9	11,2	2	3 m	3,7 / 1,2	40	380 / 50 Hz	153	73 x 57 x 41
71107500	NSS750	7,5t	1,8	11,2	3	3 m	3,7	40	380 / 50 Hz	195	73 x 57 x 41
71107501	NSSD750	7,5t	1,8 / 0,6	11,2	3	3 m	3,7 / 1,2	40	380 / 50 Hz	195	73 x 57 x 41
71110000	NSS1000	10t	2,6	11,2	4	3 m	3,7 x 2	40	380 / 50 Hz	410	86 x 85 x 75
71110001	NSSD1000	10t	2,6 / 0,9	11,2	4	3 m	3,7x2 / 1,2x2	40	380 / 50 Hz	410	86 x 85 x 75
71115000	NSS1500	15t	1,8	11,2	6	3 m	5 x 2	40	380 / 50 Hz	510	140 x 85 x 97
71115001	NSSD1500	15t	1,8 / 0,6	11,2	6	3 m	5x2/1,7x2	40	380 / 50 Hz	510	140 x 85 x 97
71120000	NSS2000	20t	1,3	11,2	8	3 m	5 x 2	40	380 / 50 Hz	890	170x105x167
71120001	NSSD2000	20t	1,3 / 0,43	11,2	8	3 m	5x2/1,7x2	40	380 / 50 Hz	890	170x105x167
71130000	NSS3000	30t	0,9	11,2	12	3 m	5 x 2	40	380 / 50 Hz	1035	170x105x167
71130001	NSSD3000	30t	0,9 / 0,3	11,2	12	3 m	5x2/1,7x2	40	380 / 50 Hz	1035	170x105x167

Ölçüler / Dimensions

Model	Kapasite Capacity (ton)	Boyutlar Dimensions (mm)												
		H (mm)	A (mm)	B (mm)	C (mm)	D (mm)	E (mm)	F (mm)	I (mm)	J (mm)	K (mm)	L (mm)	M (mm)	N (mm)
NSL050, NSH050, NSLD050, NSHD050, NSF050	0.5	570	505	245	260	240	115	125	40	28	40	28	23	23
NSL100, NSH100, NSLD100, NSHD100, NSF100	1	570	505	245	260	240	115	125	40	28	40	28	23	23
NSL200, NSH200, NSLD200, NSHD200, NSF200	2	700	505	245	260	240	175	65	46	36	46	36	31	31
NSL300, NSH300, NSLD300, NSHD300	3	880	505	245	260	280	175	105	52	43	52	43	34	34
NSSD200, NSS200,	2	835	640	326	314	448	278	170	52	43	52	43	34	34
NSS250, NSSD250	2.5	880	640	326	314	448	278	170	52	43	52	43	34	34
NSS300, NSSD300	3	960	640	326	314	448	340	108	52	43	52	43	34	34
NSS500, NSSD500	5	1030	640	326	314	448	356	92	62	45	62	45	45	45
NSS750, NSSD750	7.5	1050	640	326	314	587	388	199	72	40	75	57	84	48
NSS1000, NSSD1000	10	1270	640	326	314	970	485	485	72	40	100	68	92	60
NSS1500, NSSD1500	15	1365	640	326	314	1360	680	680	80	40	120	90	169	85
NSS2000, NSSD2000	20	1700	866	433	433	1472	736	736	82	82	140	95	164	95
NSS3000, NSSD3000	30	1700	924	462	462	1472	736	736	92	92	140	95	221	95

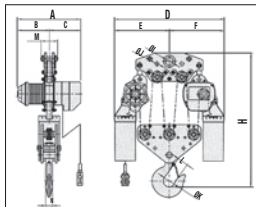
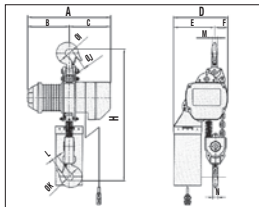
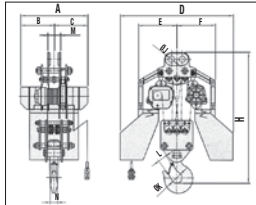
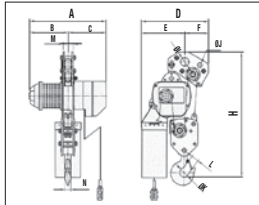
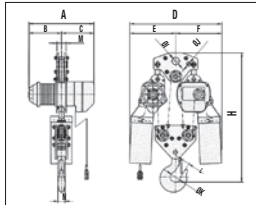
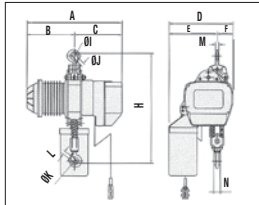

"Netlift BLACX" Elektrikli Vinçlerin Avantajları:

- 24/48 volta dönüştürülmüş elektrik akımı özellikle nemli bölgelerde yanlış kullanımlarda anında müdahale imkânını vermekte.
- Otomatik fren sistemi ani elektrik kesintilerinde veya ürünün kapanmasında anında fren sistemi devreye girmekte.
- İkili fren sistemi daha emniyetli bir kullanımı sağlamakta.
- Limit dümesi zincirin gereksiz yer boşalmasını engellemekte.
- İleri teknoloji hata tespit röleleri motoru yanlış elektrik akımlarında korumaya alıp, hareket ettirmemekte.
- Acil durum freni opsiyonel olarak mevcuttur.
- Elektronik aşırı yüklenme koruması opsiyonel olarak mevcuttur.

"Netlift BLACX" Advantages of Electric Chain Hoist:

- Pendant control voltage transformed into 24V/48V to eliminate possible accident caused by circuit short and assure safe operation in wet environments.
- Automatic motor brake system features simultaneous braking upon power failure or switching off.
- Dual brake system assures safe operation.
- Limit switches hold chain from running out.
- Advanced phase error relay keeps motor motionless at incorrect power connection
- Optional emergency stop features available.
- Optional electronic overload protection available.

ELEKTRİKLİ ŞARYO (Classic MT) /
ELECTRIC TROLLEY (Classic MT)

ELEKTRİKLİ ŞARYO (Classic MT) / ELECTRIC TROLLEY (Classic MT)

Kod No Code No	Model	Kapasite Capacity (ton)	Flanş Genişliği Flange Width (E)	Hız Speed (m / dk)	Motor (kw)	Enerji Energy	Kutup Pole (kw)	Min. Dönüş Çapı Min. Radius (m)	Ağırlık Weight (kg)
				50 Hz					
712 01 000	MT-100	1	75-125	20	0,25	380 V / 50Hz	4,6	1,3	40
712 01 003	MTD-100	1	75-125	20/7	0,25/0,08	380 V / 50Hz	4/12	1,3	40
712 01 002	MTF-100	1	75-125	20	0,25	220 V / 50Hz	4,6	1,3	40
712 02 000	MT-200	2	100-150	20	0,25	380 V / 50Hz	4,6	1,5	45
712 02 003	MTD-200	2	100-150	20/7	0,25/0,08	380 V / 50Hz	4/12	1,5	45
712 02 002	MTF-200	2	100-150	20	0,25	220 V / 50Hz	4,6	1,5	45
712 03 000	MT-300	3	125-175	20	0,6	380 V / 50Hz	4,6	1,8	65
712 03 001	MTD-300	3	125-175	20/7	0,6/0,2	380 V / 50Hz	4/12	1,8	65
712 05 000	MT-500	5	125-175	20	0,6	380 V / 50Hz	4,6	2,0	89
712 05 001	MTD-500	5	125-175	20/7	0,6/0,2	380 V / 50Hz	4/12	2,0	89
712 07 500	MT-750	7.5	150-200	13	0,9	380 V / 50Hz	6	3,0	155
712 07 501	MTD-750	7.5	150-200	13/6.5	0,9/0,45	380 V / 50Hz	6/12	3,0	155
712 10 000	MT-1000	10	150-200	14	1,5	380 V / 50Hz	6	3,5	218
712 10 001	MTD-1000	10	150-200	14/7	1,5/0,75	380 V / 50Hz	6/12	3,5	218
712 15 000	MT-1500	15	190	10	1,5	380 V / 50Hz	6	-	350
712 15 001	MTD-1500	15	190	10/5	1,5/0,75	380 V / 50Hz	6/12	-	350
712 20 000	MT-2000	20	200	12	2,2	380 V / 50Hz	4	-	575
712 20 001	MTD-2000	20	200	12/4	2,2/0,73	380 V / 50Hz	4/12	-	575
712 30 000	MT-3000	30	200	12	2,2	380 V / 50Hz	-	-	-
712 30 001	MTD-3000	30	200	12/4	2,2/0,73	380 V / 50Hz	-	-	-

NOT: MT modeli tek hız, MTD modeli çift hızdır.

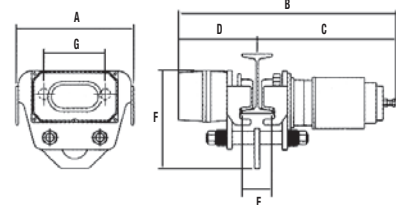

Ölçüler / Dimensions

Kapasite Capacity (ton)	Boyutlar Dimensions					
	A (mm)	B (mm)	C (mm)	D (mm)	F (mm)	G (mm)
1	295	541	345	196	246	149
2	323	567	358	209	272	161
3	359	662	417	245	297	172
5	389	673	422	251	320	183
7.5	454	736	465	271	530	228.3
10	560	821	550	271	565	277.3
15	692	878	589	289	530	353
20	882	1025	719	306	604	439.6

ALÇAK TAVAN VİNCİ - ELEKTRİK ŞARLOYU / HEADROOM HOIST - ELECTRIC TROLLEY

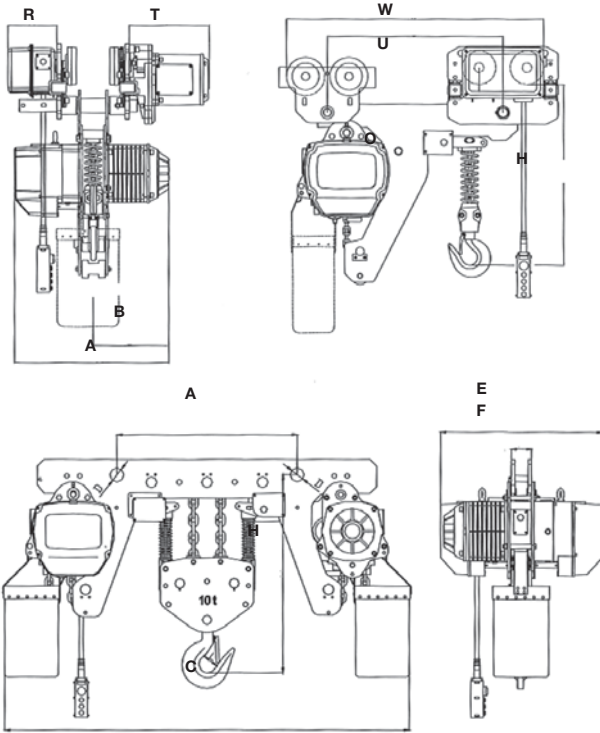

Alçak Tavan
Low Headroom

Kod No Code No	Model	Kapasite Capacity (ton)	Kaldırma Hızı min./max. Lifting Speed min./max (m / dk)	Motor Gücü Motor power (kw)	Rotasyon Hızı Rotation speed (r/min)	Güç Kaynağı Power Supply	Voltaj Voltage (V)	Kaldırma Yükseklığı Lifting Height (m)	Donam No of chain	Zincir Çapı Chain Diam. (mm)	Boyutlar / Dimensions (mm)				
											H	A	B	W	U
71100504	NL-SSDHL 0.5-01	0.5	7.2 / 2.4	0.8 / 0.27	2880 / 960	3P 380V	24 / 36 / 48	5	1	Ø 6.3	400	545	260	585	400
71101004	NL-SSDHL 0.1-01	1	6.9 / 2.3	1.8 / 0.6					1	Ø 7.1	480	582	280	630	445
71101504	NL-SSDHL 1.5-01	1.5	9.0 / 3.0	3.0 / 1.0					1	Ø 10.0	570	670	313	720	505
71102005	NL-SSDHL 2.0-01	2	6.9 / 2.3	3.0 / 1.0					1	Ø 10.0	570	670	313	720	505
71102008	NL-SSDHL 2.0-02	2	3.3 / 1.1	1.8 / 0.6					2	Ø 7.1	535	582	280	665	445
71102505	NL-SSDHL 2.5-01	2.5	5.4 / 1.8	3.0 / 1.0					1	Ø 11.2	640	670	313	775	526
71103007	NL-SSDHL 3.0-01	3	5.4 / 1.8	3.0 / 1.0					1	Ø 11.2	640	670	313	775	526
71103008	NL-SSDHL 3.0-02	3	4.5 / 1.5	3.0 / 1.0					2	Ø 10.0	685	670	313	750	503
71105002	NL-SSDHL 5.0-02	5	2.7 / 0.9	3.0 / 1.0					2	Ø 7.1	740	670	313	825	541
71107503	NL-SSDHL 7.5-03	7.5	1.8 / 0.6	3.0 / 1.0					3	Ø 11.2	890	670	313	1020	730
71110004	NL-SSDHL 10.0-04	10	2.7 / 0.9	3.0 / 1.0					4	Ø 11.2	850	670	313	996	700

* Tek hızlı seçenekleri mevcuttur.

ELEKTRİK ŞARYO ÖLÇÜLERİ / ELECTRIC TROLLEY DIMENSIONS

Kapasite Capacity (ton)	Boyutlar / Dimensions (mm)				Hız Speed min./max (m / dk)	Motor Motor (kw)	Min. Dönme çapı Min. radius of turn
	W	U	R	T			
0.5	315	212	142	231	21	0.4	0.8
1	315	212	142	231		0.4	0.8
2	325	220	142	231		0.4	0.9
3	340	250	142	231		0.75	1.0
5	400	291	142	231		0.75	1.5
7.5	400	291	142	231		0.75	1.8
10	500	371	142	231		0.75	2.0

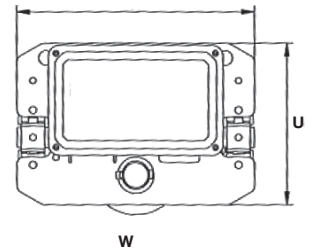
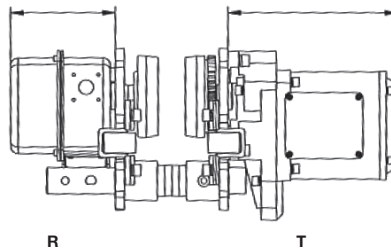

HAVALI ZİNCİRLİ VİNÇ / AIR CHAIN HOIST

Kod No Code No	Model	Kapasite Capacity (kg)	Kaldırma Yüksekliği Lifting Height (m)	Sınıflandırma Classification	Çalıştırma Operation	Motor (kw)	Hava Basıncı Air Supply Pressure (kg/cm ²)	Donam no Fall no.	Yük zinciri Load Chain (mm)	Hız Speed (m/dk)	Hava Tüketimi Air Consumption (m ³ / dk)	Yalıtım Korunması Insulation protection	Fren Tipi Brake Type	Anahtar Limit Switch	Hava Giriş Air Inlet (in)	Gürültü Seviyesi Level of Noise (dB)	Ana Hava Tedarik Hatlı Main Line Air Supply
71100525	NSA-025	250	3	FEM 2m		1.5	6 (85PSI)	1	6.3 x 19.1	18	2	IP 54	Disk Fren/ Disk type brake	Üst / Alt Limit/ Upper / lower limit	1/2"	85	3/4"
71100526	NSA-050	500				1		6.3 x 19.1	11	2	1/2"				85	3/4"	
71100527	NSA-100	1000				1		7.1 x 20.2	7.6	2	1/2"				85	3/4"	
71100528	NSA-200	2000				2		7.1 x 20.2	3.8	2	1/2"				85	3/4"	
71100529	NSA-320	3200				1		13 x 36	4.8	4	3/4"				90	2"	
71100530	NSA-630	6300				2		13 x 36	2.4	4	3/4"				90	2"	

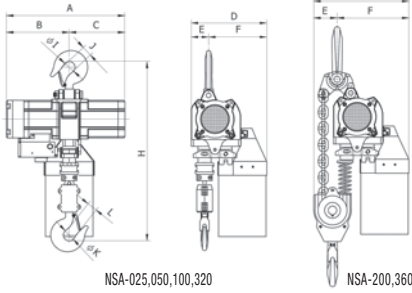

NSA-025,050,100,320

NSA-200,360

Ölçüler / Dimensions

Kapasite Capacity (kg)	Boyutlar Dimensions										
	H (mm)	A (mm)	B (mm)	C (mm)	D (mm)	E (mm)	F (mm)	I (mm)	J (mm)	K (mm)	L (mm)
250	535	371	197	174	244	70	174	40	32	40	32
500	535	402	228	174	244	70	174	40	32	40	32
1000	540	460	255	205	251	65	186	40	32	40	32
2000	760	460	255	205	319	73	246	46	40	46	40
3200	792	523.5	277.5	246	334	77	257	52	47	52	47
6300	1013	523.5	277.5	246	421	104	317	62	52	62	52

HAVALI ŞARYO / AIR TROLLEY

HAVALI ŞARYO / AIR TROLLEY

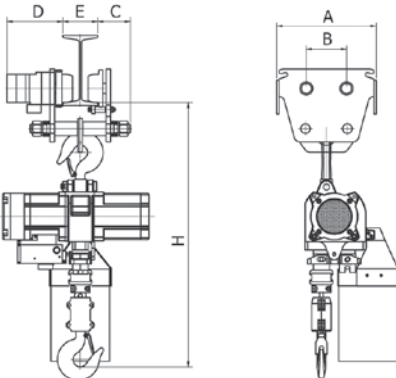

Kod No Code No	Şaryo Modeli Trolley model	Kapasite Capacity (kg)	Motor (kw)	Hava Basıncı Air supply pressure (kg/cm ²)	Yürüyüş Hızı Traversing (m/ dk)	Fren Tipi Brake type	Hava Giriş Air inlet (in)
71400500	AT 100	1000	0.2	6	20	Disk tipi fren/ Disk type brake	1/2"
71400501	AT 200	2000	0.2	6	20	Disk tipi fren/ Disk type brake	1/2"
71400502	AT 320	3200	0.2	6	20	Disk tipi fren/ Disk type brake	1/2"
71400503	AT 630	6300	0.2	6	6	Disk tipi fren/ Disk type brake	1/2"

HAVALI VİNÇ ve ŞARYO KOMBİNASYONU- ÖLÇÜLER /
COMBINATION OF AIR CHAIN HOIST AND AIR TROLLEY

Model	Kapasite Capacity (kg)	Boyutlar Dimensions					
		H (mm)	A (mm)	B (mm)	C (mm)	D (mm)	E (mm)
NSA-025 + PT 050*	250	608	194	89	35	-	50-150
NSA-050 + PT 050*	500	608	194	89	35	-	50-150
NSA-100 + AT 100	1000	645.5	294	116	95	208	75-125
NSA-200 + AT 200	2000	785.5	322	135	100	209.5	100-150
NSA-320 + AT 320	3200	902	356	144	117.5	217	125-175
NSA-630 + AT 630	6300	1125	386	183	132.5	219	125-175

* Manuel Şaryo / Plain Trolley

ZİNCİRLİ CERASKAL (BLACK AĞIR HİZMET ZİNCİRLİ CERASKALLARI) / CHAIN HOIST (BLACK HEAVY DUTY CHAIN HOIST)

Kod No Code No	Model	Kapasite Capacity (ton)	S.W.L Güvenli Çalışma Yüğü Safe Working Load (kg)	Test Yüğü Test Load (ton)	Standart Kaldırma Yükseklığı Standard Lifting Height (m)	Yük Zinciri Çapı Load Chain Diameter (mm)	Yük Zincir Donamı Load Chain Fall	Çekme Gücü Pulling Efforts (kg)	Ceraskal Yükseklığı Head Room (mm) (G)	Net Ağırlık Net Weight (kg)	Brüt Ağırlık Gross Weight (kg)
71700005	BX-0.5	0.5	500	0.75	5	6.3	1	21	305	10.3	10.8
71700005-1	BX-0.5 yük limitörlü										
71700100	BX-1	1	1000	1.50	5	6.3	1	25	340	11.1	11.7
71700100-1	BX-1 yük limitörlü										
71700150	BX-1.5	1.5	1500	2.25	5	7.1	1	32	385	15.5	16.3
71700150-1	BX-1.5 yük limitörlü										
71700200	BX-2	2	2000	3.0	5	8.0	1	34	420	19.7	20.6
71700200-1	BX-2 yük limitörlü										
71700300	BX-3	3	3000	4.50	5	7.1	2	34	465	23.4	24.4
71700300-1	BX-3 yük limitörlü										
71700301	BX-3 / 1	3	3000	4.50	5	10	1	38	550	30.7	32.3
71700302	BX-3/ 1	3	3000	4.50	10	10	1	38	550	30.7	32.3
71700500	BX-5	5	5000	7.5	5	8.0	3	37	575	37.8	39.6
71700500-1	BX-5 yük limitörlü										
71701000	BX-10	10	10000	15	5	10	3	40	660	69.3	73.2

**Ağır
Hizmet
Heavy Duty**



Kapasite Capacity (ton)	Boyutlar Dimensions							
	A (mm)	B (mm)	D (mm)	E (mm)	N (mm)	F (mm)	F1 (mm)	G (mm)
1.50	89	67	50	80	2650	30	26	305
1	89	67	63	87	2660	33	28	340
1.5	93	73	75	105	2660	38	34	385
2	98	77	85	115	2665	43	38	420
3	93	73	60	150	2675	43	38	465
5	98	77	120	210	2750	57	52	575

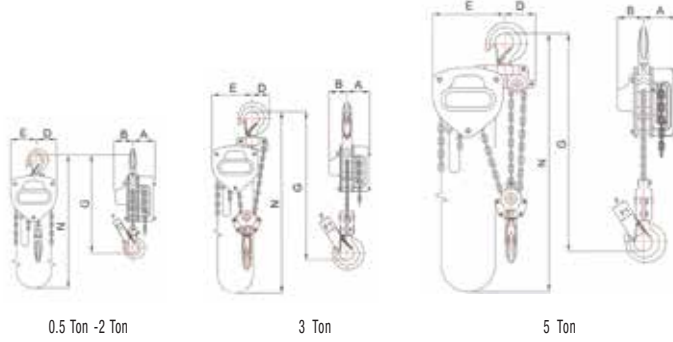

0.5 Ton - 2 Ton

3 Ton

5 Ton

ZİNCİRLİ ÇEKTİRME (BLACK AĞIR HİZMET ZİNCİRLİ ÇEKTİRMELER) / LEVER HOIST (BLACK HEAVY DUTY LEVER HOIST)

Kod No Code No	Model	Kapasite Capacity (ton)	Çektirme mesafesi Pulling Distance (m)	Test Yüğü Test Load (kg)	Tam Yükle Harcanan Efor Pull On Lever To Lift Full Load (kg)	Yük Zinciri Çapı Load Chain Diameter (mm)	Zincir Donamı Load Chain Fall No	Net Ağırlık Net Weight (kg)	Brüt Ağırlık Gross Weight (kg)
71710025	BXL-0.25	1/4	1.0	250	30	F 4.0	1	2	2.15
71710050	BXL-0.5	1/2	1.0	500	34	F 0.5	1	3.6	3.9
71710075	BXL-0.75	3/4	1.5	1125	22	F 6.3	1	6.9	7.38
71710075-1	BXL-0.75 yük limitörlü								
71710100	BXL-1	1	1.5	1500	29	F 6.3	1	7.2	7.68
71710100-1	BXL-1 yük limitörlü								
71710150	BXL-1.5	1/1.2	1.5	2250	26	F 7.1	1	10	10.75
71710150-1	BXL-1.5 yük limitörlü								
71710300	BXL-3	3	1.5	4500	38	F 10	1	17.7	18.85
71710300-1	BXL-3 yük limitörlü								
71710600	BXL-6	6	1.5	9000	40	F 10	2	28.1	30.1
71710600-1	BXL-6 yük limitörlü								
71711000	BXL-10	10	1.5	10000	46	F 10	3	43	46.3
71711000-1	BXL-10 yük limitörlü								

**Ağır
Hizmet
Heavy Duty**

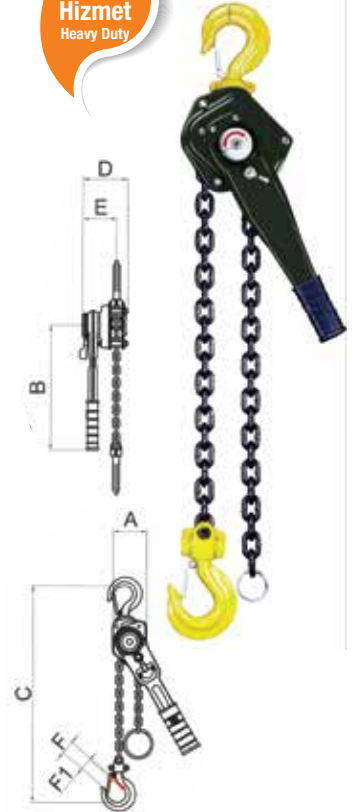

Kapasite Capacity (ton)	Boyutlar Dimensions						
	A (mm)	B (mm)	C (mm)	D (mm)	E (mm)	F (mm)	F1 (mm)
0.25	60	156	245	82	63	27	22
0.5	75	276	270	100	75	30	26
0.75	128	240	275	158	99	30	26
1	128	240	295	158	99	34	30
1.5	154	360	320	172	104	38	34
3	182	360	400	195	108	43	38
6	242	360	570	195	108	57	52

- Sağlam çelik gövde.
- Hafif, kompakt ve portatib.
- Darbelere dayanıklı.
- 360 derece dönebilen kol.
- Kullanımı kolay.
- Toz ve suya karşı tamamen korumalı.
- Tek elle kullanılabilme özelliği.
- Çift mandallı güvenli fren sistemi.
- Alışım zincir ve kanca.

- Rugged steel body construction.
- Light weight, compact and portable.
- Impact resistant.
- 360 degree handle rotation.
- Short stroke and low lever pull effort.
- Fully sealed and protect against damage from dust and water.
- Easy single-hand "Free chaining" operation.
- Safe, reliable mechanical brake system with two, brake pawls.
- High - tensile alloy chain and hooks

0.5 Ton

AYARLANABİLİR MANUEL ŞARYO / MANUEL ADJUSTABLE PLAIN TROLLEY

Kod No Code No	Model Düz Şaryo Model Plain Trolley	Kapasite Capacity (ton)	Ayarlanabilir İz Genişliği Track Widths Range 1 (mm)	Ölçüler / Dimensions (mm)										Min.Dönüş Radyusu Min. Curve Radius (m)	Net Ağırlık Net Weight (kg)
				A	A+	B	C	E	F	G	H	J	K		
71800005	BXP-0.5	0.5	62 - 128	195	235	106	106	98	20	64	10	24	30	0.8	5
71800100	BXP-1	1	62 - 128	213	253	113	113	106	20	71	10	27	34	1.0	7.5
71800200	BXP-2	2	88 - 154	236	284	136	136	132	25	80	13	38	46	1.3	12
71800300	BXP-3	3	87 - 153	270	318	146	146	150	25	97	13	42	53	1.5	19.5
71800500	BXP-5	5	106 - 194	323	371	169	169	174	30	117	16	46	59	1.5	30.5
71801000	BXP-10	10	125 - 320	346	394	237	236	210	40	117	-	-	-	1.5	135.5

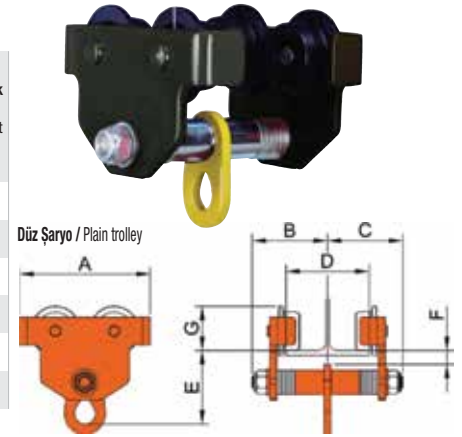

AYARLANABİLİR ZİNCİRLİ ŞARYO / MANUEL ADJUSTABLE CHAIN TROLLEY

Kod No Code No	Model Zincirli Şaryo Model Chain Trolley	Kapasite Capacity (ton)	Ayarlanabilir İz Genişliği Track Widths Range 1 (mm)	Ölçüler / Dimensions (mm)										Min.Dönüş Radyusu Min. Curve Radius (m)	Net Ağırlık Net Weight (kg)
				A	A+	B	C	E	F	G	H	J	K		
71810005	BXG-0.5	0.5	62 - 203	195	235	179	106	98	20	64	10	24	30	0.8	9
71810100	BXG-1	1	62 - 203	213	253	180	113	106	20	71	10	28	34	1.0	11
71810200	BXG-2	2	88 - 230	236	284	194	136	132	25	80	12	38	46	1.3	16.5
71810300	BXG-3	3	87 - 230	270	318	197	146	150	25	97	13	42	52	1.5	24.5
71810500	BXG-5	5	106 - 305	323	371	216	169	174	30	117	16	46	60	1.5	35.5
71811000	BXG-10	10	125 - 320	346	394	282	243	210	40	117	-	-	-	1.5	78

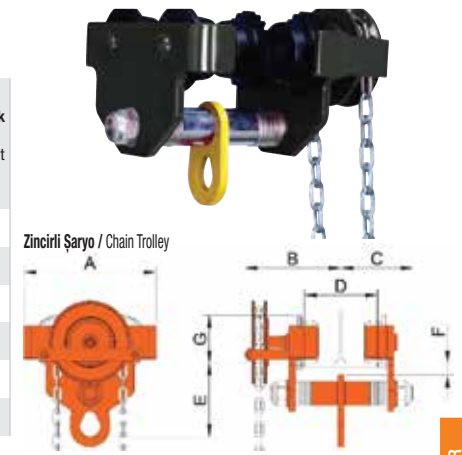

Netlift Blac Rulmanlı Şaryolar

- Netlift Blac şaryolar kolay ve düzgün hareket imkanı sağlar.
- Hem elektrikli hem manuel ceraskallar için kullanılabilir.
- Güvenlik katsayısı 5'tir.
- Rulmanlı tekerler kolay ve düzgün hareket imkanı sağlar.
- Ekstra güvenlik sağlayan dizayn sayesinde tekerler ray sonlarındaki tutuculara çarpma bile zarar görmesini engeller.

Netlif Ball Bearing Trolley

- Netlif trolleys are designed to provide smooth and easy traversing.
- The 5:1 design factor allows the Netlif trolleys to be used with both manual or powered hoists.
- The Anti-Drop plates design ensure extra safety, also prevent damage to wheels when contacting end rail stoppers.
- Wheels run on sealed ball bearings. Smoother rolling with less effort and maintenance.

RAY KISKACI / BEAM CLAMPS

	NL-BC 10	NL-BC 20	NL-BC 30	NL-BC 50		
Kapasitesi / Capacity	1000	2000	3000	5000	kg	
Kapma genişliği / Flange width	75-230	75-230	80-320	90-310	mm	
Ölçüler / Dimensions	A (Max.)	246	246	320	310	mm
	B (Min./Max.)	186/ 350	186/ 350	232/ 455	242/ 445	mm
	C	66	74	102	110	mm
	D	4	6	8	10	mm
	E	215	215	255	255	mm
	F (Max./Min.)	133/ 90	133/ 90	195/ 143	193/ 145	mm
	G (Min.)	44	44	75	75	mm
	H	20	20	22	28	mm
Ağırlık / Weight	I (Min./Max.)	14/ 21	14/ 21	30/ 34	30/ 34	mm
		4	5	9.5	11.5	kg

Art.No. 52000061	NL-BC 10
Art.No. 52000062	NL-BC 20
Art.No. 52000063	NL-BC 30
Art.No. 52000064	NL-BC 50

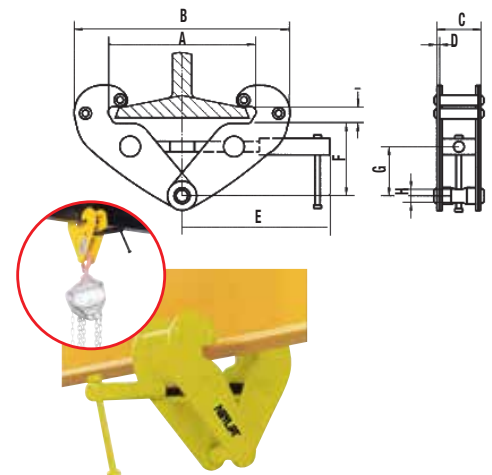

360° DÖNER CERASKAL / CHAIN HOIST

HSJ 360 1-3/2 HSJ 360 1-5/2 HSJ 360 2-3/2 HSJ 360 2-5/2 HSJ 360 3-3/2 HSJ 360 3-5/2

Kapasitesi / Capacity	1	1	2	2	3	3	ton
Kaldırma yüksekliği / Lift	3	5	3	5	3	5	m
El kuvveti / Hand force to lift load	24.49	24.49	33.56	33.56	41.73	41.73	kg
Ölçüler / Dimensions	14.93	14.93	21.64	21.64	26.51	26.51	mm
A	355.6	355.6	395	395	520	520	mm
B	22.2	22.2	30	30	38	38	mm
C	28.6	28.6	35	35	39.7	39.7	mm
D	14.3	14.3	20.6	20.6	25.4	25.4	mm
E	176	176	203	203	224	224	mm
F	155.6	155.6	182.5	182.5	220	220	mm
Ağırlık / Weight	13.9	16.9	21.6	21.6	30.6	30.6	kg

TEKNİK ÖZELLİKLER

- Her açıda ceraskal kullanımı
- Tehlikeli bölgelerde kullanımının serbest olması.
- Grade 100 (Seviye) yük zinciri – Wafios bağlantısı.
- Dövülmüş ve ısıtılmış görmüş yük kancaları.
- Çift tırnaklı fren sistemi
- Serbest fren balataları
- Dövülerek işlenmiş emniyet mandalı
- 1.5x WLL (Yük Çalışma Kapasitesi) için %100 yük testi.
- WLL'nin %400 MBL'si.
- Seri çevrim testi

KULLANIM ALANLARI

- Maden ocaklarında
- Petrol ve gas platformlarında
- Gemi inşaat sahasında
- Lojistik, orman alanlarında v.b.
- Köprü inşaatı sahasında, inşaat alanlarında v.b.
- Kaldırma, indirme, sökme ve bağlantıların sınırlı olduğu her yerde.

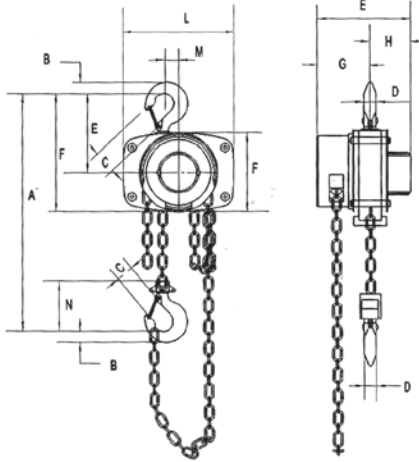

Art.No. 52000196 NL-HSJ 360 1-3/2

Art.No. 52000198 NL-HSJ 360 1-5/2

Art.No. 52000199 NL-HSJ 360 2-3/2

Art.No. 52000202 NL-HSJ 360 3-3/2

Art.No. 52000284 NL-HSJ 360 2-5/2

Art.No. 52000285 NL-HSJ 360 3-5/2

CERASKAL / CHAIN HOIST

NL-HSJ 1/4 NL-HSJ 1/2 NL-HSJ 1 NL-HSJ 2 NL-HSJ 3 NL-HSJ 5 NL-HSJ 10 NL-HSJ 20

Kaldırma kapasitesi / Capacity	1/4	1/2	1	2	3	5	10	20	ton
Standart yükseklik / Standard lift	3m/5m	3m/5m	3m/5m	3m/5m	5m	5m	5m	5m	m
Test yükü / Runnig test load	306	750	1500	3000	4500	6250	12500	25000	kg
Kapalı yükseklik / Headroom (drawn closeup) H min	230	271	400	420	620	704	720	1000	mm
Max yükte harcanan kuvvet / Effort required to life max. load	215	221	304	314	343	382	392	392	N
Zincir donam sayısı / No. of column of load chain	1	1	1	2	2	2	4	8	ad
Yük zinciri ölçüsü / Load chain dia.	4	6	6	6	8	10	10	10	mm
İlave her metre için ağırlık / Extra weight per meter of extra lift	0.4	1.7	1.7	2.5	3.7	5.3	9.7	19.4	kg
Ağırlık / Weight	3.5	9	11	15	24	39	72	160	kg

- Galvaniz zincir • Galvanized chain



Art.No. 52000010 NL-HSJ 1/4-3

Art.No. 52000011 NL-HSJ 1/4-5

Art.No. 52000012 NL-HSJ 1/2-3

Art.No. 52000013 NL-HSJ 1/2-5

Art.No. 52000014 NL-HSJ 1-3

Art.No. 52000015 NL-HSJ 1-5

Art.No. 52000016 NL-HSJ 2-3

Art.No. 52000017 NL-HSJ 2-5

Art.No. 52000018 NL-HSJ 3-5

Art.No. 52000019 NL-HSJ 5-5

Art.No. 52000020 NL-HSJ 10-5

Art.No. 52000021 NL-HSJ 20-5

ZİNCİRLİ ÇEKTİRME / LEVER HOIST

	HSH-D 1/2	HSH-D 1/4	HSH-D 3/4	HSH-D 1	HSH-D 1.5	HSH-D 3	HSH-D 6	HSH-D 9	
Kaldırma kapasitesi / Capacity	1/2	1/4	3/4	1	1.5	3	6	9	t
Çektirme mesafesi / Pulling distance	1	1	1.5	1.5	1.5	1.5	1.5	1.5	m
Test yükü / Running test load	375	375	1125	1.5	2250	4500	7500	11200	kg
Kapalı yükseklik / Headroom (drawn closeup) H min	230	230	325	340	380	480	620	700	mm
Max yükte harcanan kuvvet / Effort required to life max. load	250	250	140	187	220	320	340	360	N
Zincir donam sayısı / No. of column of load chain	1	1	1	1	1	1	2	3	ad
Yük zinciri ölçüsü / Load chain dia.	4	4	6	6	8	10	10	10	mm
İlave her metre için ağırlık / Extra weight per meter of extra lift	0.4	0.4	0.8	0.8	1.4	2.2	4.4	6.6	kg
Ağırlık / Weight	1.8	1.8	7	7.2	11	21	31	47	kg

• Galvaniz zincir • Galvanized chain



Art.No. 52000029	NL-HSH-D 1/2
Art.No. 52000022	NL-HSH-D 1/4
Art.No. 52000023	NL-HSH-D 3/4
Art.No. 52000024	NL-HSH-D 1
Art.No. 52000025	NL-HSH-D 1.5
Art.No. 52000026	NL-HSH-D 3
Art.No. 52000027	NL-HSH-D 6
Art.No. 52000028	NL-HSH-D 9

ZİNCİRLİ ŞARYO / GEARED TROLLEY

	NL-GT 0.5	NL-GT 1	NL-GT 2	NL-GT 3	NL-GT 5	NL-GT 10	NL-GT 20		
Kapasitesi / Capacity	0.5	1	2	3	5	10	20	t	
Çalışma yüksekliği / Running height	2.5	2.5	2.5	3	3	3	3	m	
Test yükü / Test load	7.35	14.71	29.42	44.13	61.29	122.58	245.7	kN	
Min. radyus açısı / Min. radius of curveve	0.8	0.9	1.0	1.2	1.3	2.0	3.5	m	
Harcanan güç / Chain pull to lift full load	25	50	90	96	140	240	240	N	
Ölçüler / Dimensions	A	272	336	350	358	373	52	98	mm
	B	194	236	268	322	362	424	555	mm
	C	176	208	247	295	342	396	498	mm
	H	95	111	134	157	185	190	233	mm
	F	1.5-3	1.5-3	1.5-3	2-3.5	2-3.5	2-3.5	2-3.5	mm
	S _≥	28	28	30	32	36	40	45	mm
Putrel ölçüsü / I-beam commended	50-152	64-203	88-203	100-203	114-203	124-230	136-305	mm	
Ağırlık / Weight	9	13	18	29	42	94	174	kg	

Art.No. 52000048	NL-GT 0.5
Art.No. 52000049	NL-GT 1
Art.No. 52000050	NL-GT 2
Art.No. 52000051	NL-GT 3
Art.No. 52000052	NL-GT 5
Art.No. 52000053	NL-GT 10
Art.No. 52000054	NL-GT 20

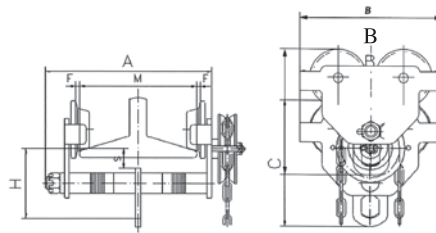

ŞARYO / MANUEL TROLLEY

	NL-PT 0.5	NL-PT 1	NL-PT 2	NL-PT 3	NL-PT 5		
Kapasitesi / Capacity	0.5	1	2	3	5	t	
Test yükü / Test load	7.35	14.71	29.42	44.13	61.29	kN	
Min. radyus açısı / Min. radius of curve	0.8	0.9	1.0	1.2	1.3	m	
Ölçüler / Dimensions	A	240	310	325	345	360	mm
	B	194	236	268	322	362	mm
	C	176	208	247	295	342	mm
	H	95	111	134	157	185	mm
	F	1.5-3	1.5-3	1.5-3	2-3.5	2-3.5	mm
	S _≥	28	28	30	32	36	mm
Putrel ölçüsü / I-beam commended	50-203	60-203	88-203	100-203	114-203	mm	
Ağırlık / Weight	5.5	9.5	14.5	24.5	37.4	kg	



Art.No. 52000055	NL-PT 0.5
Art.No. 52000056	NL-PT 1
Art.No. 52000057	NL-PT 2
Art.No. 52000058	NL-PT 3
Art.No. 52000059	NL-PT 5

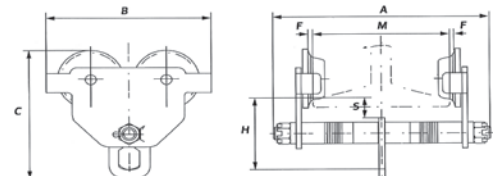

ELEKTRİKLİ HALATLI İRGAT / ELECTRIC WIRE WINCH

Kullanım Alanları:

Farklı inşaat alanları, fabrikalar, depolar, santraller, enerji tesisleri, barajlar, ziraat ve balıkçılık sektöründe, marketler, tesisat işlerinde güvenle kullanabileceğiniz yardımcınız.

Özellikleri:

Isıl işlem görmüş aşınmayan dişliler sayesinde üstün performans, kompakt ve hafif, sessiz ve uzun ömürlü, sağlam gövde ve dişli sistemi, uzun ömürlü ağır hizmet rulmanlar, statik ve dinamik yükler için dizayn edilmiş fren sistemi, güç kaybında devreye giren otomatik fren sistemi, geniş sürtünme alanı, kullanıma hazır endüksiyon motor.



Kod No Code No	Model	Kapasite Capacity (kg)	Güç Kaynağı (Voltaj/ Voltage) Power Supply (Voltaj/ Voltage) (V)	Faz Phase	Çelik Halat Çapı Wire Rope Dia. (mm)	Çelik Halat Uzunluğu Wire Rope Length (m)	Hız Speed (m / dk)	Motor Gücü Motor Power (kw)	Net Ağırlık Net Weight (kg)	Brüt Ağırlık Gross Weight (kg)
							50 Hz			
71600221	NX-221H	250	220	1	7	30	33	1.5	41	45
71600208	NX-208	350	220	1	7	30	15	1.5	42	43
71600223	NX-223H	350	220	1	7	30	38	2	66	71
71600210	NX-210	500	220	1	8	45	21	2	70	76
71601212	NX-212	1000	380	3	10	45	12	3	133	145
71602000	NX-2K	2000	380	3	12	45	12	5	183	171
71602213	NX-213	2000	380	3	12	80	12	5	364	392
71603000	NX-3K	3000	380	3	14	45	12	7.5	205	193
71603214	NX-214	3000	380	3	14	80	12	7.5	375	405
71605215	NX-215	5000	380	3	16	80	12	10	395	426

Ölçüler/ Dimensions

Kapasite Capacity (kg)	L (mm)	W (mm)	H (mm)
250	585	201	233
350	585	201	233
350	675	220	283
500	710	310	285
1000	1120	385	340
2000	1190	400	365
2000	1290	590	520
3000	1240	400	365
3000	1350	590	520
5000	1450	590	520

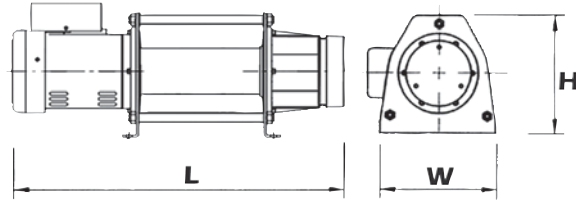

Usage:

Fit for various construction workplaces, civil engineering, general factories, plumbing, coating, scaffolding, warehousing, buildings, domestics, farming and fishing industries, stroes and even more.

Features:

Driving gear the heat treated gear with bearings features durable performance and anti-wear. Planetary and anti-wear gears. Compact and load sharing inimiz size, weight and cost. Full depth spur gear planetary reductions ensure quiet and long life. Gear box provides strength, durability and non-worry of breakage of structure. Ball bearings High efficient and heavy duty berings provide long life. Brake Designed for both static and dynamic loading. Brake will automatically apply in the event of power loss. Large friction surface area.



ELEKTRİKLİ HALATLI İRGAT / ELECTRIC WIRE WINCH

Kullanım Alanları:

Farklı inşaat alanları, fabrikalar, depolar, santraller, enerji tesisleri, barajlar, ziraat ve balıkçılık sektöründe, marketler, tesisat işlerinde güvenle kullanabileceğiniz yardımcımız.

Özellikleri:

Kaldırma ve çekme işlemlerinde özellikle ağır hizmet uygulamalarında yüksek çalıştırma torkuna sahip bir üründür. Isıl işlem görmüş aşınmayan dişliler sayesinde üstün performans, kompakt ve hafif, sessiz ve uzun ömürlü, sağlam gövde ve dişli sistemi, uzun ömürlü ağır hizmet rulmanlar.



Kod No Code No	Model	Kapasite Capacity (kg)	Güç Kaynağı (Voltaj/ Voltage) Power Supply (Voltaj/ Voltage) (V)	Faz Phase	Çelik Halat Çapı Wire Rope Dia. (mm)	Çelik Halat Uzunluğu Wire Rope Length (m)	Hız Speed (m / dk)	Motor Gücü Motor Power (kw)	Net Ağırlık Net Weight (kg)
							50 Hz		
71600001	AMW-1000	1000	380	3	11	60	13-19	3	160
71600002	AMW-1600	1600	380	3	13	100	13-19	4	185
71600003	AMW-3200	3200	380	3	18	45	8-14	7.5	440

ÇOK AMAÇLI AKÜLÜ İRGAT / MULTIPURPOSE ELECTRIC PULLER

NL-A100

Yuvarlama kapasitesi / Rolling capacity	2722/6000	kg/ lbs
Marine kapasitesi / Marine capacity	2268/5000	kg/ lbs
Çekme kapasitesi / Pulling capacity	907/2000	kg/ lbs
Hız(yüklü) / Line speed (with load)	1.8	m/min
Halat (çap / uzunluk) Wire rope (Dia x L)	5.1mm x 9m	mm/m
Güç kablosu / Power cord	4.5mm / 3m	mm/m
Motor / Motor	0.4	hp
Çalışma voltajı / Voltage	12	V/DC
Ölçüler / Dimensions	240x254x190	mm
Ağırlık / Weight	13	kg

*Montaj plakası ve krank mili dahildir. / Mounting plate and hand crank included.

Art.No. 59000093

NL-A100



ÇOK AMAÇLI AKÜLÜ İRGAT / MULTIPURPOSE ELECTRIC PULLER

NL-A101

Yuvarlama kapasitesi / Rolling capacity	4082/9000	kg/ lbs
Marine kapasitesi / Marine capacity	3175/7000	kg/ lbs
Çekme kapasitesi / Pulling capacity	1365/3000	kg/ lbs
Hız(yüklü) / Line speed (with load)	1.8	m/min
Halat (çap / uzunluk) Wire rope (Dia x L)	5.6mm x 9m	mm/m
Güç kablosu / Power cord	4.5mm / 3m	mm/m
Motor / Motor	0.6	hp
Çalışma voltajı / Voltage	12	V/DC
Ölçüler / Dimensions	260x305x193	mm
Ağırlık / Weight	15.7	kg

*Montaj plakası ve krank mili dahildir. / Mounting plate and hand crank included.

Art.No. 59000094

NL-A101



AKÜLÜ İRGAT / ELECTRIC PULLER

NL-A094

Art.No. 59000090

NL-A094

Kapasite / Capacity	909kg / 2000 lbs
Motor / Motor	12V 1.1 HP
Halat (çap/uzunluk) / Cable (Dia. x L)	4.8 mm x 7.6 m
Makara(çap/uzunluk) / Drum size (Dia. x L)	32 mm x 73 mm
Montaj civatası / Mounting bolt pattern	80mm 2-M8

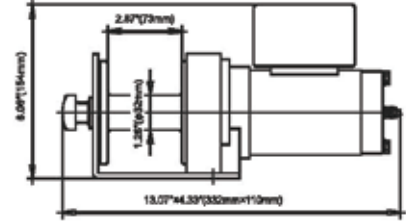

Makaralı halat çekme kapasitesi Line pull and rope capacity inlayer			Hız ve voltaj akımı Speed and Volts		
Kat Layer	Çekme gücü Ratel line pull (kg/lbs)	Makaralı halat Total rope on drum ft(m)	Çekme kolu Line pull Kg / Lbs	Hız / Line speed Ft / min (m/min)	Akım Current A
1	909 (2000)	5.5 (1.68)	0	14 (4.26)	8
2	721 (1586)	12.43 (3.79)	454 (1000)	10 (3.05)	35
3	597 (1314)	20.8 (6.34)	682 (1500)	8 (2.44)	58
4	509 (1121)	25 (7.6)	909 (2000)	4 (1.22)	85

AKÜLÜ İRGAT / ELECTRIC PULLER

NL-A096

Art.No. 59000091

NL-A096

Kapasite / Capacity	2045g / 4500 lbs
Motor / Motor	12V 2.0 HP
Halat (çap/uzunluk) / Cable (Dia. x L)	6 mm x 12 m
Makara(çap/uzunluk) / Drum size (Dia. x L)	55 mm x 75 mm
Montaj civatası / Mounting bolt pattern	123x76mm 4-M8

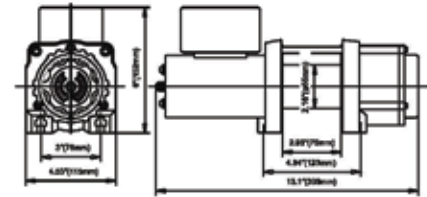

Makaralı halat çekme kapasitesi Line pull and rope capacity inlayer			Hız ve voltaj akımı Speed and Volts		
Kat Layer	Çekme gücü Ratel line pull (kg/lbs)	Makaralı halat Total rope on drum ft(m)	Çekme kolu Line pull Kg / Lbs	Hız / Line speed Ft / min (m/min)	Akım Current A
1	2045 (4500)	7.87 (2.4)	0	16 (4.88)	17
2	1726 (3798)	17.26 (5.26)	227 (500)	12.5(3.81)	50
3	1493 (3285)	28.2 (8.59)	909 (2000)	9.6(2.92)	130
4	1316 (2895)	39 (12)	2045 (4500)	3 (0.914)	245

AKÜLÜ İRGAT / ELECTRIC PULLER

NL-A097

Art.No. 59000092

NL-A097

Kapasite / Capacity	4545g / 10000 lbs
Motor / Motor	12V 6 HP
Halat (çap/uzunluk) / Cable (Dia. x L)	6 mm x 12 m
Makara(çap/uzunluk) / Drum size (Dia. x L)	9.2 mm x 28 m
Montaj civatası / Mounting bolt pattern	254x114mm 4-M10

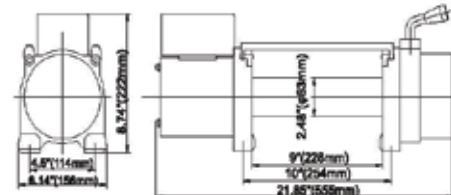

Makaralı halat çekme kapasitesi Line pull and rope capacity inlayer			Hız ve voltaj akımı Speed and Volts		
Kat Layer	Çekme gücü Ratel line pull (kg/lbs)	Makaralı halat Total rope on drum ft(m)	Çekme kolu Line pull Kg / Lbs	Hız / Line speed Ft / min (m/min)	Akım Current A
1	4545 (10000)	18 (5.5)	0	19.45 (5.93)	50
2	3622 (7969)	41 (12.5)	1363 (3000)	17.45 (5.32)	150
3	3010 (6623)	68.5 (20.9)	2727 (6000)	15.45 (4.71)	200
4	2576 (5667)	92 (28)	3636 (8000)	12.46 (3.8)	270
5			4545 (10000)	10.5 (3.2)	320

ELEKTRİKLİ MİNİ VİNÇ / MINI WIRE ROPE HOIST

NL-EW 100-200

Kaldırma kapasitesi / Capacity (Tek-Çift hat) / (Single-Double Line)	100/ 200	kg
Kaldırma yüksekliği / Lifting height (Tek-Çift hat) / (Single-Double Line)	25/ 11,5	m
Koruma sınıfı / Protection class	IP54	
Kaldırma hızı / Lifting speed (Tek-Çift hat) / (Single-Double Line)/	10/ 5	m/ dk
Halat uzunluğu / Wire rope length	25	m
Halat çapı / Wire rope diameter	3	mm
Motor gücü / Motor power	500	W
Voltaj / Power source (Tek-Çift hat) / (Single-Double Line)	230/ 50	V/Hz

Art.No. 52500042

NL-EW 100-200



ELEKTRİKLİ MİNİ VİNÇ / MINI WIRE ROPE HOIST

NL-EW 125/250

NL-EW 250/500

Kaldırma kapasitesi / Capacity (Tek-Çift hat) / (Single-Double Line)	125/ 250	250/ 500	kg
Kaldırma yüksekliği / Lifting height (Tek-Çift hat) / (Single-Double Line)	11/ 5.5	12/ 6	m
Koruma sınıfı / Protection class	IP54	IP54	
Kaldırma hızı / Lifting speed (Tek-Çift hat) / (Single-Double Line)	10/ 5	10/ 5	m/ dk
Halat uzunluğu / Wire rope length	12	12	m
Halat çapı / Wire rope diameter	3	4	mm
Motor gücü / Motor power	580	930	W
Voltaj / Power source (Tek-Çift hat) / (Single-Double Line)	230/ 50	230/ 50	V/Hz

Art.No. 52500040

NL-EW 125/250

Art.No. 52500041

NL-EW 250/500



- Limit şalteri • Limit switch
- Acil stop butonu • Emergency stop button

ELEKTRİKLİ MİNİ VİNÇ / MINI WIRE ROPE HOIST

NL-EW 200-400

NL-EW 500-1000

Kaldırma kapasitesi / Capacity (Tek-Çift hat) / (Single-Double Line)	200 - 400	500 - 1000	kg
Kaldırma yüksekliği / Lifting height (Tek-Çift hat) / (Single-Double Line)	25/11.5	12/6	m
Koruma sınıfı / Protection class	IP 54	IP 54	
Kaldırma hızı / Lifting speed (Tek-Çift hat) / (Single-Double Line)/	10/ 5	10/ 5	m/ dk
Halat uzunluğu / Wire rope length	12	12	m
Halat çapı / Wire rope diameter	3.6	6	mm
Motor gücü / Motor power	1050	1650	W
Voltaj / Power source (Tek-Çift hat) / (Single-Double Line)	230/ 50	230/ 50	V/Hz

Art.No. 52500043

NL-EW 200-400

Art.No. 52500044

NL-EW 500-1000



MİNİ VİNÇ AYAĞI / WINCH SUSPENSION SYSTEM

NL-WT 250-1100

NL-WT 300-750

Kapasite/ Rated lifting	250	600	kg
Maks. uzatma boyu / Max extension length	1200	750	mm
Brüt ağırlık / Gross weight	30	38	kg
Net ağırlık / Net weight	28	36	kg

Art.No. 52500045

NL-WT 300-750

Art.No. 52500046

NL-WT 250-1100

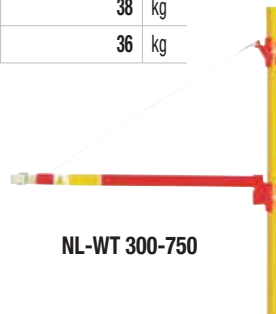

NL-WT 300-750

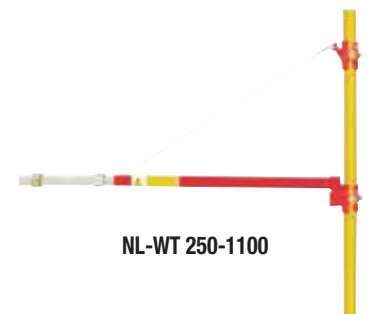

NL-WT 250-1100

HALATLI ÇEKTİRME Alüminyum Gövdeli / ALUMINIUM HOUSING PULLING HOIST

	NL-HX 800A	NL-HX 1600A	NL-HX 3200A	
Kapasitesi / Capacity	800	1600	3200	kg
Halat çapı / Rope diameter	8.3	11	16	mm
Ölçülen ileri el hareket gücü / Rated forward handpower	343	441	441	N
Ölçülen ileri hareket / Rated forward travel	≥52	≥55	≥28	mm
Test yükü / Proof test load	1200	2400	4000	kg
Çelik halat emniyet faktörü ve yük kapasitesi/ Wire rope safety factor and load capacity/	5	5	5	
Emniyet faktörü/ Statik yük kapasitesi/ Safety factor and static load capacity	5	5	5	
Ölçüler / Dimensions	A	426	545	660
	B	235	280	325
	C	168	190	230
	L1		800	800
	L2	800	1200	1200
Ağırlık / Weight	6	11	22	kg

- Hafif, küçük ve sağlam alüminyum gövde
- Ön koldaki pim mekanizması ile sağlanan aşırı yük koruma sistemi. Taşıma kolunda veya operasyon levyesinde yedek makas pimleri
- Çelik halatın kolayca monte edilmesini sağlayan mekanizma
- Birim harekette uzun halat hareketi
- Test edilmiş %150 aşırı yük testlidir
- Üstte rahat temizliği kolaylaştıran geniş açıklık
- Makine Emniyet Yönetmeliği 2006/42 EC'ye uygun üretilmiştir.
- Özel siparişlerde çelik halat seti ile teslim
- Standart çelik halat uzunluğu 20 ve 30 metredir.

- Light weight, compact, high strength aluminium housing
- Overload protection is by a sharing pin in the forward lever. Spare shear pins are conveniently located in the carrying handle or operating lever
- Easy, smooth installation of the wire rope
- Long rope advance per each lever stroke
- 150% overload factory tested
- Large opening in the top of the unit for cleaning
- Manufactured according to machinery directive 2006/42
- Can be supplied with wire rope set to special order
- The standard wire rope lengths are 20 and 30 metres.

Halat uzunluğu/ Rope length:

20m Art.No. 52000090

30m Art.No. 52000091

NL-HX 800 A

Art.No. 52000092

Art.No. 52000093

NL-HX 1600 A

Art.No. 52000094

Art.No. 52000095

NL-HX 3200 A

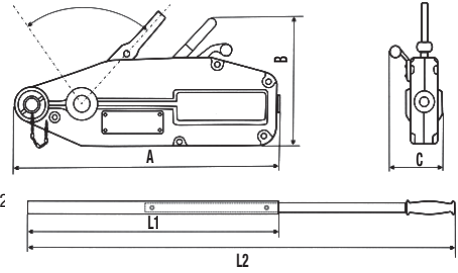

HALATLI ÇEKTİRME Çelik Gövdeli / IRON HOUSING PULLING HOIST

	NL-HX 800S	NL-HX 1600S	NL-HX 3200S	
Kapasitesi / Capacity	800	1600	3200	kg
Halat çapı / Rope diameter	8.3	11	16	mm
Ölçülen ileri el hareket gücü / Rated forward handpower	343	441	441	N
Ölçülen ileri hareket / Rated forward travel	≥52	≥55	≥28	mm
Test yükü / Proof test load	1200	2400	4000	kg
Çelik halat emniyet faktörü ve yük kapasitesi/ Wire rope safety factor and load capacity/	5	5	5	
Emniyet faktörü/ Statik yük kapasitesi/ Safety factor and static load capacity	5	5	5	
Ölçüler / Dimensions	A	440	550	690
	B	265	300	350
	C	63	77	91
	L1		800	800
	L2	800	1200	1200
Ağırlık / Weight	18	30	56	kg

Halat uzunluğu/ Rope length:

20m Art.No. 52000096

30m Art.No. 52000097

NL-HX 800 S

Art.No. 52000098

Art.No. 52000099

NL-HX 1600 S

Art.No. 52000100

Art.No. 52000101

NL-HX 3200 S

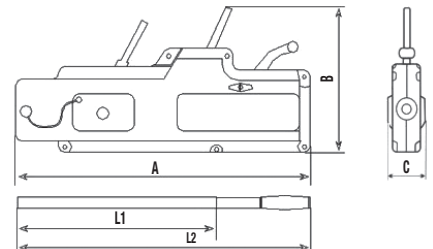

HALATLI ÇEKTİRME Alüminyum Gövdeli / ALUMINUM HOUSING PULLING HOIST

NL-HX 5400A

Halat uzunluğu/ Rope length:

20m 30m

Art.No. 52000102

Art.No. 52001002

NL-HX 5400 A

Kapasitesi / Capacity		5400	kg
Halat çapı / Rope diameter		20	mm
Ölçülen ileri el hareket gücü		745	N
Ölçülen ileri hareket /Rated forward travel		≥30	mm
Test yükü / Proof test load		8000	kg
Çelik halat emniyet faktörü ve yük kapasitesi/ Wire rope safety factor and load capacity		5	mm
Emniyet faktörü/ Statik yük kapasitesi/ Safety factor and static load capacity		5	mm
Ölçüler / Dimensions	A	932	mm
	B	420	mm
	C	300	mm
	L1	880	mm
	L2	1360	mm

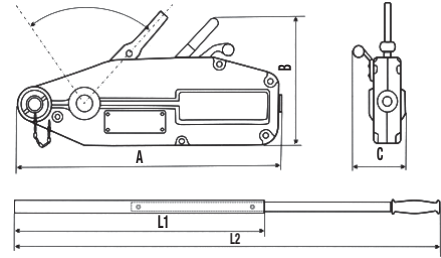
**HALATLI ÇEKTİRME / HAND POWER PULLER**

NL-HP 147 D

Kapasite/ Capacity	4000	kg
Halat ölçüleri / Cable	6 x 3000	mm
Kanca sayısı / Hook	3	
Et kalınlığı (kol) / Thickness handle	5	mm
Et kalınlığı (gövde) / Thickness body	6	mm
Ağırlık / Weight	7.3	kg

Art.No. 52000116

NL-HP 147 D

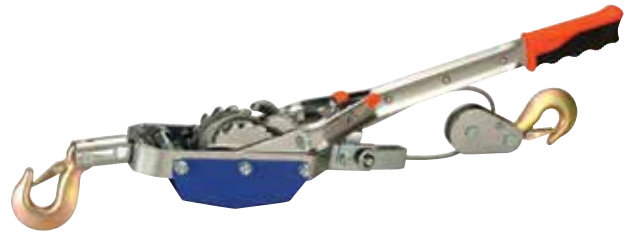
**POLYESTER BANTLI ÇEKTİRME / WEB-STRAP PULLER**

NL-WS 10

NL-WS 15

Kapasite / Capacity	1000	1500	kg
Bant ölçüsü / Strap dimension	2 x 33	2.2 x 40	mm
Kol uzunluğu / Lever length	400	460	mm
Maks. uzunluk / Max. length	1280	1320	mm
Min. uzunluk / Min. length	420	450	mm
Ağırlık / Weight	3.2	4.5	kg

Art.No. 52000118

NL-WS 10

Art.No. 52000119

NL-WS 15

**ELEKTRİKLİ VİNÇ-IRGAT / ELECTRIC ROPE PULLER**

EWP 250-15

EWP 500-15

EWP 500-30

Çekme gücü / Pulling force in the upper layer	250	500	500	kg
Kaldırma hızı / Lifting speed	15	15	30	m/min
Çelik halat / Wire rope	5	6	6	mm
Motor gücü / Motor performance	0.55	1.1	2.2	kw
Standart halat boyu / Standart rope length	60	60	60	m
Halatsız ağırlık / Weight without rope	55	90	96	kg
Voltaj / Voltage		380		V

Art.No. 52500067

NL-EWP 250-15

Art.No. 52500069

NL-EWP 500-15

Art.No. 52500070

NL-EWP 500-30



Her vinç aşırı yükte test edilmiştir. DIN15020'ye, VBG8 (vinç, kaldırma, çekme ekipmanları) güvenlik tüzüğüne ve EC makine direktiflerine uyumludur. Az yer kaplayan ölçüleri iç fren motoruna uygundur. Standart: Euro-Voltaj 230/400V, 50Hz 3 faz, Koruma sınıfı IP 54, izolasyon sınıfı F. Tetikleyici dişli güç aktarım sistemi sayesinde düzgün hareket sağlar. Yağlanarak kolay işler hale getirilir. Motorun içine dahil edilmiş olan fren diski elektrik kesildiğinde bile yükü güvenli bir şekilde tutar. Düz halat tambur standardındadır. Halat sonu tambura sabitlendiği için zarar görmeden defalarca sarılıp açılabilir. Direk kontrol standarttır.

Every winch is factory tested with overload. In accordance with DIN15020, safety regulation VBG8 (winch, lift and pull equipment) and the EC machinery directives. Compact dimensions due to internal brake motor. Standard: Euro-voltage 230/400V, 50Hz, 3-phase, protected to IP 54, Insulation class F. Spur gear transmission with helical first gear ensures smooth motion. Lubricated by grease and can, therefore, be used in any position. Spring pressure disc brake incorporated in the motor holds the load secure even in the event of power failure. Plain rope drum standard. The rope is secured to the drum in a recess so that the rope can be wound onto the drum in several layers without damage. Direct control as standard.

EMNİYETLİ MANUEL İRGAT / BRAKE WINCH

	NL-BHW 800	NL-BHW 1200	NL-BHW 1800	NL-BHW 2600
Kapasite / Capacity	360	550	800	1180
Gerekli el kuvveti / Required hand force	20	14	22	10
Dışli oranı / Gear ratio	4.1 : 1	4.1 : 1	5 : 1	10 : 1
Irgat göbek çapı / Hub diameter	40	50	70	80
Kol uzunluğu / Handle length	160	210	320	320
Halat çapı / Cable diameter	4	4.8	6.4	8
Kablo muhafaza kapasitesi / Cable storage cap.	36	23	24	18
Birim ağırlığı / Unit weight	3	3.3	8	10.3

Art.No. 52000190	NL-BHW 800
Art.No. 52000127	NL-BHW 1200
Art.No. 52000128	NL-BHW 1800
Art.No. 52000191	NL-BHW 2600
Art.No. 52000192	NL-BHW 800 PLUS
Art.No. 52000193	NL-BHW 1200 PLUS
Art.No. 52000194	NL-BHW 1800 PLUS
Art.No. 52000195	NL-BHW 2600 PLUS

- Kompakt, hafif ve sağlam ürün yapısına sahiptir.
- Dişliler ve fren mekanizması, toz, kir ve yağmur atıklarından korumayı sağlamak üzere kapalı sistem tasarlanmıştır.
- Operatör ürünü kullanırken çok az enerji sarf eder.
- Üniversal montaj plakasına sahiptir.
- Renkli fırınlanmış emaye kaplama sayesinde korozyon dayanımını artırılmıştır.

- Positive load, actuated brake can hold the load in any position
- Compact, light-weight and rugged construction
- Gears and brake are fully covered to prevent dust, dirt and rain contamination
- Very low operator effort is required for easy operation
- Universal mounting base
- Baked yellow enamel paint finish for corrosion protection



NL- BHW 2600

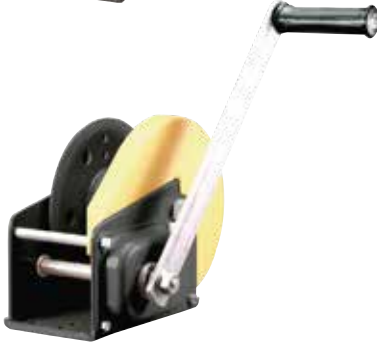
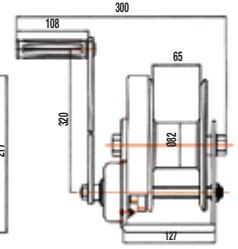
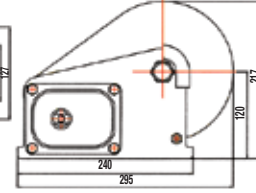
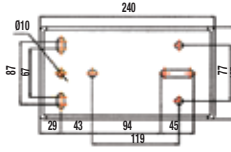

NL- BHW 1800

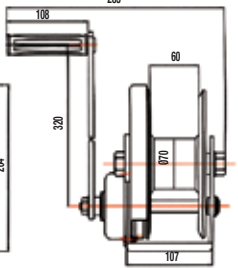
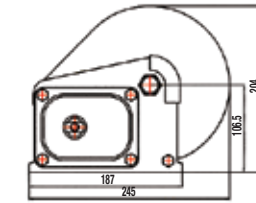
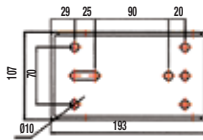

NL- BHW 1200

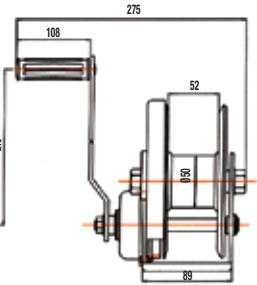
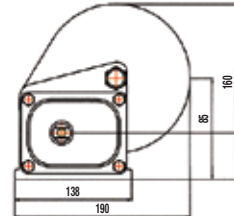
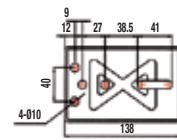

NL- BHW 800

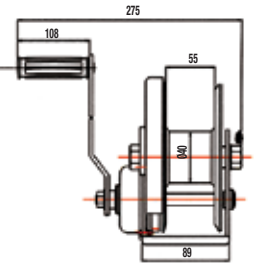
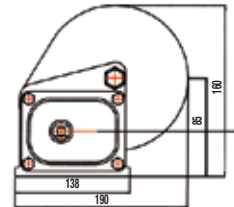
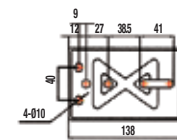

POLYESTER HALATLI İRGAT / BRAKE WINCH WITH WEBBING

	BHW 800W	BHW 1200W	BHW 1800W	BHW 2600W	
Kapasite / Capacity	360	550	800	1180	kg
Gerekli el kuvveti / Required hand force	20	14	22	10	kg
Dışli oranı / Gear ratio	4.1 : 1	4.1 : 1	5: 1	10: 1	
İrgat göbek çapı / Hub diameter	40	50	70	80	mm
Kol uzunluğu / Handle length	160	210	320	320	mm
Birim ağırlığı / Unit weight	3	3.3	8	10.3	kg
Polyester bant uzunluğu / Length of polyester	6	6	6	6	m

Art.No. 52000208

NL-BHW 800W

Art.No. 52000209

NL-BHW 1200W

Art.No. 52000214

NL-BHW 1800W

Art.No. 52000219

NL-BHW 2600W



KABLO ÇEKTİRME APARATI (mini) / WIRE GRIP (mini)

NL-WG 05G

Kapasite / Capacity	500	kg
Min. kablo çapı / Min. cable dia.	1	mm
Max. kablo çapı / Max. cable dia.	10	mm
Ağırlık / Weight	0.4	kg

- Bakır kaplı, kılavuz kabloları, dikenli tel ve kılavuz telleri çekmede kullanılır.
- Used for copper cable, covered conductor, steel rod, messenger wire and barbed wire.

Art.No. 52000122

NL-WG 05G



KABLO ÇEKTİRME APARATI / WIRE GRIP

NL-WG SDL 10C

Kapasite / Capacity	500	kg
Min. kablo çapı / Min. cable dia.	2.6	mm
Max. kablo çapı / Max. cable dia.	15	mm
Ağırlık / Weight	0.75	kg

- Bakır kaplı, kılavuz kabloları, dikenli tel ve kılavuz telleri çekmede kullanılır.
- Used for copper cable, covered conductor, steel rod, messenger wire and barbed wire.

Art.No. 52000124

NL-WG SDL 10C



KABLO ÇEKTİRME APARATI / WIRE GRIP

NL-WG 30MCL

Kapasite / Capacity	3000	kg
Min. kablo çapı / Min. cable dia.	8	mm
Max. kablo çapı / Max. cable dia.	25	mm
Ağırlık / Weight	2.2	kg

- Bakır kaplı, kılavuz kabloları ve kılavuz telleri çekmede kullanılır.
- Used for copper cable, covered conductor, messenger wire and barbed wire.

263 \$

Art.No. 52000125

NL-WG 30MCL



KABLO ÇEKTİRME APARATI / WIRE GRIP

NL-WG 1656-20

Kapasite / Capacity	2000	kg
Min. kablo çapı / Min. cable dia.	5	mm
Max. kablo çapı / Max. cable dia.	10	mm
Çene uzunluğu / Jaw length	105	mm
Ağırlık / Weight	1.36	kg

- Alüminyum ve bakır kablolar için uygundur.
- Tutma yüzeyinin büyüklüğü kabloya az zarar verilmesini önler.
- Used for bare A.C.S.R. aluminium and stranded-copper cable.
- Maximum contact; less damage for conductors.

Art.No. 52000126

NL-WG 1656-20





NET MAK
METAL MAKİNA SANAYİ VE TİCARET LTD. ŞTİ.

200 TON'a kadar olan YÜKLERİNİZİ TAŞIR!

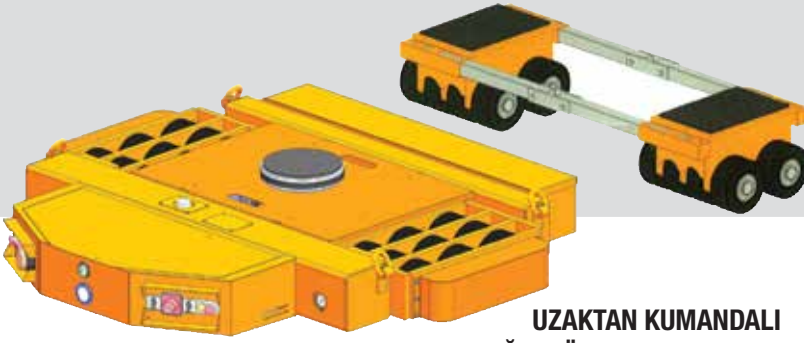

**UZAKTAN KUMANDALI
AĞIR YÜK TAŞIMA ARABALARI**

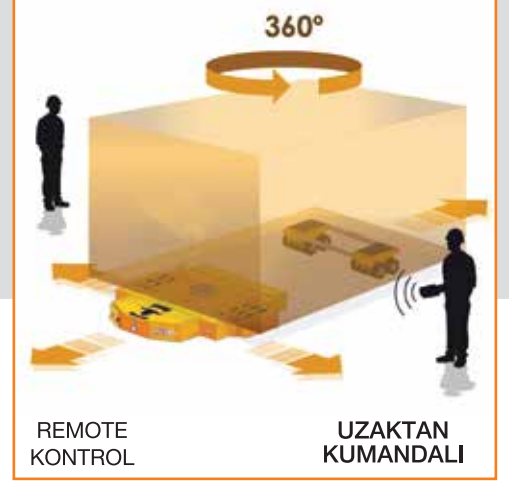

REMOTE
KONTROL

UZAKTAN
KUMANDALI



HİDROLİK KRİKOLAR
HYDRAULIC JACKS

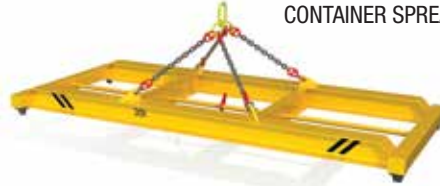

**KONTEYNER
TRAVERS**
CONTAINER SPREADER



ÖZEL TRAVERSLER
SPECIAL BEAMS



YÜK ARABALARI
TROLLEYS



H TİPİ TRAVERSLER
H TYPE BEAMS



**MOTORLU
TRAVERSLER**
ROTATING BEAMS



**MOTORLU RULO
TAŞIMA ARABASI**
MOTORIZED
TROLLEYS FOR REELS



**ALÜMİNYUM
TAŞINABİLİR
TRAVERSLER**
ALUMINIUM PORTABLE
GANTRIES



**MİKNATISLI
TRAVERSLER**
MAGNET BEAMS



**ÇİFT KOLLU
C KANCALAR**
DOUBLE
C TYPE HOOKS

**ELEKTRONİK
KANCALI VİNÇ**
ELECTRONIC
HOOK BLOCK
WEIGHT CRANE



C KANCALAR
C TYPE HOOKS