

NETLIFT®

60nm.yel



ÜRÜN KATALOĞU

PRODUCT CATALOGUE



SATIŞ SONRASI HİZMETLER

Netlift ve Netmak markalı taşıma ve kaldırma ekipmanlarınıza en iyi bakımı biz yaparız! Türkiye genelinde yaygın servis ağı ve gezici servis araçlarımız sayesinde müşterilerimiz bakım ve onarım hizmetlerimizden kolay ve hızlı bir şekilde faydalanabilmektedir.



SEVKİYAT

Ürün sevkiyatlarında kendi lojistik araçlarımız ve bölgesine göre diğer nakliye araçları ile hizmet verilmektedir.



TEST LABORATUVARI

Laboratuvarımızda bulunan kalibrasyonlu 200t kapasiteli yatay test makinesinde çekme, yorma, kopartma ve tutma testleri yapılmakta 1000t kapasiteli dikey test makinesinde basma ve sızdırmazlık testleri yapılmaktadır.

EĞİTİMLER

Doğru taşıma, kaldırma, istifleme ekipmanı seçilmesi, ekipmanların doğru kullanılması, uygulanması gereken periyodik kontroller vb. konularda eğitim desteği verilmekte, ihtiyaç durumunda saha tespit çalışmaları yapılmaktadır.





Türk Makine Sektörü 50. Yıl Onur Ödülü

SERTİFİKALAR

Mevzuatların gerektirdiği deklarasyonlar, CE uygunluk belgeleri, yürürlükteki güncel ürün standartlarına uygun test raporları, kalite belgeleri, satış sonrası hizmet yeterlilik belgeleri mevcuttur.



LOJİSTİK

Sakarya 2.OSB içinde 20.000m2 alan üzerine kurulu tesislerimizde raflı ve raflısız depolama alanlarımız bulunmakta olup kalifiye lojistik ve kalite kontrol hizmetlerimiz sayesinde her ürün detaylı bir şekilde kontrolden geçirilir ve muhafaza edilir.



TRANSPALETLER Pallet Trucks

4 - 28



İSTİF MAKİNELERİ Stackers

29 - 58



PLATFORMLAR Table Trucks

59 - 67



PERSONEL YÜKSELTİCİLER Aerial Work Platforms

69 - 81



FORKLİFTLER Forklifts

83 - 90



CERASKAL ve VİNÇLER Hoists

91 - 109



HİDROLİK KRİKO ve EKİPMANLARI High Pressure Hydraulic Tools And Equipments

111 - 160



SAPANLAR ve AKSESUARLARI Sling and Accessories

161 - 172



ENDÜSTRİYEL KALDIRMA EKİPMANLARI Industrial Lifting Equipments

173 - 189



VARİL TAŞIMA - KALDIRMA EKİPMANLARI Drum Lifting - Handling Equipments

189 - 200



İÇİNDEKİLER - INDEX



KALDIRMA SAPANLARI

- Polyester Sapan ve Aksesuarları
- Zincir Sapan ve Aksesuarları (Grade 8 - Grade 10)
- Çelik Halat Sapanlar ve Aksesuarları



ÖZEL KALDIRMA EKİPMANLARI

- Balansör ve çeşitli kaldırma ekipmanları



KANCALAR VE MAPALAR



TRAVERS VE VİNÇ



AĞIR YÜK TAŞIMA VE KALDIRMA

- Ağır Yük Taşıma Arabaları
- Robotlar
- Bobin / Rulo Taşıma Arabaları
- Pnömatik Hava Yastıkları
- Platformlar
- Malzeme ve Personel Liftleri



HİDROLİK KRİKO VE AKSESUARLARI

- Silindirler
- Pompalar
- Hidrolik Çektirmeler
- Hidrolik Ayırıcılar
- Mekanik Krikolar



İTİCİ VE ÇEKİCİ ARAÇLAR

- Hava Tahrikli Yuvarlayıcılar
- Hava Tahrikli İtici
- Hava Tahrikli Çekiciler
- Hava Tahrikli İtici, Çekici ve Yönlendiriciler
- Elektrikli Yuvarlayıcılar - İtici - Çekiciler





■ **Manuel Transpaletler**

Hand Pallet Truck

■ **Rulo Taşıma Transpaletleri**

Roll Pallet Truck

■ **Paslanmaz ve Galvaniz Transpaletler**

Inox and Galvanized Hand Pallet Truck

■ **Terazili Transpaletler**

Hand Pallet Truck With Scale

■ **Manuel Makaslı Transpaletler**

Scissor Lift Pallet Truck

■ **Arazi Transpaletleri**

Rough Terrain Pallet Truck

■ **Akülü Makaslı Transpaletler**

Electric Scissor Lift Pallet Truck

■ **Akülü Transpaletler**

Electric Pallet Truck

TRANSPALETLER
PALLET TRUCKS

TRANSPALET Kısa / HAND PALLET TRUCK Short

NL-DPK 20

Art.No. 50500002

NL-DPK 20

Kaldırma kapasitesi / Capacity		2000	kg
Min. çatal yüksekliği / Min. fork height	(h)	85	mm
Max. çatal yüksekliği / Max. fork height	(h ₁)	200	mm
Yön tekerleği / Steering wheel		180 x 50	mm
Yük tekerleri / Load wheels		80 x 70	mm
Çatal ölçüsü / Size of fork	(e x s)	160 x 60	mm
Dıştan dışa çatal genişliği / Overall fork width	(B)	550	mm
Çatal boyu / Fork length	(L)	800	mm
Ağırlık / Service weight (pre estimate)		62	kg

Kısa / Short



800 mm

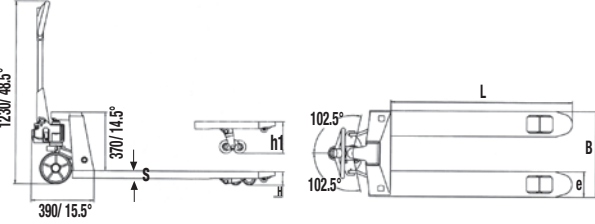

TRANSPALET / HAND PALLET TRUCK

NL-APK

Art.No. 50500055

NL-APK 20

Kaldırma kapasitesi / Capacity		2000	kg
Min. çatal yüksekliği / Min. fork height	(h ₁₃)	85	mm
Çatal ölçüsü / Size of fork	(s/ e/ l)	37 x 160 x 670	mm
Yük merkezi / Load center distance	(c)	350	mm
Teker türü ön/arka / Wheel type front/rear		Poliüretan / Polyurethane	
Yürüyüş tekerlekleri / Driving wheel		147 x 50	mm
Yük tekerleri / Load wheels		50 x 93	mm
Kaldırma yüksekliği / Lifting height	(h ₃ , h ₁₃)	171	mm
Makine uzunluğu / Overall length	(l ₁)	1064	mm
Makine genişliği / Overall width	(b ₁)	490	mm
Dıştan dışa çatal genişliği / Overall fork width		490	mm
Ağırlık / Service weight (pre estimate)		50	kg

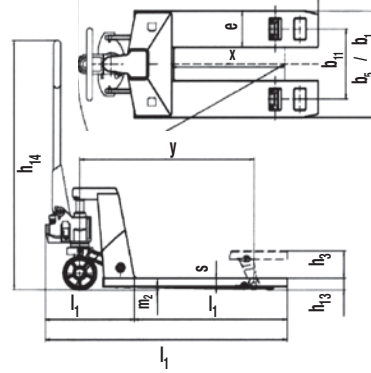
Kısa ve Dar
Short and narrow

490 mm

670 mm



TRANSPALET / HAND PALLET TRUCK

NL-DP 25

Art.No. 50500006

NL-DP 25

Kaldırma kapasitesi / Capacity		2500	kg
Min. çatal yüksekliği / Min. fork height	(h)	85	mm
Max. çatal yüksekliği / Max. fork height	(h ₁)	200	mm
Yön tekerleği / Steering wheel		180 x 50	mm
Yük tekerleri / Load wheels		80 x 70	mm
Çatal ölçüsü / Size of fork	(e x s)	160 x 60	mm
Dıştan dışa çatal genişliği / Overall fork width	(B)	550	mm
Çatal boyu / Fork length	(L)	1150	mm
Ağırlık / Service weight (pre estimate)		67	kg

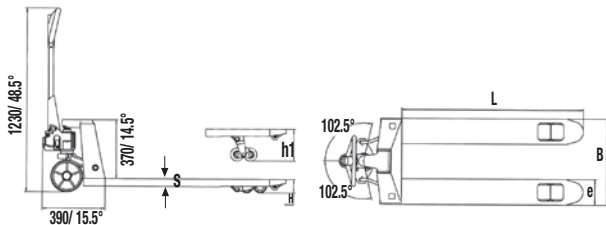

TRANSPALET / HAND PALLET TRUCK

NL-AP 25

Art.No. 50500007

NL-AP 25

Kaldırma kapasitesi / Capacity		2500	kg
Min. çatal yüksekliği / Min. fork height	(h)	85	mm
Max. çatal yüksekliği / Max. fork height	(h ₁)	200	mm
Yön tekerleği / Steering wheel		200 x 50	mm
Yük tekerleri / Load wheels		80 x 70	mm
Çatal ölçüsü / Size of fork	(e x s)	160 x 50	mm
Dıştan dışa çatal genişliği / Overall fork width	(B)	540	mm
Çatal boyu / Fork length	(L)	1150	mm
Ağırlık / Service weight (pre estimate)		70	kg

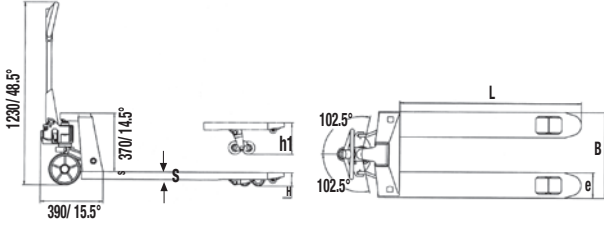

TRANSPALET / HAND PALLET TRUCK

NL-AP 25 CHEROKE

Art.No. 50500008

NL-AP 25 CHEROKE

Kaldırma kapasitesi / Capacity		2500	kg
Min. çatal yüksekliği / Min. fork height	(h)	85	mm
Max. çatal yüksekliği / Max. fork height	(h ₁)	200	mm
Yön tekerleği / Steering wheel		200 x 50	mm
Yük tekerleri / Load wheels		80 x 70	mm
Çatal ölçüsü / Size of fork	(e x s)	160 x 50	mm
Dıştan dışa çatal genişliği / Overall fork width	(B)	685	mm
Çatal boyu / Fork length	(L)	1220	mm
Ağırlık / Service weight (pre estimate)		80	kg

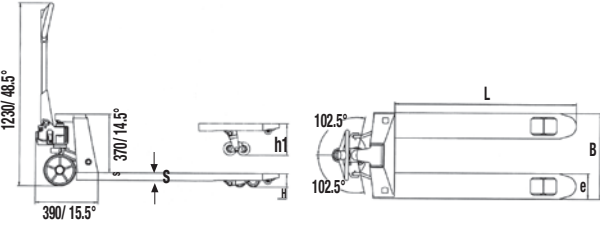

TRANSPALET / HAND PALLET TRUCK

NL-AP 25 MAXI

Art.No. 50500009

NL-AP 25 MAXI

Kaldırma kapasitesi / Capacity		2500	kg
Min. çatal yüksekliği / Min. fork height	(h)	85	mm
Max. çatal yüksekliği / Max. fork height	(h ₁)	200	mm
Yön tekerleği / Steering wheel		200 x 50	mm
Yük tekerleri / Load wheels		80 x 70	mm
Çatal ölçüsü / Size of fork	(e x s)	160 x 50	mm
Dıştan dışa çatal genişliği / Overall fork width	(B)	540	mm
Çatal boyu / Fork length	(L)	1220	mm
Ağırlık / Service weight (pre estimate)		73	kg

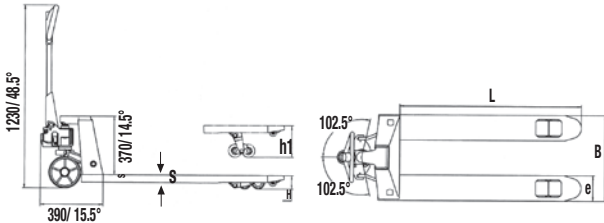

TRANSPALET Frenli / HAND PALLET TRUCK With Brake

NL-AP 25 F

Art.No.50500010

NL-AP 25 F

Kaldırma kapasitesi / Capacity		2500	kg
Min. çatal yüksekliği / Min. fork height (h)		85	mm
Max. çatal yüksekliği / Max. fork height (h ₁)		200	mm
Yön tekerleği / Steering wheel		200 x 50	mm
Yük tekerleri / Load wheels		80 x 70	mm
Çatal ölçüsü / Size of fork (e x s)		160 x 50	mm
Dıştan dışa çatal genişliği / Overall fork width (B)		540	mm
Çatal boyu / Fork length (L)		1150	mm
Ağırlık / Service weight (pre estimate)		77	kg

Frenli / With Brake



Progresif Fren Sistemi
Progressive Brake

TRANSPALET / HAND PALLET TRUCK

NL-AP 30

Art.No.50500012

NL-AP 30

Kaldırma kapasitesi / Capacity		3000	kg
Min. çatal yüksekliği / Min. fork height (h)		85	mm
Max. çatal yüksekliği / Max. fork height (h ₁)		200	mm
Yön tekerleği / Steering wheel		200 x 50	mm
Yük tekerleri / Load wheels		80 x 70	mm
Çatal ölçüsü / Size of fork (e x s)		160 x 60	mm
Dıştan dışa çatal genişliği / Overall fork width (B)		540	mm
Çatal boyu / Fork length (L)		1150	mm
Ağırlık / Service weight (pre estimate)		78	kg

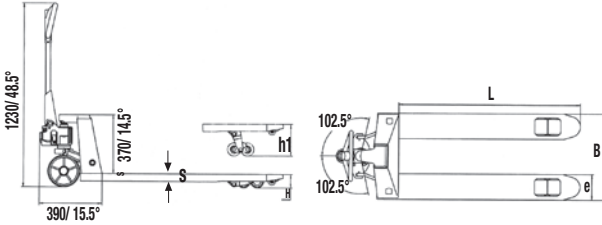

TRANSPALET / HAND PALLET TRUCK

NL-HD 35

Art.No.50500013

NL-HD 35

Kaldırma kapasitesi / Capacity		3500	kg
Min. çatal yüksekliği / Min. fork height (h)		85	mm
Max. çatal yüksekliği / Max. fork height (h ₁)		200	mm
Yön tekerleği / Steering wheel		200 x 50	mm
Yük tekerleri / Load wheels		80 x 70	mm
Çatal ölçüsü / Size of fork (e x s)		175 x 60	mm
Dıştan dışa çatal genişliği / Overall fork width (B)		520	mm
Çatal boyu / Fork length (L)		1150	mm
Ağırlık / Service weight (pre estimate)		86	kg

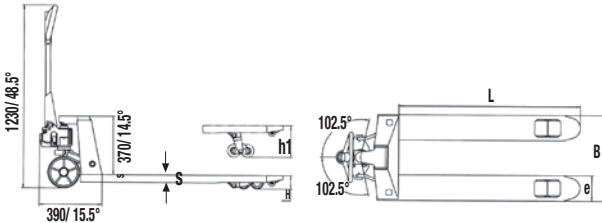

TRANSPALET / HAND PALLET TRUCK

NL-APA 51

Art.No. 50500014

NL-APA 51

Kaldırma kapasitesi / Capacity		1500	kg
Min. çatal yüksekliği / Min. fork height (h)		51	mm
Max. çatal yüksekliği / Max. fork height (h ₁)		165	mm
Yön tekerleği / Steering wheel		180 x 50	mm
Yük tekerleri / Load wheels		50 x 70	mm
Çatal ölçüsü / Size of fork (e x s)		160 x 37	mm
Dıştan dışa çatal genişliği / Overall fork width (B)		540	mm
Çatal boyu / Fork length (L)		1150	mm
Ağırlık / Service weight (pre estimate)		85	kg

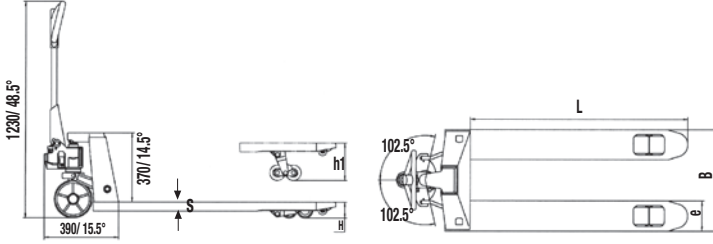

TRANSPALET / HAND PALLET TRUCK

NL-APA 35

Art.No. 50500015

NL-APA 35

Kaldırma kapasitesi / Capacity		1000	kg
Min. çatal yüksekliği / Min. fork height (h)		35	mm
Max. çatal yüksekliği / Max. fork height (h ₁)		90	mm
Yön tekerleği / Steering wheel		160 x 50	mm
Yük tekerleri / Load wheels		34 x 58	mm
Çatal ölçüsü / Size of fork (e x s)		160 x 30	mm
Dıştan dışa çatal genişliği / Overall fork width (B)		530	mm
Çatal boyu / Fork length (L)		1120	mm
Ağırlık / Service weight (pre estimate)		104	kg

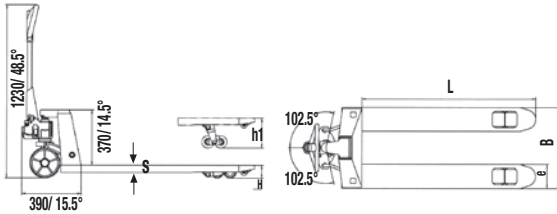

TRANSPALET / HAND PALLET TRUCK

NL-H 20

Art.No. 50500016

NL-H 20

Kaldırma kapasitesi / Capacity		2000	kg
Min. çatal yüksekliği / Min. fork height (h)		85	mm
Max. çatal yüksekliği / Max. fork height (h ₁)		200	mm
Yön tekerleği / Steering wheel		200 x 50	mm
Yük tekerleri / Load wheels		80 x 70	mm
Çatal ölçüsü / Size of fork (e x s)		160 x 60	mm
Dıştan dışa çatal genişliği / Overall fork width (B)		550	mm
Çatal boyu / Fork length (L)		1150	mm
Ağırlık / Service weight (pre estimate)		82	kg

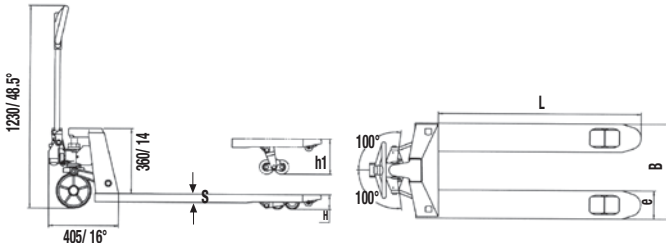

TRANSPALET Ağır Hizmet / PALLET TRUCK Heavy Duty

NL-HD 40

Art.No. 50500051

NL-HD 40

Kaldırma kapasitesi / Capacity	4000	kg
Min. çatal yüksekliği / Min. fork height	85	mm
Max. çatal yüksekliği / Max. fork height	185	mm
Çatal dış mesafesi / Fork outside distance	550	mm
Çatal boyu / Fork length	1200	mm
Dıştan dışa çatal genişliği / Overall fork width	550	mm
Teker türü ön/arka / Wheel type front/rear	Döküm teker / Cast Wheels	
Ağırlık / Service weight (pre estimate)	159	kg

Ağır Hizmet / Heavy Duty



TRANSPALET Ağır Hizmet / HAND PALLET TRUCK Heavy Duty

NL-HD 50

Art.No. 50500017

NL-HD 50

Kaldırma kapasitesi / Capacity	5000	kg
Min. çatal yüksekliği / Min. fork height	90	mm
Max. çatal yüksekliği / Max. fork height	200	mm
Yön tekerleği / Steering wheel	200 x 50	mm
Yük tekerleri / Load wheels	80 x 68	mm
Çatal genişliği / Fork width	210	mm
Dıştan dışa çatal genişliği / Overall fork width	580	mm
Çatal boyu / Fork length	1150	mm
Ölçüler / Over size	1546 x 588 x 1300	mm
Teker türü ön/arka / Wheel type front/rear	Döküm teker / Cast Wheels	
Ağırlık / Service weight (pre estimate)	192	kg

Ağır Hizmet / Heavy Duty



- Ağır yükler için özel tasarlanmıştır.
- Eşsiz hidrolik pompa sayesinde az güç sarfıyatı ile ağır yükler kaldırılır.
- CE güvenlik standartına uygundur.

- Heavy duty design for handling heavy load.
- Unique hydraulic pump with less effort to lift heavy load easily.
- Conforms to CE safety standard.

TRANSPALET / HAND PALLET TRUCK Super Long

NL-APU 10 / 20

Art.No. 50500019

NL-APU 10/20

Kaldırma kapasitesi / Capacity	1000	kg
Min. çatal yüksekliği / Min. fork height (h)	85	mm
Max. çatal yüksekliği / Max. fork height (h ₁)	200	mm
Yön tekerleği / Steering wheel	200 x 50	mm
Yük tekerleri / Load wheels	80 x 70	mm
Çatal ölçüsü / Size of fork (e x s)	160 x 60	mm
Dıştan dışa çatal genişliği / Overall fork width (B)	540	mm
Çatal boyu / Fork length (L)	2000	mm
Ağırlık / Service weight (pre estimate)	131	kg

Uzun / Long



TRANSPALET Uzun / HAND PALLET TRUCK Long

	NL-APU 20/1.5	NL-APU 20/1.8	NL-APU 20/2.0	
Kaldırma kapasitesi / Capacity	2000	2000	2000	kg
Min. çatal yüksekliği / Min. fork height	85	85	85	mm
Max. çatal yüksekliği / Max. fork height	200	200	200	mm
Yön tekerleği / Steering wheel	200 x 50	200 x 50	200 x 50	mm
Yük tekerleri / Load wheels	82 x 70	82 x 70	82 x 70	mm
Çatal ölçüsü / Size of fork	160 x 60	160 x 60	160 x 60	mm
Dıştan dışa çatal genişliği / Overall fork width	540	540	540	mm
Çatal boyu / Fork length	1500	1800	2000	mm
Ağırlık / Service weight (pre estimate)	96	111	118	kg

Art.No. 50500018	NL-APU 20/1.5
Art.No. 50500060	NL-APU 20/1.8
Art.No. 50500059	NL-APU 20/2.0

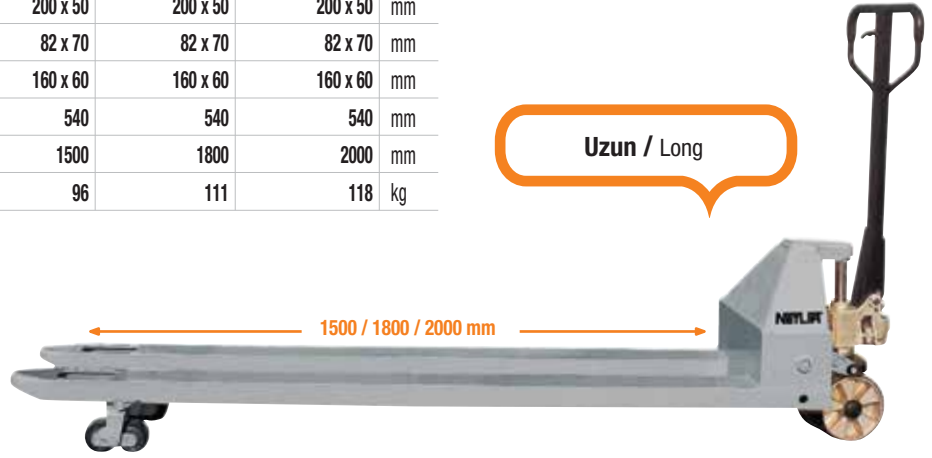

TRANSPALET Uzun / HAND PALLET TRUCK Long

	NL-APU 35/20	
Kaldırma kapasitesi / Capacity	3500	kg
Min. çatal yüksekliği / Min. fork height	85	mm
Max. çatal yüksekliği / Max. fork height	200	mm
Yön tekerleği / Steering wheel	200 x 50	mm
Yük tekerleri / Load wheels	82 x 70	mm
Çatal ölçüsü / Size of fork	160 x 60	mm
Dıştan dışa çatal genişliği / Overall fork width	540	mm
Çatal boyu / Fork length	2000	mm
Ağırlık / Service weight (pre estimate)	245	kg

Art.No. 50500062	NL-APU 35/20
------------------	--------------

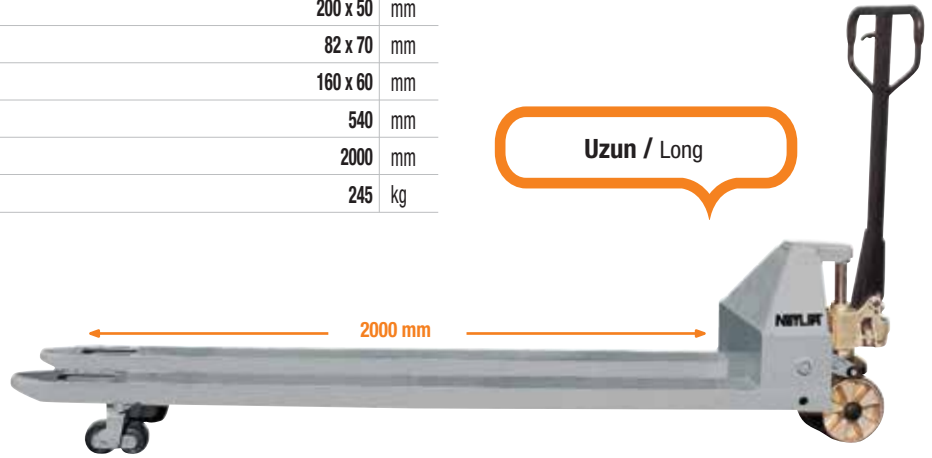

RULO TAŞIMA TRANSPALETİ / ROLL PALLET TRUCK

	NL-AP 20R 500	NL-AP 20R 700	NL-AP 20R 1000	NL-AP 20R 1500	
Kaldırma kapasitesi / Capacity	2000	2000	2000	2000	kg
Rulo çapı / Reel diameter	400-600	600-800	800-1200	1200-1600	mm
Dıştan dışa çatal genişliği / Overall fork width	760	850	1000	1150	mm
Yön tekerleği / Steering wheel	200 x 50	200 x 50	200 x 50	200 x 50	mm
Yük tekerleri / Load wheels	80 x 70	80 x 70	80 x 70	80 x 70	mm
Çatal uzunluğu / Fork length	1000	1000	1000	1000	mm
Ağırlık / Service weight (pre estimate)	124	129	142	145	kg

Art.No. 50500020	NL-AP 20 R 500
Art.No. 50500021	NL-AP 20 R 700
Art.No. 50500022	NL-AP 20 R 1000
Art.No. 50500023	NL-AP 20 R 1500

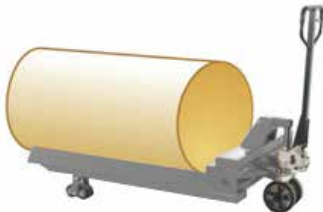

DÖRT YÖNLÜ TRANSPALET / 4 WAY ROLLER PALLET TRUCK

NL-TWO 15

Art.No. 50500024

NL-TWO 15

Kaldırma kapasitesi / Capacity		1500	kg
Min. çatal yüksekliği / Min. fork height (h)		85	mm
Max. çatal yüksekliği / Max. fork height (h ₁)		210	mm
Yön tekerleği / Steering wheel		200 x 50	mm
Yük tekerleri / Load wheels		65 x 65	mm
Çatal ölçüsü / Size of fork (e x s)		160 x 50	mm
Dıştan dışa çatal genişliği / Overall fork width (B)		540	mm
Çatal boyu / Fork length (L)		1150	mm
Ağırlık / Service weight (pre estimate)		86	kg

* 4 Yöne hareket olanağı

* 4 Way moving



TRANSPALET / HAND PALLET TRUCK

INOX NL-APP 20H

INOX NL-APP 25H

NL-APG 20H

Kaldırma kapasitesi / Capacity		2000	2500	2000	kg
Min. çatal yüksekliği / Min. fork height (h)		85	80	85	mm
Max. çatal yüksekliği / Max. fork height (h ₁)		200	200	200	mm
Yön tekerleği / Steering wheel		200 x 50	180 x 50	200 x 50	mm
Yük tekerleri / Load wheels		80 x 70	80 x 70	80 x 70	mm
Çatal ölçüsü / Size of fork (e x s)		160 x 60	160 x 60	160 x 60	mm
Dıştan dışa çatal genişliği / Overall fork width (B)		540	550	540	mm
Çatal boyu / Fork length (L)		1150	1220	1150	mm
Teker türü ön/arka / Wheel type front/rear		Poliamid	Poliamid	Poliamid	
Ağırlık / Service weight (pre estimate)		70	73	72	kg
Malzeme / Material		Paslanmaz	Paslanmaz	Galvaniz	

Art.No. 50500025

INOX NL-APP 20H

Art.No. 50500066

INOX NL-APP 25H

Art.No. 50500026

NL-APG 20H

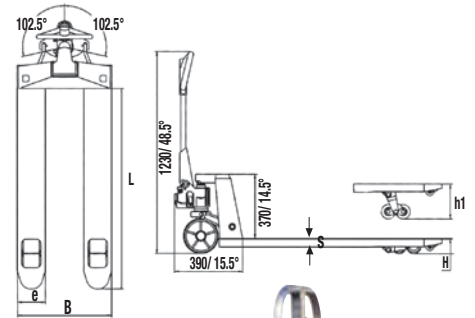

INOX / Paslanmaz



INOX NL-APP 25H

GALVANİZ / Galvanized



NL-APG 20H

TRANSPALET / HAND PALLET TRUCK

NL-DELTA 26

Art.No. 50500047

NL-DELTA 26

Kaldırma kapasitesi / Capacity	2600	kg
Min. çatal yüksekliği / Min. fork height	85	mm
Max. çatal yüksekliği / Max. fork height	200	mm
Yön tekerleği / Steering wheel	200 x 50	mm
Yük tekerleri / Load wheels	80 x 70	mm
Çatal ölçüsü / Size of fork	160 x 50	mm
Dıştan dışa çatal genişliği / Overall fork width	540	mm
Çatal boyu / Fork length	1150	mm
Ağırlık / Service weight (pre estimate)	73	kg

- Depolama ve nakliye işlerinizde profesyonel çözüm ortağınız.
- Güçlendirilmiş ve galvanize edilmiş parçalar ile uzun ömür, yüksek performans.
- Özel yürüyüş sistemi ve "Anti shock" özelliği ile donatılmış bağlantı elemanları sayesinde en düşük gürültü seviyesi (Kapalı alanlar ve üst katlarda kullanım için ideal ürün)
- "Master ring" özelliği sayesinde sağ ve sol dönüşlerde operatör için büyük manevra kolaylığı.
- Paleta ilk temasta gövde deformasyonunu önleyen darbe emici form çatal yapısı "Fork absorber"
- Professional solution partner for your storage and transportation works.
- Long life and high performance with strengthened and galvanized items.
- Lowest noise level thanks to the connectors that are equipped with special walking system and "Anti-shock" features (ideal for application in indoor areas and upper floors)
- Effortless manoeuvring for operator in the right and left turns thanks to the "Master ring" feature.
- Shock absorber form fork structure "Fork absorber" that prevents body deformation in the first contact with pallet.



TRANSPALET / HAND PALLET TRUCK

NL-ALFA 27

Art.No. 50500053

NL-ALFA 27

Kaldırma kapasitesi / Capacity	2700	kg
Min. çatal yüksekliği / Min. fork height	85	mm
Max. çatal yüksekliği / Max. fork height	200	mm
Yön tekerleği / Steering wheel	200 x 50	mm
Yük tekerleri / Load wheels	80 x 70	mm
Çatal ölçüsü / Size of fork	160 x 60	mm
Dıştan dışa çatal genişliği / Overall fork width	540	mm
Çatal boyu / Fork length	1150	mm
Dönme yarıçapı / Turning radius	1335	mm
Koridor genişliği / Aisle width	1790	mm
Ağırlık / Service weight (pre estimate)	80	kg

- ALFA 27 özel tasarımı yerel ve uluslararası alanda patentlidir.
- Aşırı yük koruma valfi ile yükün ve aynı zamanda operatörün emniyeti sağlanmıştır.
- Özellikle hassas yüklerin emniyeti için otomatik yavaş indirme sistemi geliştirilmiştir.
- Özel, krom kaplı piston mili ile yüksek dayanım sağlanmıştır.
- Hareketli bağlantılarda yüksek aşınma dayanımı, uzun kullanım ömrü ve kolay değiştirilebilirliği olan "Plastik Kayar Rulmanlar" kullanarak eksantrik yükleri rahatça absorbe etmesi sağlanmıştır.
- ALFA 27 special design is nationally and internationally patented.
- Over load protection valve ensures safety of the cargos as well as operator. • Automatic slow lowering system was developed to protect the fragile cargo.
- High strength was ensured with the special chrome-plated piston pin
- Rotating joints are equipped with engineering "Plastic Sliding Bearings", able to absorb eccentric load, with better wear resistance, extended using life and easy replacement.



- İntegral çatal yapısı ile geleneksel kaynaklı modellere göre daha güçlü yapı
- Alman teknolojisi döküm pompa ve yekpare hidrolik valf kaseti ile kullanım ve bakım kolaylığı

- With unique integral forks, the intensity is stronger than the traditional welding forks
- Easy application and maintenance with the German technology AC type pump and unique hydraulic valve cartridge



- Plastik korumalı gövde ile hatalı kullanım sonucu yüke zarar gelmesini önleyici koruma
- Backrest with rubber protection, minimize the collision caused by careless operation, to better protect the loaded cargos.



- Güçlendirilmiş çatal yapısı ile geleneksel transpaletlerden daha dayanıklı gövde
- With the strengthened fork structure, more resistant body comparing to traditional ones



- Dayanımı yüksek oval şase boynuzu tasarımı
- Moon shape thrust plate to make the whole outline more harmonius, also strong enough



TRANSPALET Terazili / HAND PALLET TRUCK With Scale	NL-T 20 (HPS 20)	NL-TP 20 (HSP 20)	NL- T 20 INOX	
Kaldırma kapasitesi / Capacity	2000	2000	2000	kg
Min. çatal yüksekliği / Min. fork height (h ₁)	85	85	85	mm
Max. çatal yüksekliği / Max. fork height (h ₂)	200	200	195	mm
Yön tekerleği / Steering wheel (d)	180 x 50	180 x 50	180x50	mm
Yük tekerleri / Load wheels (d ₁)	74 x 70	74 x 70	74 x 70	mm
Çatal ölçüsü / Size of fork (c x h)	182 x 50	182 x 50	180 x 50	mm
Dıştan dışa çatal genişliği / Overall fork width (B)	557	557	542	mm
Çatal boyu / Fork length (A)	1150	1150	1150	mm
Maks. hata / Max. error	0.05	0.05	2000 kg yükte +/- 2 kg sapma	%
Güç kaynağı / Power supply	6V/4.Ah	6V/4.Ah	DC 1.5V x 4	V/Ah
Teker türü ön/arka / Wheel type front/rear	PU	PU	PA	
Ağırlık / Service weight (pre estimate)	94	94	110	kg

Art.No. 50500027	NL-T 20
Art.No. 50500028	NL-TP 20
Art.No. 50500033	NL-T20 INOX

NL-T 20 ve NL-TP 20 Özellikleri

- Yüksek çözünürlüklü ekran
- Toplama fonksiyonu
- Birim değiştirme
- Çoklu işlev tuşları
- Yüksek doğruluk
- İsteğe bağlı yazıcı
- Şarj edilebilir pil

NL-T 20 and NL-TP 20 Features

- High definition display
- Totalising function
- Unit switching
- Multiple function keys
- High Accuracy
- Optional printer
- Build-rechargeable battery

NL- T 20 INOX Özellikleri

- 6 dijit 1.2 LED ekran
- 7 fonksiyon buton
- IP5x koruma seviyesi
- +5VDC voltaj
- 6V / 4Ah pil
- -10°C+ 40°C, çalışma sıcaklık aralığı ve %85 nem seviyesi altında çalışma imkanı

NL- T 20 INOX Features

- 6 digit 1.2-inch LED display
- 7 function buttons
- Protection level: IP5x
- Excitation voltage: +5VDC
- Battery: 6V / 4Ah
- Operating temperature: -10°C - 40°C, relative humidity is below 85%



Terazili & Yazıcı



Terazili



NL- TP 20

NL- T 20

TRANSPALET Teleskobik Makaslı / TELESCOPIC SCISSOR LIFT PALLET TRUCK

	NL-M 10	NL-M 15	
Kaldırma kapasitesi / Capacity	1000	1500	kg
Min. çatal yüksekliği / Min. fork height	85	85	mm
Max. çatal yüksekliği / Max. fork height	800	800	mm
Yön tekerleği / Steering wheel	180 x 50	180 x 50	mm
Yük tekerleri / Load wheels	80 x 50	80 x 50	mm
Dıştan dışa çatal genişliği / Overall fork width	540	540	mm
Çatal boyu / Fork length	1150	1150	mm
Ağırlık / Weight (pre estimate)	93	98	kg

Art.No. 50500029-1

NL-M 10

Art.No. 50500029-1,5

NL-M 15



Art.No. 50500031

NL-MP 10

TRANSPALET Makaslı (Paslanmaz) / SCISSOR LIFT PALLET TRUCK (Inox)

	NL-MP 10	
Kaldırma kapasitesi / Capacity	1000	kg
Min. çatal yüksekliği / Min. fork height	85	mm
Max. çatal yüksekliği / Max. fork height	800	mm
Yön tekerleği / Steering wheel	180 x 50	mm
Yük tekerleri / Load wheels	80 x 50	mm
Çatal ölçüsü / Size of fork	162 x 50	mm
Dıştan dışa çatal genişliği / Overall fork width	540	mm
Çatal boyu / Fork length	1150	mm
Ağırlık / Service weight (pre estimate)	118	kg
Teker türü ön/arka / Wheel type front/rear	Poliamid / Polyamide	

INOX / Paslanmaz



Art.No. 50500035

NL-ART 12

ARAZİ TRANSPALETİ / ROUGH TERRAIN PALLET TRUCK

	NL-ART 12	
Kaldırma kapasitesi / Capacity	1200	kg
Min. çatal yüksekliği / Min. fork height (h min.)	63	mm
Maks. çatal yüksekliği / Max. fork height (h maks.)	233	mm
Yön tekerleği / Steering wheel	265 x 80	mm
Yük tekerleri / Load wheels	550 x 132	mm
Çatal boyu / Fork length (l _f)	860	mm
Çatal genişliği / Fork width (e)	100	mm
Dıştan dışa çatal genişliği / Overall fork width (W ₁ -W ₂)	212- 735	mm
Genel ebatlar / Overall size (L x W x H)	1375 x 1605 x 1200	mm
Yük merkezi / Load center (c)	450	mm
Max.pompa stroku / Max.pump stroke	170	mm
Ağırlık / Service weight (pre estimate)	225	kg

- Bu model, inşaat sahası, bahçeler veya forkliftin giremeyeceği yerlerde özel kullanım içindir.
- Geniş tekerlekleri ve kasası, ayarlanabilir çatalın sayesinde bir çok tip palette ve düz olmayan, pürüzlü yüzeylerde kullanılabilir.
- Kontrol kolu kaldırma, indirme ve nötral hareket olarak 3 pozisyondan oluşmaktadır. Bu da makinenin kullanımını kolay ve güvenli yapar.

Arazi Transpaleti

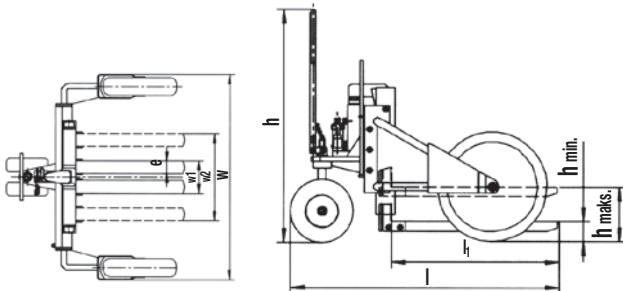

Makaslı - Akülü Makaslı TRANSPALET / SCISSOR LIFT PALLET TRUCK

	NL-HLTN 10	NL-EX	
Kaldırma kapasitesi / Capacity	1000	1000	kg
Yük merkezi / Load centre distance	600	600	mm
Tekerlek mesafesi / Wheel base (y)	1310	1310	mm
Ağırlık (akü dahil) / Service weight (with battery)	105	140	kg
Tekerlek tipi / Tyres	Poliüretan / Polyurethane		
Tekerlek ölçüsü (ön) / Tyre size (front)	ø180x50	ø180x50	mm
Tekerlek ölçüsü (arka) / Tyre size (rear)	ø75x50	ø75x50	mm
Teker arası mesafe (ön) / Track width (front) (b ₁₀)	155	155	mm
Teker arası mesafe (arka) / Track width (rear) (b ₁₁)	440	440	mm
Kaldırma yüksekliği / Lifting height (h ₃)	800	800	mm
Min. çatal yüksekliği / Min. fork height (h ₁₃)	85	85	mm
Makine uzunluğu / Overall length (l ₁)	1725	1715	mm
Çatal gövdesine kadar uzunluk / Length to face of forks (l ₂)	492	492	mm
Makine genişliği / Overall width (b ₁)	520	520	mm
Çatal ölçüleri / Fork dimensions (s/e/l)	45/160/1140	45/160/1140	mm
Dıştan dışa çatal genişliği / Fork width (b ₅)	520	520	mm
Gövde yerden yüksekliği / Ground clearance, centre of wheelbase (m ₂)	18	18	mm
Dönme yarıçapı / Turning radius (Wa)	1564	1564	mm
Kaldırma hızı (yükü/yüksüz) / Lifting speed (with/without load)	-	21/45	m/sn
İndirme hızı (yükü/yüksüz) / Lowering speed (with/without load)	-	81-61	m/sn
Kaldırma motoru / Lifting Motor	-	0.6	kW
Akü / Battery	-	12V/66	V/Ah
Akü ağırlığı / Battery weight	-	24	kg

MANUEL
AKÜLÜ

Art.No. 50500030

NL-HLT N 10

Art.No. 50500032

NL-EX

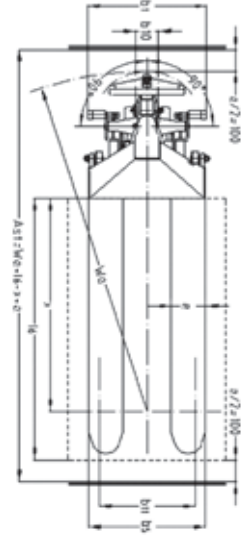
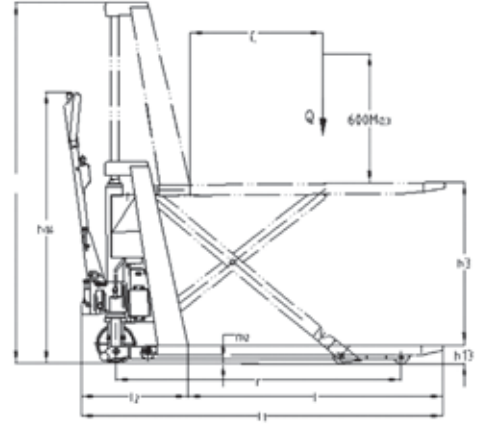

200 kg.'a kadar olan yükleri "hızlı kaldırma" fonksiyonu ile daha hızlı kaldırır.



400 mm in altında transpalet olarak görev yapar.



Akü ile kaldırma işlemi artık daha kolay ve hızlı



Akülü modellerde yer alan anahtar

NL-HLTN 10
MANUELNL-EX
AKÜLÜDAHİLİ ŞARJ CİHAZI
INTERNAL CHARGER

Art.No. 50500038

NL-FEPT 18 AC Li

AKÜLÜ TRANSPALET / ELECTRIC PALLET TRUCK

NL-FEPT 18 AC Li

Kapasite / Capacity	1800	kg
Kaldırma yüksekliği / Lifting height	115	mm
Makine uzunluğu / Overall length	1625	mm
Makine genişliği / Overall width	645	mm
Yük merkezi mesafesi / Load center distance	600	mm
Yük merkezinin gövdeye mesafesi / Load distance	945	mm
Çatal gövdesine kadarki uzunluk / Length to face of forks	475	mm
Çatal ölçüleri / Fork dimensions	50 x 150 x 1150	mm
Min.yükseklik / Lowered height	85	mm
Makine yüksekliği / Ground clearance	35	mm
Yürüyüş hızı (yükli/yüksüz) / Driving speed (laden/unladen)	5.5/6	km/h
Tırmanma kabiliyeti (yükli/yüksüz) / Gradeability (laden/unladen)	6/16	%
Yürüyüş motoru / Driving motor	1.1	kW
Kaldırma motoru / Lifting motor	0.84	kW
Ağırlık (akü dahil) / Service weight include of battery	285	kg
Akü / Battery	24/85	V/Ah
Kontrol tipi / Controller type	AC	
Dıştan dışa çatal genişliği / Overall fork width	540	mm
Teker türü / Wheel type	PU	



Lityum-ion akü avantajları

- + İstenildiği zaman şarj etme imkanı
- + Standart şarj cihazı ile 2,5 saatte tam şarj
- + Bakım gerektirmez.
- + Şarj esnasında gaz çıkışı olmaz.
- + Yedek aküye ihtiyaç duymaz
- + Harici şarj cihazı ile bağımsız akü şarj etme imkanı

Advantages of Lityum-ion battery

- + Charge whenever desired.
- + Fully charging in 2.5 hours with standard charger.
- + No maintenance
- + No gas during charging
- + Continuous operation without spare battery
- + Charging with external charger



DAHİLİ ŞARJ CİHAZI
INTERNAL CHARGER



GÖSTERGE (çalışma saati ve akü şarj durumu)
INDICATOR (operation hour and charge level)

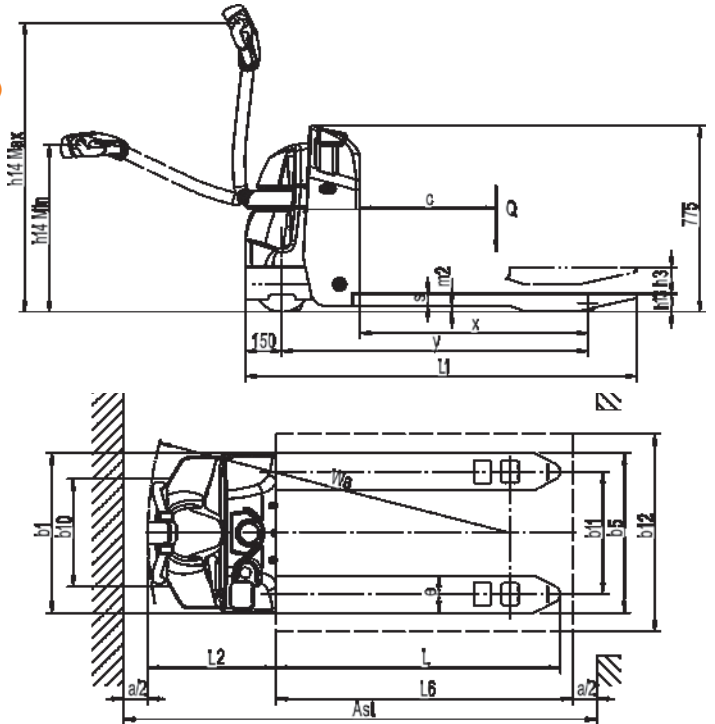

MAKSİMUM PERFORMANS
High performance

KONFOR
Comfort

GÜVENLİ
Safe

ERGONOMİ
Ergonomic

FONKSİYONEL
Functional

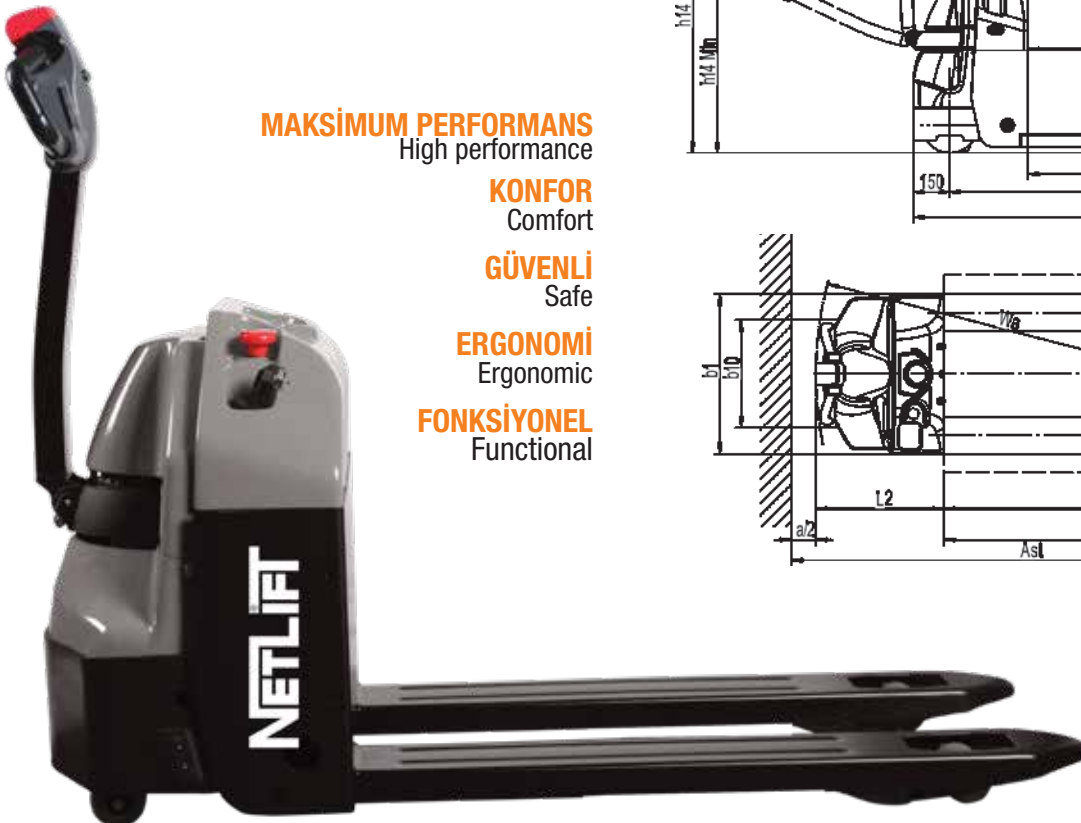

AKÜLÜ TRANSPALET / POWERED PALLET TRUCK

NL-FEPT 20 E Li

Art.No. 50500041-2

NL-FEPT 20 E Li

Kaldırma kapasitesi / Capacity	(Q)	2000 kg
Yük merkezi / Load center	(C)	600 mm
Kullanım şekli / Operator type		Yaya
Elektrikli direksiyon / Electric power steering	(EPS)	Standart ekipman
Kaldırma yüksekliği / Lift height	(h3)	140 mm
Standart çatal genişliği / Standart fork width	(b1)	540 mm
Çatal uzunluğu / Fork length	(L)	1170 mm
Çatal kalınlığı / Fork thickness	(S)	55 mm
Çatal genişliği / Fork width	(E)	170 mm
Makine boyu / Overall length	(l1)	1592 mm
Sürüşte kontrol kolu yüksekliği / Height of tiller arm in operating position, min./max	(h5)	716/1240 mm
Makine genişliği / Overall width	(B1/B2)	645/625 mm
Dönme yarıçapı / Turning radius		1428 mm
Koridor genişliği (800x1200 palet) uzunlamasına / Aisle width for pallets 800x1200 lengthways	(Ast)	2076 mm
Koridor genişliği (1000x1200 palet) uzunlamasına / Aisle width for pallets 1000x1200 lengthways	(Ast)	2228 mm
Yürüş hızı (yükli/yüksüz) / Driving speed (with/without load)		5 / 5.5 km/h
Kaldırma hızı (yükli/yüksüz) / Lift speed (with/without load)		0.028 / 0.04 m/sn
İndirme hızı (yükli/yüksüz) / Lowering speed (with/without load)		0.04 / 0.022 m/sn
Tırmanma kabiliyeti (yükli/yüksüz) / Gradient (with/without load, mit)		6 / 16 %
Ağırlık (akü dahil) / Service weight (with battery)		250 kg
Tekerlek tipi / Tyres		Poliüretan
Tekerlek adedi / Wheel quantity (drive/load)		1x +2/4
Yürüş teker ölçüsü / Size of steering wheel		ø 245x94 mm
Yük tekeri / Size of loading wheel		ø 80x85 mm
Denge teker ölçüsü / Tyre size balance wheel		ø 74x48 mm
Yürüş motoru / Driving motor		0.9 kW
Kaldırma motoru / Lifting Motor		0.84 kW
Akü / Battery voltage, nominal capacity		48/30 li-ion V/Ah



Lityum-ion akü avantajları

- + İstenildiği zaman şarj etme imkanı
- + Standart şarj cihazı ile 2,5 saatte tam şarj
- + Bakım gerektirmez.
- + Şarj esnasında gaz çıkışı olmaz.
- + Yedek aküye ihtiyaç duymaz
- + Harici şarj cihazı ile bağımsız akü şarj etme imkanı

Advantages of Lityum-ion battery

- + Charge whenever desired.
- + Fully charging in 2.5 hours with standard charger.
- + No maintenance
- + No gas during charging
- + Continuous operation without spare battery
- + Charging with external charger

- Daha kompakt daha güçlü gövde yapısı
- Yeniden tasarlanmış işlevsel kumanda kolu
- Kolay bakım sağlayan ergonomik tasarım
- More compact and stronger body structure
- Redesigned functional controller arm
- Ergonomic Design for easy maintenance

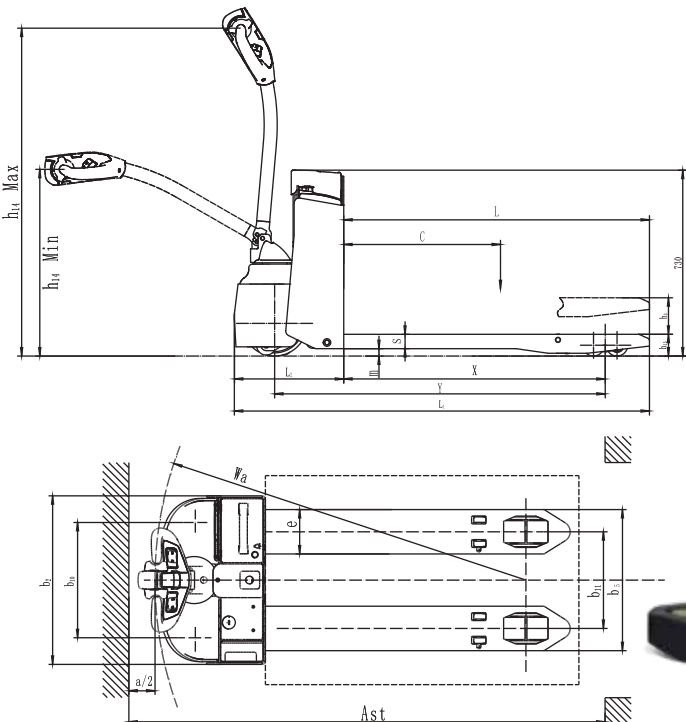
DAHİLİ ŞARJ CİHAZI
INTERNAL CHARGER

AKÜLÜ TRANSPALET / POWERED PALLET TRUCK

FEPT 20 H Li

Art.No. 50500040-3

NL-FEPT 20 H Li

Kaldırma kapasitesi / Capacity	(Q)	2000 kg
Yük merkezi / Load center	(C)	600 mm
Kullanım şekli / Operator type		Ayakta
Elektrikli direksiyon / Electric power steering	(EPS)	Standart ekipman
Kaldırma yüksekliği / Lift height	(h3)	120 mm
Gövde yerden yüksekliği / Ground clearance	(h2)	85 mm
Standart çatal genişliği / Standart fork width	(b1)	540 mm
Çatal uzunluğu / Fork length	(L)	1150 mm
Çatal kalınlığı / Fork thickness	(S)	55 mm
Çatal genişliği / Fork width	(E)	170 mm
Makine boyu / Overall length	(I1)	1866 mm
Kaldırma yüksekliği / Lift height	(h3)	120 mm
Arka gövde yüksekliği / Rear body height	(h4)	730 mm
Sürüşte kontrol kolu yüksekliği /		1075/1288 mm
Height of tiller arm in operating position, min./max.	(h14)	
Makine genişliği / Overall width	(B)	730 mm
Dönme yarıçapı / Turning radius		1700 mm
Koridor genişliği (800x1200 palet) uzunlamasına /		2355 mm
Aisle width for pallets 800x1200 lengthways	(Ast)	
Koridor genişliği (1000x1200 palet) uzunlamasına /		2498 mm
Aisle width for pallets 1000x1200 lengthways	(Ast)	
Yürüyüş hızı (yükli/yüksüz) / Driving speed (with/without load)		5.5 / 6 km/h
Kaldırma hızı (yükli/yüksüz) / Lift speed (with/without load)		0.050 / 0.054 m/sn
İndirme hızı (yükli/yüksüz) / Lowering speed (with/without load)		0.067 / 0.054 m/sn
Tırmanma kabiliyeti (yükli/yüksüz) / Gradient (with/without load, mit)		8/16 %
Ağırlık (akü dahil) / Service weight (with battery)		630 kg
Tekerlek tipi / Tyres		Poliüretan
Tekerlek miktarı / Wheel quantity(drive/load)		1x +2/4
Yürüyüş teker ölçüsü / Size of steering wheel		ø230x75 mm
Yük tekeri ölçüsü / Size of loading wheel	(D1)	ø85x70 mm
Denge teker ölçüsü / Tyre size balance wheel		ø130x55 mm
Tekerlek merkezi / Wheel base	(Y)	1414 mm
Yürüyüş motoru / Driving motor		1.6 kW
Kaldırma motoru / Lifting Motor		2.2 kW
Akü / Battery voltage, nominal capacity		24/210 li-ion V/Ah



Lityum-ion akü avantajları

- + İstenildiği zaman şarj etme imkanı
- + Standart şarj cihazı ile 2,5 saatte tam şarj
- + Bakım gerektirmez.
- + Şarj esnasında gaz çıkışı olmaz.
- + Yedek aküye ihtiyaç duymaz
- + Harici şarj cihazı ile bağımsız akü şarj etme imkanı

Advantages of Lityum-ion battery

- + Charge whenever desired.
- + Fully charging in 2.5 hours with standard charger.
- + No maintenance
- + No gas during charging
- + Continuous operation without spare battery
- + Charging with external charger

HARİCİ ŞARJ CİHAZI

EXTERNAL CHARGER

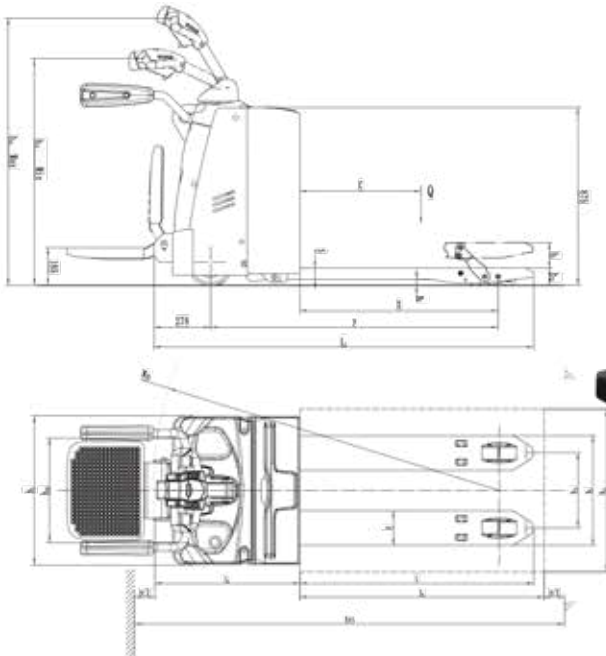

Performans / Performance



1. AC sürüş sistemi daha yüksek tepki hızı, hassas kontrol, daha uzun akü ömrü ve mükemmel performans sağlar.
2. Yeni dizayn fren sistemi daha az enerji tüketimi ve yüksek verimlilik sağlar.
3. Yüksek mukavemete sahip gövde yapısı zor çalışma alanları için uygundur ve daha uzun hizmet ömrü sağlar.
4. Palet taşınmasındaki kusursuz performansı, çalışma verimini artırır.

1. The innovative AC system offers quick response, accurate control, impact structure, excellent performance, longer battery service life.
2. Advanced regenerative braking guarantee low-energy consumption, increasing the efficiency.
3. High-strength frame design, suitable for tough workplaces, ensures longer service life.
4. Excellent performance of getting in and out of empty pallet, greatly increases the operation efficiency.



1. Unique arc board designed on the front frame ensures the clearance between front and rear frames stay constant, avoid the accident of clipping finger.
2. Anti-roll back prevents uncontrolled traveled travel speed or roll-back on ramps when loading and unloading.
3. Emergency plug mounted at up-right side on truck frame, all power can be cut off by simply pulling emergency plug and the truck stops

Emniyet / Safety

1. Ön ve arka panel arasında parmak sıkışmasını önleyen özel tasarımı panel arka yapısı.
2. Kontrolsüz hareket sırasında sıkışmayı engelleyici emniyet sistemi
3. Acil durumlarda makinenin tüm enerjisini kesmek ve durdurmak için sağ üst köşeye konumlandırılmış acil durdurma butonu



1. Self-Diagnostics provided through the digital display allows easy trouble-shooting with the use of an external hand-held analyzer.
2. Hinged battery steel cover can be easily opened, enhance efficient to supply distilled water or electrolyte.
3. Vertical motor ensures convenience inspection and maintenance of motor and brake, provide much better maintainability than horizontal motor.

Kolay Servis / Serviceability

1. Dijital göstere ve bir el terminali yardımıyla kolay hata tespit olanağı.
2. Menteşeli çelik akü muhafaza kapağı kolay açılabilir, akü su ve elektrolit takviyesi kolayca yapılabilir
3. Dikey motor, yatay olana göre motor ve fren bakımını kolaylaştırır.

Çalışma Kolaylığı / Operability



1. Ergonomik olarak tasarlanmış kumanda kolu makinenin rahat ve kolay kullanımını sağlar.
2. 180° nin üzerindeki kol dönüş açısı ve kompakt gövde yapısı, düşük dönme çapını ve mükemmel manevra kabiliyetini oluşturur.
3. Kumanda kolu dikey pozisyonda iken hız kontrolü devreye girer ve dar alanlarda daha etkili çalışma olanağı sağlar.

1. The ergonomically designed handle ensures smooth and easy controls of all operation. All the operation of lifting and travelling, will be easily achieved by touching the button switches in the handle.
2. More than 180° tiller/handle rotation range, plus compact body, ensure small turning radius and excellent maneuverability.
3. Creep speed control enabled when tiller/handle in vertical position allows the operator to work more efficient in a confined space.

HARİCİ ŞARJ CİHAZI
EXTERNAL CHARGER

TRANSPALET Akülü / POWERED PALLET TRUCK

NL-FEPT 20 E AC

Art.No. 50500041-1

NL-FEPT 20 E AC

Sürüş tipi / Drive unit		Akülü
Kullanım şekli / Operator type		Yaya
Kaldırma kapasitesi / Capacity	(Q)	2000 kg
Yük merkezi / Load center	(C)	600 mm
Yük mesafesi / Load distance	(X)	916 / 982 mm
Tekerlek merkezi / Wheel base	(Y)	1418 mm
Ağırlık (akü dahil) / Service weight (with battery)		535 kg
Aksa binen yük ön/arka (yükülü) / Axle loading front/rear (laden)		955 / 1580 kg
Aksa binen yük ön/arka (yüksüz) / Axle loading front/rear (unladen)		430 / 105 kg
Tekerlek tipi / Tyres		Poliüretan / Polyurethane
Tekerlek ölçüsü (ön) / Tyre size (front)		ø230 x 75 mm
Tekerlek ölçüsü (arka) / Tyre size (rear)		ø 85 x 70 mm
Teker ölçüsü (denge) / Tyre size (balance)		ø 85 x 48 mm
Tekerlek sayısı ön arka / Wheels, number front/rear (x=driven wheels)		1x +2/4
Teker arası mesafe (operatör tarafı) / Tread (operator side)	(b10)	498 mm
Teker arası mesafe (yük tarafı) / Tread (load side)	(b11)	370 mm
Kaldırma yüksekliği / Lift height	(h3)	120 mm
Sürüşte kontrol kolu yüksekliği / Height of tiller arm in operating position, min./max.	(h14)	715 / 1200 mm
Min. Çatal yüksekliği / Fork height lowered	(h13)	85 mm
Makine boyu / Overall length	(l1)	1748 mm
Çatal gövdesine kadarki uzunluk / Length to face of forks	(l2)	621 mm
Makine genişliği / Overall width	(b1 / b2)	710 mm
Çatal ölçüsü / Fork dimensions	(s/e/l)	55x170x1150 mm
Dıştan dışa çatal genişliği / Fork spread min/max.	(b5)	540 mm
Gövde yerden yüksekliği / Ground clearance, centre of wheelbase	(m2)	30 mm
Koridor genişliği (800x1200 palet) uzunlamasına / Aisle width for pallets 800x1200 lengthways	(Ast)	2419 mm
Koridor genişliği (1000x1200 palet) uzunlamasına / Aisle width for pallets 1000x1200 lengthways	(Ast)	2667 mm
Dönme yarıçapı / Turning radius		1619 mm
Yürüyüş hızı (yükli/yüksüz) / Driving speed (with/without load)		5 / 5.5 km/h
Kaldırma hızı (yükli/yüksüz) / Lift speed (with/without load)		0.051 / 0.060 m/sn
İndirme hızı (yükli/yüksüz) / Lowering speed (with/without load)		0.032/0.039 m/sn
Tırmanma kabiliyeti (yükli/yüksüz) / Gradient (with/without load, mit)		8 / 16 %
Fren / Service brake		Elektromanyetik
Yürüyüş motoru / Driving motor		1.1 kW
Kaldırma motoru / Lifting Motor		0.84 kW
Akü / Battery voltage, nominal capacity	(K5)	24 / 210 V/Ah
Akü ağırlığı / Battery weight		190 kg
Sürüş kontrol tipi / Type of drive control		AC
Gürültü seviyesi / Sound level at operator's ear		74 dB(A)

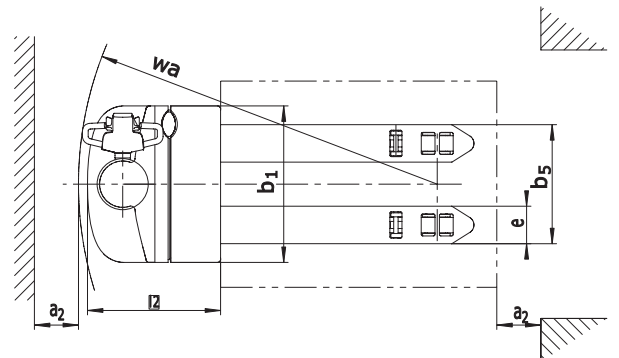
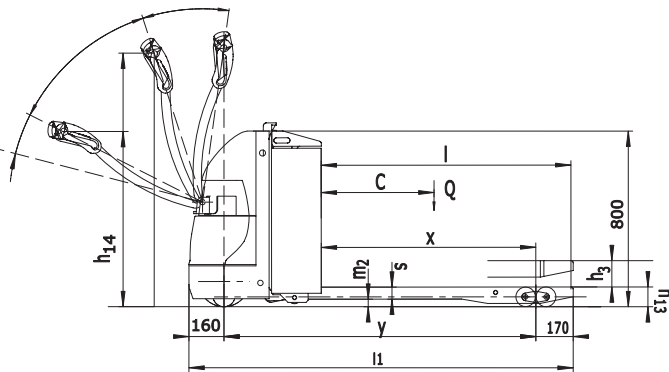

**Performans / Performance**

1. AC sürüş sistemi daha yüksek tepki hızı (8,5km/h), hassas kontrol, daha uzun akü ömrü ve mükemmel performans sağlar.
2. Yeni dizayn fren sistemi daha az enerji tüketimi ve yüksek verimlilik sağlar.
3. Yüksek mukavemete sahip gövde yapısı zor çalışma alanları için uygundur ve daha uzun hizmet ömrü sağlar.
4. Palet taşınmasındaki kusursuz performansı, çalışma verimini artırır.

1. The innovative AC system offers quick response, accurate control, impact structure, excellent performance, longer battery service life.
2. Advanced regenerative braking guarantee low-energy consumption, increasing the efficiency.
3. High-strength frame design, suitable for tough workplaces, ensures longer service life.
4. Excellent performance of getting in and out of empty pallet, greatly increases the operation efficiency.

Çalıştırma Kolaylığı / Emniyet / Operability / Safety

1. Ön ve arka panel arasında parmak sıkışmasını önleyen özel tasarımı panel arka yapısı.
 2. Sürüş platformu ve koruma kolları açık iken yüksek hız (8,5km/h), kapalı iken düşük hız (4km/h) ile operasyon imkanı
 3. Kontrolsüz hareket sırasında sıkışmayı engelleyici emniyet sistemi
 4. Makinenin sağ üst tarafına yerleştirilmiş olan acil durdurma butonunun çekilmesi ile tüm güç kesilmiş olur ve araç durur.
 5. Çift kontrol elektrikli direksiyon sistemi: Hızlı tepki, kolay kumanda, yüksek emniyet.
1. Unique arc board designed on the front frame ensures the clearance between front and rear frames stay constant, avoid the accident of clipping finger.
 2. High speed (8,5km/h) design with guard arm open and stand-on platform in a working position enable the operator to work more efficient in a ride-on mode; Normal speed (4km/h) is available when guard arm closed and stand-on platform at folded position in walkie mode.
 3. Anti-roll back available as standard to prevent uncontrolled travel speed or roll-back on ramps when loading and unloading.
 4. Easy-Touch emergency plug mounted at up-right side on truck frame help operator take immediate action for any emergency happens.
 5. Dual control electric power steering system, quick response, easy control, more safe.

Kolay Servis / Serviceability

1. Tüm kritik ana parçalara kolay ve hızlı erişimi sağlayan vidalı tip üst kapak kullanılmıştır.
 2. Dijital göstere ve harici el terminali yardımıyla kolay sorun tespiti sağlanmıştır.
 3. Bakım maliyetini düşürmek adına mümkün olduğunca çok kolay değiştirilebilir parça kullanılmıştır.
1. One-piece lightweight service access top cover conveniently bolt on and off for easy access to all major and key components, reducing service time when inspection.
 2. Self-Diagnostics provided through the digital display allow easy trouble-shooting with the use of an external hand-held analyzer.
 3. Utilizing as many interchangeable parts as possible, much reduce maintenance cost.

HARİCİ ŞARJ CİHAZI
EXTERNAL CHARGER

- EPS Sistemi : Yüksek verim, düşük enerji tüketimi ve düşük gürültü seviyesi sağlar.
EPS System : High efficiency, low energy consumption, low noise.



Güvenlik / Safety

Güvenli hidrolik sistem tasarımı ile hidrolik hatta kesinti olduğunda mastın aniden düşmesi önlenir. Sıkışma önleyici buton, operatörü sıkışmaktan korur. Acil durdurma butonu, makine kontrolden çıktığında kazayı önlemek için güç kaynağını kesecektir. Çoklu kaldırma sınırı koruması, güvenliği sağlar. Çatal ayar yüksekliğine ulaştığında düşük hıza otomatik geçiş sağlanır. Geri kaymayı önleyen fren, araç kontrolden çıktığında veya rampa üzerinde hareket ettiğinde aracın kaymasını engeller

Safe hydraulic system design prevents mast from falling down abruptly when hydraulic pipeline cuts off. Emergency reverse belly button protects the operator from getting hurt. Emergency disconnecter will cut off power source to avoid accident when truck goes out of control. Multiple lifting limit protection ensures safety. Automatic switch to lower speed when the fork reaches its setting height. Anti-rolling back brake keeps the truck from skidding down when truck is out of control or travelling on ramp.

Bakım / Maintenance

Bakım gerektirmeyen AC yürüyüş motoru ile donatılmıştır. Çalışma saati ve akü göstergesi, operatöre akü şarj ihtiyacını bildirir. Sadece iki civatayı çıkararak arka kapak kolaylıkla açılır, kontrol, bakım ve parça değişiminde operatöre kolaylık sağlanır. Akü bakımı için kolay erişim sağlanmıştır. Dikey motor, muayene ve servisi çok daha kolay hale getirir. Mast ve şase bir birine montajlıdır, bakımı kolaydır. Düşük voltaj kesme ayarı aküleri korur.

C traction motor, maintenance free. - Hour meter and battery indicator remind the operator of battery charging. Easily remove the back cover by only losing two bolts; Access to all key components for inspection, maintenance and replacement. Easy access for battery maintenance. Vertical motor makes the inspection & service much more convenient. Mast and chassis are assembled together, easy for maintenance. - Low voltage cut off setting protects batteries.

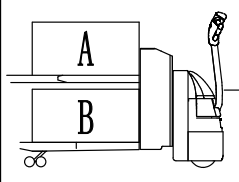
	KALDIRMA YÜKSEKLİĞİ (mm)	KAPASİTE (kg)
	ÇATAL A	630
	ÇATAL B	210
		A+B≤2000

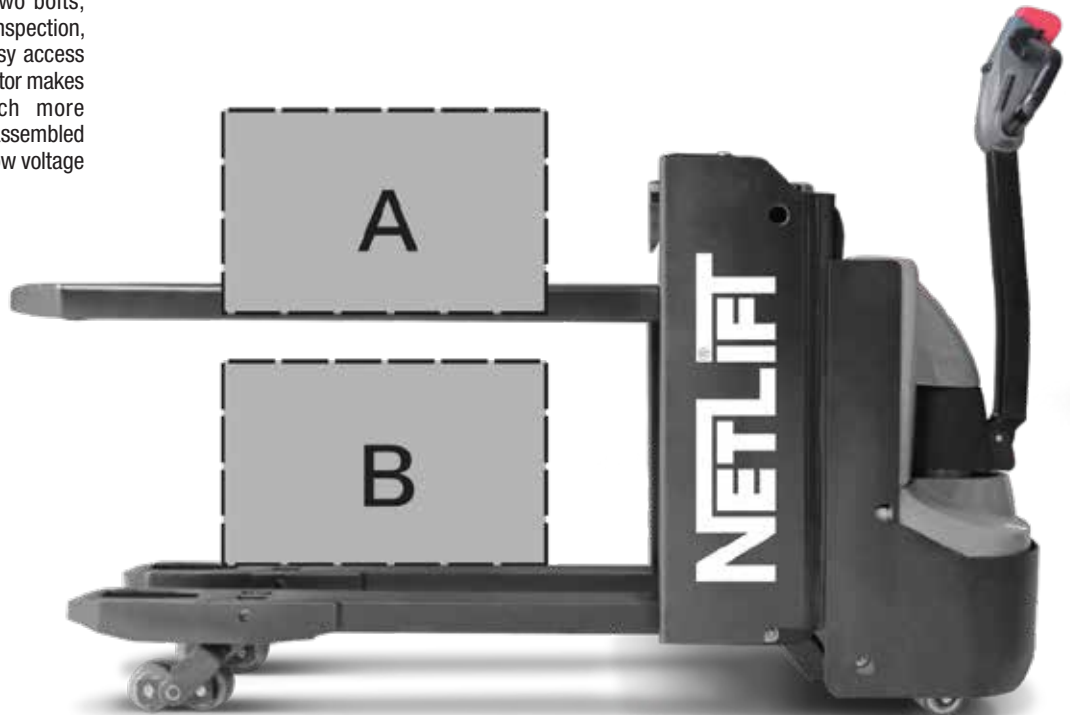
HARİCİ ŞARJ CİHAZI**EXTERNAL CHARGER**

TRANSPALET Akülü / POWERED PALLET TRUCK

NL-FEPT 20 DP

Art.No. 51000130

NL-FEPT 20 DP

Sürüş tipi / Drive unit		Akülü
Kullanım şekli / Operator type		Yaya
Kaldırma kapasitesi / Capacity	(Q)	2000 kg
Yük merkezi / Load center	(C)	600 mm
Yük mesafesi / Load distance	(X)	905 mm
Tekerlek merkezi / Wheel base	(Y)	1441 mm
Ağırlık (akü dahil) / Service weight (with battery)		625 kg
Aksa binen yük ön/arka (yükli) / Axle loading front/rear (laden)		910 / 1715 kg
Aksa binen yük ön/arka (yüksüz) / Axle loading front/rear (unladen)		420 / 205 kg
Tekerlek tipi / Tyres		Poliüretan / Polyurethane
Tekerlek ölçüsü (ön) / Tyre size (front)		ø 230 x 75 mm
Tekerlek ölçüsü (arka) / Tyre size (rear)		ø 85 x 70 mm
Teker ölçüsü (denge) / Tyre size (balance)		ø 85 x 48 mm
Tekerlek sayısı ön arka / Wheels, number front/rear (x=driven wheels)		1x +2 / 4
Teker arası mesafe (yük tarafı) / Track width (loading side)	(b11)	366 mm
Teker arası mesafe (operatör tarafı) / Track width (driving side)	(b10)	498 mm
1. palet kaldırma yüksekliği / Lift height	(h3)	540 mm
2. palet kaldırma yüksekliği / Initian lift	(h5)	120 mm
Sürüşte kontrol kolu yüksekliği / Height of tiller arm in operating position, min./max (h14)		715 / 1200 mm
Min. Çatal yüksekliği / Fork height lowered	(h13)	95 mm
Makine boyu / Overall length	(l1)	1850 mm
Çatal gövdesine kadarki uzunluk / Length to face of forks	(l2)	694 mm
Makine genişliği / Overall width	(b1 / b2)	710 mm
Çatal ölçüsü / Fork dimensions	(s/e/l)	60x190x1150 mm
Dıştan dışa çatal genişliği / Fork spread min/max..	(b5)	560 mm
Gövde yerden yüksekliği / Ground clearance, centre of wheelbase	(m2)	30 mm
Koridor genişliği (1000x1200 palet) uzunlamasına / Aisle width for pallets 1000x1200 lengthways	(Ast)	1913 mm
Koridor genişliği (800x1200 palet) uzunlamasına / Aisle width for pallets 800x1200 lengthways	(Ast)	2113 mm
Dönme yarıçapı / Turning radius		1615 mm
Yürüyüş hızı (yükli/yüksüz) / Driving speed (with/without load)		5 / 5.5 km/h
Kaldırma hızı (yükli/yüksüz) / Lift speed (with/without load)		0.024 / 0.025 m/sn
Mast kaldırma hızı (yükli/yüksüz) / Mast lifting speed (with/without load)		0.071 / 0.121 m/sn
İndirme hızı (destek kolu) (yükli/yüksüz) / Support arm lowering speed (with/without load)		0.050 / 0.032 m/sn
Mast indirme hızı (yükli/yüksüz) / Mast lowering speed (with/without load)		0.13 / 0.1 m/sn
Tırmanma kabiliyeti (yükli/yüksüz) / Gradient (with/without load, mit)		8 / 16 %
Fren / Service brake		Elektromanyetik
Yürüyüş motoru / Driving motor		1.27 kW
Kaldırma motoru / Lifting Motor		0.84 kW
Akü / Battery voltage, nominal capacity	(K5)	24 / 150 V/Ah
Akü ağırlığı / Battery weight		140 kg
Sürüş kontrol tipi / Type of drive control		AC
Gürültü seviyesi / Sound level at operator's ear		74 dB(A)



Standart Ekipmanlar

- Çift palet kaldırma
- Acil durdurma butonu
- Acil durum emniyet butonu
- Yandan akü değişimi
- Akü durum göstergesi
- Geri kaymayı önleyen frenleme
- Güvenli hidrolik sistem
- Ergonomik kumanda kolu
- AC yürüyüş motoru
- Düşük enerji kesme ayarı bataryaları korur.

Standard equipment

- Double pallet lifting
- Emergency stop button
- Emergency chest button
- Side battery change
- Battery status indicator
- Anti-roll back braking
- Safe hydraulic system
- Ergonomic joystick
- AC traction motor
- Low voltage cut-off setting protects batteries.

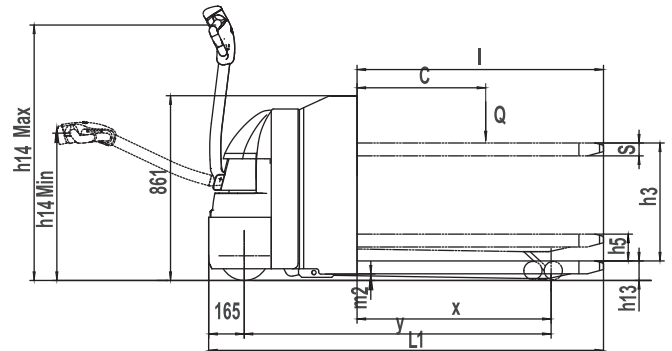
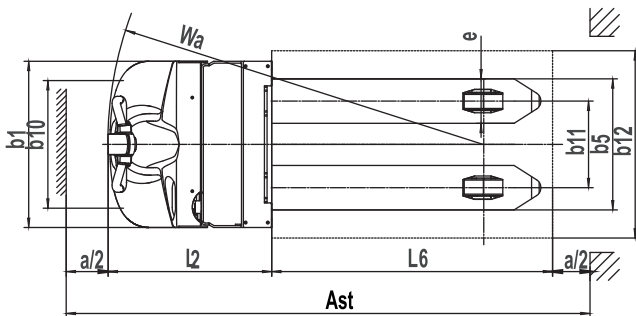

AKÜLÜ TRANSPALET / POWERED PALLET TRUCK

FEPT 20 RAP

Art.No. 505000050-1

NL-FEPT 20 RAP

Kaldırma kapasitesi / Capacity	(Q)	2000 kg
Yük merkezi / Load center	(C)	600 mm
Kullanım şekli / Operator type		Ayakta
Elektrikli direksiyon / Electric power steering	(EPS)	Standart ekipman
Kaldırma yüksekliği / Lift height	(h3)	120 mm
Gövde yerden yüksekliği / Ground clearance	(m2)	30 mm
Max. Çatal kaldırma yüksekliği / Max. fork lifting height	(h3)	120 mm
Standart çatal genişliği / Standart fork width	(b1)	540 mm
Çatal uzunluğu / Fork length	(L)	1150 mm
Çatal kalınlığı / Fork thickness	(S)	55 mm
Çatal genişliği / Fork width	(E)	170 mm
Makine boyu / Overall length	(l1)	2516 mm
Sürüşte kontrol kolu yüksekliği / Height of tiller arm in operating position, min./max	(h5)	1220 mm
Makine genişliği / Overall width	(B)	800 mm
Dönme yarıçapı / Turning radius		2348 mm
Koridor genişliği (800x1200 palet) uzunlamasına / Aisle width for pallets 800x1200 lengthways	(Ast)	3002 mm
Koridor genişliği (1000x1200 palet) uzunlamasına / Aisle width for pallets 1000x1200 lengthways	(Ast)	3145 mm
Yürüş hızı (yükli/yüksüz) / Driving speed (with/without load)		9 / 12 km/h
Kaldırma hızı (yükli/yüksüz) / Lift speed (with/without load)		0.026 / 0.034 m/sn
İndirme hızı (yükli/yüksüz) / Lowering speed (with/without load)		0.025 / 0.021 m/sn
Tırmanma kabiliyeti (yükli/yüksüz) / Gradient (with/without load)		8 / 13 %
Ağırlık (akü dahil) / Service weight (with battery)		940 kg
Tekerlek tipi / Tyres		Poliüretan
Tekerlek miktarı / Wheel quantity (drive/load)		1x +1/4
Teker ölçüsü (ön) / Size of steering wheel		ø230x90 mm
Teker ölçüsü (arka) / Size of loading wheel	(D1)	ø85x70 mm
Teker ölçüsü (denge) / Tyre size (balance)		ø180x65 mm
Tekerlek merkezi / Wheel base	(Y)	2161 mm
Yürüş motoru / Driving motor		2.5 kW
Kaldırma motoru / Lifting Motor		0.84 kW
Akü / Battery voltage, nominal capacity		24/360 V/Ah

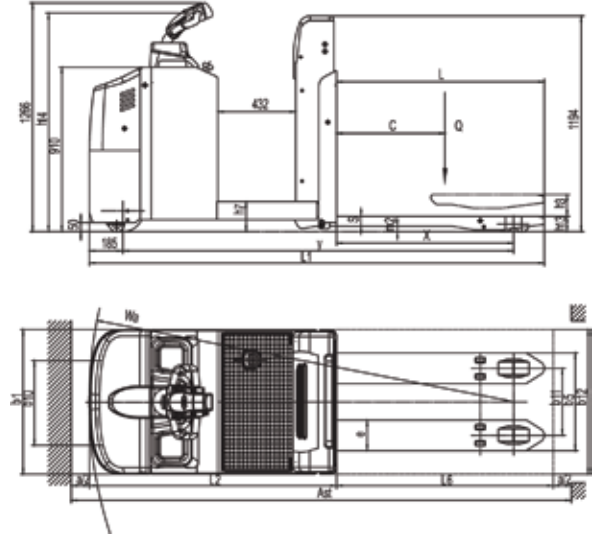

HARİCİ ŞARJ CİHAZI

EXTERNAL CHARGER



EMNİYET PEDALI

DEADMAN SWITCH



GÖSTERGE

(çalışma saati ve akü şarj durumu)

INDICATOR
(operation hour and charge level)



KABİNLİ TRANSPALET / PALLET TRUCK

NL-FEPT 20 C AC

Art.No. 50500043-2

NL-FEPT 20 C AC

Sürüş tipi / Drive unit		Akütlü
Kullanım şekli / Operator type		Ayakta
Kaldırma kapasitesi / Capacity	(Q)	2000 kg
Yük merkezi / Load center	(C)	600 mm
Yük mesafesi / Load distance	(X)	958 mm
Tekerlek merkezi / Wheel base	(Y)	1465 mm
Ağırlık / Service weight		810 kg
Aksa binen yük ön/arka (yükülü) / Axle loading front/rear (laden)		1166 / 1644 mm
Aksa binen yük ön/arka (yüksüz) / Axle loading front/rear (unladen)		630 / 180 mm
Tekerlek tipi / Tyres		Poliüretan
Teker ölçüsü (ön) / Tyre size (driving)		ø 230 x 75 mm
Teker ölçüsü (arka) / Tyre size (loading)		ø 85 x 70 mm
Teker ölçüsü (denge) / Tyre size (balance)		ø 130 x 60 mm
Tekerlek sayısı ön/arka / Wheels, number front/rear (x=driven wheels)		1 x +2/4 mm
Tekerlek iz genişliği ön / Track width, front,	(b10)	510 mm
Tekerlek iz genişliği arka / Track width, rear	(b11)	370 mm
Kaldırma yüksekliği / Lift height	(h3)	125 mm
Sürüşte kontrol kolu yüksekliği / Height of tiller arm in operating position, min./max (h14)		1200 mm
Kapalı yükseklik / Lowered height	(h13)	85 mm
Makine boyu / Overall length	(l1)	2255 mm
Çatal gövdesine kadarki uzunluk / Length to face of forks	(L)	1105 mm
Makine genişliği / Overall width	(b1)	730 mm
Çatal ölçüsü / Fork dimensions	(s/e/l)	55x170x1150 mm
Dıştan dışa çatal genişliği / Fork spread min/max	(b5)	540 mm
Gövde yerden yüksekliği / Ground clearance, centre of wheelbase	(m2)	30 mm
Koridor genişliği (1000x1200 palet) uzunlamasına / Aisle width for pallets 1000x1200 lengthways	(Ast)	2902 mm
Koridor genişliği (800x1200 palet) uzunlamasına / Aisle width for pallets 800x1200 lengthways	(Ast)	2750 mm
Dönme yarıçapı / Turning radius		2102 mm
Yürüyüş hızı (yükülü/yüksüz) / Driving speed (with/without load)		9.0 / 12.0 km/h
Kaldırma hızı (yükülü/yüksüz) / Lift speed (with/without load)		0.051 / 0.060 m/sn
İndirme hızı (yükülü/yüksüz) / Lowering speed (with/without load)		0.032 / 0.039 m/sn
Tırmanma kabiliyeti (yükülü/yüksüz) / Gradient (with/without load, mit)		8 / 16 %
Fren / Service brake		Elektromanyetik
Yürüyüş motoru / Driving motor		2.5 kW
Kaldırma motoru / Lifting Motor		1.0 kW
Akü / Battery voltage, nominal capacity K5		24 / 280 V/Ah
Akü ağırlığı / Battery weight		250 kg
Sürüş kontrol tipi / Type of drive control		AC
Gürültü seviyesi / Sound level at operator's ear		74 dB(A)

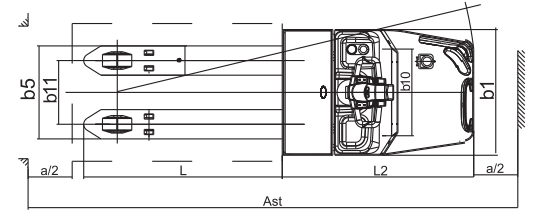
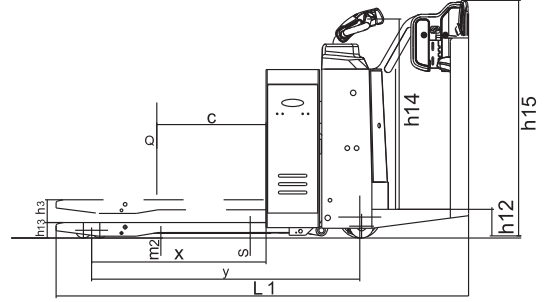

HARİCİ ŞARJ CİHAZI

EXTERNAL CHARGER

- EPS Sistemi : Yüksek verim, düşük enerji tüketimi, kolay ve hızlı manevra imkanı sağlar.
- EPS System : High efficiency, low energy consumption, fast and easy maneuvering



- **MAKSİMUM PERFORMANS**
High performance
- **KONFOR**
Comfort
- **ERGONOMİ**
Ergonomic

Performans / Performance

- 5 yıl test edilmiş EPS sistemi
- AC sürüş sistemi
- Elektromanyetik fren
- Akü göstergesi
- EPS system, tested by the market for 5 years, high reliability.
- Equipped with AC drive system
- Electromagnetic brake
- Battery discharge indicator with hour meter



Konfor / Confort

- Yandan akü değiştirme kolaylığı
- Operatör konforu düşünülerek tasarlanmış kumanda kolu
- Sağ-sol el kullanımına uygun kamanda kolu
- Her hızda optimum yön kontrolü
- Sideway battery design is easy for replacing
- Tiller head designed for Maximum operator comfort
- Controls positioned to allow operation with either hand
- EPS system provides optimum directional control at any speed



Çalışma Alanı / Scope

- Akülü transpaletler, güçlü ve kompakt yapıları sayesinde alışveriş merkezleri, süpermarketler, depolar, antepolar ve benzeri diğer uygulamalarda her sektörde (gıda, tekstil, matbaa gibi) kullanım alanı bulur.
- Electric pallet truck with small appearance and flexible can be used in shopping malls, supermarkets, warehouse, workshop and other places, especially for food, textile, printing and other light industries.



Emniyet / Safety

- İki hareket hızı, koruma kolu kapalıyken yarı siperi ve koruma kolu açıkken tam hız ile operatör güvenliğini artırır
- Sıkışma önleyici emniyet butonu, operatörü yaralanmaya karşı korur.
- Kontrolsüz hareket sırasında acil durdurma butonu ile enerji tamamen kesilebilir.
- Elektromanyetik fren, makine kontrolden çıktığında veya rampa ile giderken makinenin aşağı kaymasını önler.
- Çift izlemeli elektrikli direksiyon, en üst emniyet tasarımı.
- Two travel speed improves operator safety, with half speed when protection arm off and full speed when protection arm on
- Emergency reverse belly button protects the operator from getting hurt.
- Emergency disconnecter will cut off power source to avoid accident when truck goes out of control
- Anti-rolling back brake keeps the truck from skidding down when truck is out of control or travelling on ramp.
- Dual-monitoring power steering, the top safety design (electric steering).

Operasyon / Operation

- Ergonomik kumanda kolu yeni tasarımıyla, tüm düğmeler rahatça ulaşılabilir.
- Katlanabilir platform, sürüş sırasında operatörün rahat etmesini sağlayan titreşimi azaltır.
- Benzersiz süspansiyon sürüş yüzzer sistemi (DFA) tasarımı, işlemi kolay ve konforlu hale getirir.
- Platform katlandığında, daha küçük alanlarda makine düşük hızda çalışabilir.
- Ergonomik kolçak kolay kullanım ve iyi bir oturma imkanı sağlar.
- Elektrikli direksiyon, yumuşak ve rahat kullanım imkanı sağlar(EPS).
- With the new design of ergonomical tiller head, all buttons can be reached conveniently comfortable.
- Foldable platform reduces vibration which make operator comfortable when driving.
- Unique suspension driving floating system (DFA)design, make the operation easy and comfortable.
- When platform is folded, truck can work at low speed in smaller space.
- Ergonomical armrest guarantees easy operation & good resistance.
- Electric power steering, smooth & comfortable (EPS).

Bakım / Maintenance

- AC yürüyüş motoru, bakım gerektirmez
- Çalışma saati ve batarya göstergesi, batarya şarjını operatöre hatırlatır.
- Sadece dört civatayı gevşeterek arka kapağı kolayca çıkarın; Muayene, bakım ve değiştirme için tüm kilit bileşenlere erişim.
- Batarya bakımı için kolay erişim.
- Dikey motor, kontrol ve hizmeti çok daha uygun hale getirir.
- Kontrol sistemi sorun gidermeyi kolaylaştırır.
- Düşük enerji koruma sistemi ile akü korunur.
- AC traction motor, maintenance free
- Hour meter and battery indicator remind the operator of battery charging.
- Easily remove the back cover by only loosening four bolts; Acces to all key componets for inspection, maintenance and replacement.
- Easy access for battery maintenance.
- Vertical motor makes the inspection & service much more convenient.
- Control system allow easy trouble-shooting.
- Low voltage lift cut off design protects batteries.

HARİCİ ŞARJ CİHAZI

EXTERNAL CHARGER



NL-FEPT 25 AC



NL-FEPT 30 AC



TRANSPALET Akülü / POWERED PALLET TRUCK

NL-FEPT 25 AC

NL-FEPT 30 AC

Art.No.50500049-1

NL- FEPT 25 AC

Art.No.50500046-1

NL- FEPT 30 AC

Kaldırma kapasitesi / Capacity	(Q)	2500	3000	kg
Yük merkezi / Load center	(C)	600	600	mm
Kullanım şekli / Operator type		Ayakta	Ayakta	
Elektrikli direksiyon / Electric power steering	(EPS)	Standart ekipman	Standart ekipman	
Kaldırma yüksekliği / Lift height	(h3)	125	110	mm
Gövde yerden yüksekliği / Ground clearance	(h13)	30	85	mm
Max. Çatal kaldırma yüksekliği / Max. fork lifting height	(h)	125	195	mm
Standart çatal genişliği / Standart fork width	(b5)	540	540	mm
Çatal uzunluğu / Fork length	(L)	1150	1150	mm
Çatal kalınlığı / Fork thickness	(S)	55	75	mm
Çatal genişliği / Fork width	(E)	170	175	mm
Makine boyu / Overall length	(l1)	1860	1945	mm
Sürüşte kontrol kolu yüksekliği / Height of tiller arm in operating position, min./max	(h14)	1150 / 1470	1090 / 1360	mm
Gövdeden yük merkezine olan mesafe / Rear body length	(l2)	710	795	mm
Makine genişliği / Overall width	(b1,b2)	730	850	mm
Dönme yarıçapı / Turning radius		1700	1800	mm
Koridor genişliği (800x1200 palet) uzunlamasına / Aisle width for pallets 800x1200 lengthways	(Ast)	2370	2200	mm
Koridor genişliği (1000x1200 palet) uzunlamasına / Aisle width for pallets 1000x1200 lengthways	(Ast)	2522	2150	mm
Yürüyüş hızı (yükli/yüksüz) / Driving speed (with/without load)		5.5 / 6	5 / 6	km/h
Kaldırma hızı (yükli/yüksüz) / Lift speed (with/without load)		0.023 / 0.031	0.029 / 0.033	m/sn
İndirme hızı (yükli/yüksüz) / Lowering speed (with/without load)		0.043 / 0.032	0.023 / 0.018	m/sn
Tırmanma kabiliyeti (yükli/yüksüz) / Gradient (with/without load, mit)		6 / 16	5 / 8	%
Ağırlık (akü dahil) / Service weight (with battery)		690 (210Ah)	860 (210Ah)	kg
Tekerlek tipi / Tyres		Poliüretan	Poliüretan	
Teker ölçüsü (ön) / Tyre size (front)		ø 230 x 75	ø 230 x 75	mm
Teker ölçüsü (arka) / Tyre size (rear)		ø 85 x 70	ø 80 x 70	mm
Teker ölçüsü (denge) / Tyre size (balance)		ø 130 x 60	ø 125 x 50	mm
Tekerlek merkezi / Wheel base	(Y)	1418	1440	mm
Yürüyüş motoru / Driving motor		AC 1.5	AC 1.5	kW
Kaldırma motoru / Lifting Motor		DC 1.0	DC 2.2	kW
Akü / Battery		24 / 210	24 / 210	V/Ah
Sürüş kontrolör tipi / Type of drive controller		ZAPI	Curtis	



Standart ekipmanlar

- EPS(electric power steering)
- AC sürüş motoru, DC kaldırma motoru
- 24 V
- Geri beslemeli fren sistemi
- Fren tipi : Elektromanyetik
- Akü göstergesi
- Kaldırma indirme butonu
- Ergonomik sürüş kolu
- Geri sıkışma koruma swici
- Kornası
- Parmak hareketi ile sürüş kontrolü
- Ağır hizmet çekiş mili
- Standart denge tekeri

Standard equipment

- EPS(electric power steering)
- AC travel motor & DC lifting motor
- 24 Voltage
- Regenerate travel brake
- Brake type: Electromagnetic
- Battery Discharge Indicator, Hour Meter
- Key Switch
- Lift/Lower Buttons in handle
- Ergonomic control handle
- Belly button reversing switch
- Horn
- Thumb control travel function
- Heavy duty pull rod
- Standard stability casters

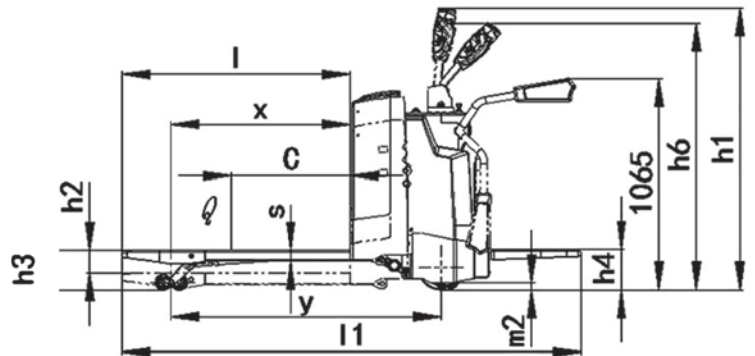
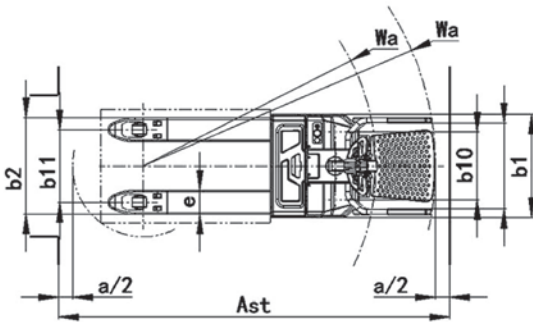

PU TEKERLEKLER / PU WHEELS



Art.No. Y10120006 200 mm



Art.No. Y10120004 180 mm



Art.No. Y10120002 80x70 mm

PU tekerler yumuşak yapısı ile sessiz çalışma olanağı sağlar, iz bırakmaz. Asma katlar ve düzgün zeminler için idealdir. PU wheels provide silent operation with soft structure. It leaves no trace. Ideal for mezzanines and smooth floors

PA TEKERLEKLER / PA WHEELS



Art.No. Y10120005 200 mm



Art.No. Y10120003 180 mm



Art.No. Y10120001 80x70 mm

PA tekerler sert yapısı ile ağır yüklerin kolay hareket etmesini sağlar, kimyasal dayanımı nedeni ile gıda, ilaç, kimya sektörlerinde ağırlıklı olarak kullanım alanı bulur. İz bırakmaz. Düzgün zemin koşullarında kullanılmalıdır. PA wheels provide easy movement for heavy cargos. It's mainly used in food, pharmaceutical and chemical industries due to its chemical resistance. It leaves no trace. Should be used on smooth ground.

DÖKÜM TEKERLEKLER / CAST WHEELS



Art.No. Y10120146 200 mm



Art.No. Y10320004 180 mm



Art.No. Y10120049 80x70 mm

Döküm tekerler ağır hizmet uygulamaları için geliştirilmiştir. Cast wheels are developed for heavy duty applications

LASTİK TEKERLEKLER / RUBBER WHEELS



Art.No. Y10120145 200 mm



Art.No. Y10120374 180 mm

KEÇE TAKIMLARI / SEALKITS



Art.No. Y10110079 DP 25



Art.No. Y10110002 AP 25

BAKIM ÜRÜNLERİ / MAINTENANCE PRODUCTS



Art.No. 52000197 NL-BS 01

Bakım Spreyi /
Maintenance spray



Art.No. 520000100 NL-TS 01

Temizleme Spreyi /
Cleaning spray



Art.No. 52000198 NL-GS 01

Gres Kartuşu /
Grease cartridge



■ **Mini İstif Makineleri**
Mini Stackers

■ **Manuel İstif Makineleri**
Hand Stackers

■ **Yarı Elektrikli İstif Makineleri**
Semi-Electric Stackers

■ **Yaya Kumandalı İstif Makineleri**
Electric Pedestrian Stackers

■ **Elektrikli Denge Ağırlıklı İstif Makineleri**
Counter Weight Semi-Electric Stackers

■ **Akülü Çekiciler**
Electric Towing Tractor

İSTİF MAKİNELERİ
STACKERS

İSTİF MAKİNESİ Mini / PLATFORM STACKER

	NL-MMS 0485	NL-MMS 0412	NL-MMS 0415	
Kaldırma kapasitesi / Capacity	400	400	400	kg
Makine yüksekliği / Max. height (h ₁)	980	1330	1630	mm
Kaldırma yüksekliği / Lifting height (h ₃ +h ₁₃)	850	1200	1500	mm
Min. platform yüks. / Min. platform height (h ₁₃)	200	200	200	mm
Maksimum genişlik / Max. width (b ₁)	590	590	590	mm
Platform uzunluğu / Platform length (p ₁)	650	650	650	mm
Platform genişliği / Platform width (p ₂)	550	550	550	mm
Ön (yön) tekerleği / Rear roller	Ø 150 x 40	Ø 150 x 40	Ø 150 x 40	mm
Arka (yük) tekerleği / Load roller	Ø 150 x 45	Ø 150 x 45	Ø 150 x 45	mm
Ağırlık / Weight	70	76	86	kg

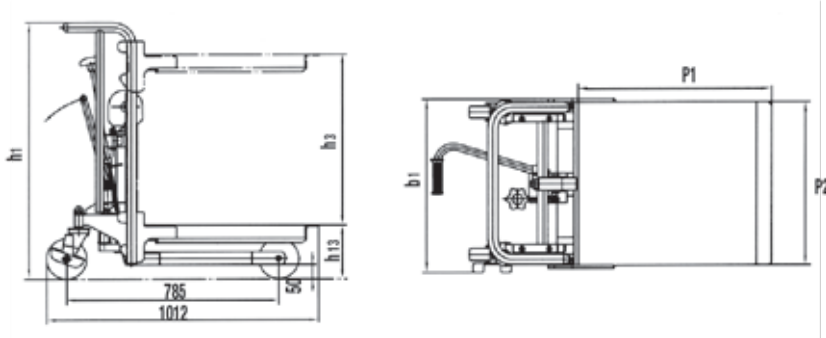

Art.No. 51000001	NL-MMS 0485
Art.No. 51000002	NL-MMS 0412
Art.No. 51000003	NL-MMS 0415

PLATFORMLU



İSTİF MAKİNESİ Mini / PLATFORM STACKER

	NL-MMS 0485 P	NL-MMS 0412 P	NL-MMS 0415 P	
Kaldırma kapasitesi / Capacity	400	400	400	kg
Makine yüksekliği / Max. height (h ₁)	1075	1425	1725	mm
Kaldırma yüksekliği / Lifting height (h ₃ +h ₁₃)	850	1200	1500	mm
Min. platform yüks. / Min. platform height (h ₁₃)	85	85	85	mm
Maksimum genişlik / Max. width (b ₁)	600	600	600	mm
Platform uzunluğu / Platform length (p ₁)	650	650	650	mm
Platform genişliği / Platform width (p ₂)	576	576	576	mm
Çatal ölçüleri / Fork dimensions (s x e)	650 x 10	650 x 10	650 x 10	mm
Ön (yön) tekerleği / Rear roller	Ø 127 x 40	Ø 127 x 40	Ø 127 x 40	mm
Arka (yük) tekerleği / Load roller	Ø 75 x 40	Ø 75 x 40	Ø 75 x 40	mm
Ağırlık / Weight	75	81	91	kg

Art.No. 51000004	NL-MMS 0485 P
Art.No. 51000005	NL-MMS 0412 P
Art.No. 51000006	NL-MMS 0415 P

ÇATALLI ve PLATFORMLU

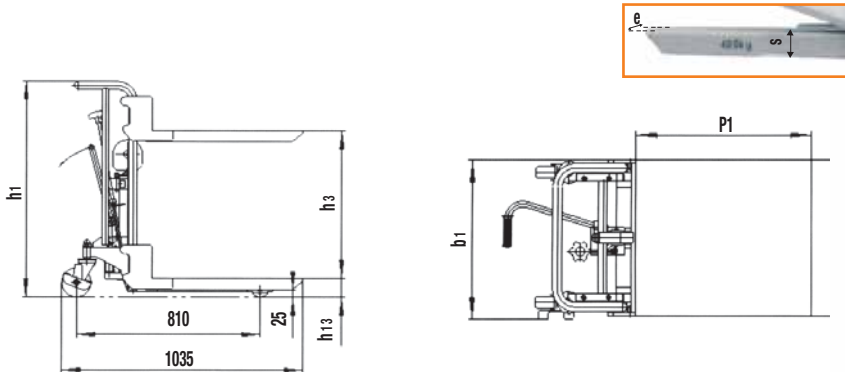

İSTİF MAKİNESİ Mini Akülü / ELECTRIC PLATFORM STACKER

	NL-EMMS 0412	NL-EMMS 0415	NL-EMMS 0412P	NL-EMMS 0415P		
Kaldırma kapasitesi / Capacity	400	400	400	400	kg	
Makine yüksekliği / Max. height	(h ₁)	1330	1630	1425	1725	mm
Kaldırma yüksekliği / Lifting height	(h ₃ + h ₁₃)	1200	1500	1200	1500	mm
Min. platform yüks. / Min. platform height	(h ₁₃)	200	200	85	85	mm
Maksimum genişlik / Max. width	(b1)	590	590	600	600	mm
Platform boyu / Platform length	(p1)	650	650	650	650	mm
Platform genişliği / Platform width	(p2)	550	550	576	576	mm
Ön (yön) tekerleği / Rear roller	Ø 150 x 40	Ø 150 x 40	Ø 127 x 40	Ø 127 x 40	mm	
Arka (yük) tekerleği / Load roller	Ø 150 x 45	Ø 150 x 45	Ø 75 x 40	Ø 75 x 40	mm	
Çatal ölçüleri / Fork dimensions	(s x e)	-	-	650 x 110	650 x 110	mm
Kaldırma hızı (yükli/yüksüz) / Lifting speed (with/without load)	0.80 / 0.185	0.80 / 0.185	0.80 / 0.185	0.80 / 0.185	m/sn	
İndirme hızı (yükli/yüksüz) / Lowering speed (with/without load)	0.75 / 0.115	0.75 / 0.115	0.75 / 0.115	0.75 / 0.115	m/sn	
Akü / Battery	DC12/ 60	DC12/ 60	DC12/ 60	DC12/ 60	V/ Ah	
Motor / Motor	DC12/ 0.7	DC12/ 0.7	DC12/ 0.7	DC12/ 0.7	V/ kW	
Ağırlık / Weight	115	123	120	128	kg	

Art.No. 5100007

NL-EMMS 0412

Art.No. 5100008

NL-EMMS 0415

Art.No. 5100009

NL-EMMS 0412 P

Art.No. 5100010

NL-EMMS 0415 P

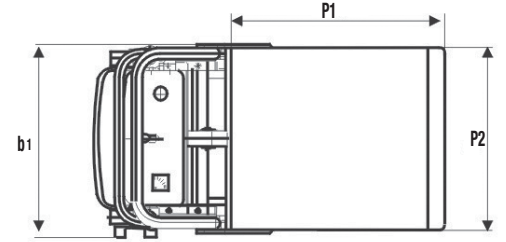
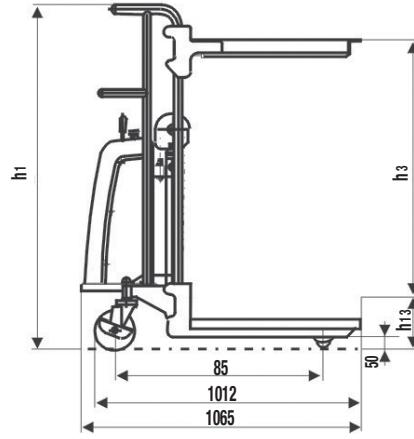

ÇATALLI ve PLATFORMLU

NL-EMMS-P

ERGONOMİK - MANUEL İSTİF ARACI / LATERAL PALLET TILTER

NL-LT 0892

Art.No. 5100012

NL-LT 0892

Kaldırma kapasitesi / Capacity	800	kg
Çatal uzunluğu / Length of fork	1150	mm
Çatal genişliği / Width of fork	150	mm
Dıştan dışa çatal genişliği / Overall fork width	540	mm
Kaldırma yüksekliği / Max. fork height	920	mm
Min. çatal yüksekliği / Min. fork height	88	mm
Çatal eğim derecesi (sağ/sol.) / Tilttable degree (left-right)	20	°
Ön (yön) tekerleği / Rear roller	Ø 160 x 50	mm
Arka (yük) tekerleği / Load roller	Ø 80 x 70	mm
Ağırlık / Weight	210	kg

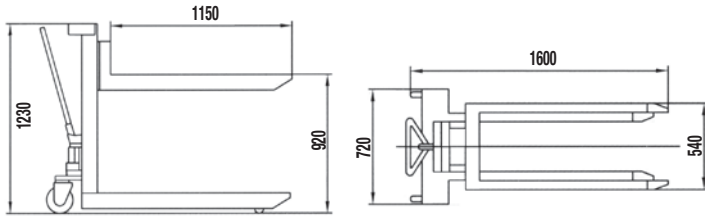

- Kullanıcı yükü zorlanmadan her açıdan alabilir.
- Çatalar sola ve sağa 20° dönebilir.
- Park freni ve ayak koruyucu standarttır.

- Designed to give the user an ergonomically correct position to reach loads easily without the necessary of bending down or stretching up.
- Forks can be tilted up to 20° both left and right sides by thread.
- Supplied as standart with parking brake and foot protectors.



- Açısı ayarlanabilen çatalar.
- Adjustable angle of forks.

3D AÇILI PALET KALDIRICI / PALLET TILTER

NL-LT 10M

NL-LT 10E

Kaldırma kapasitesi / Capacity	1000	1000	kg
Kaldırma yüksekliği / Lifting height (h)	285	285	mm
Min. çatal yüksekliği / Min. fork height (h ₁)	85	85	mm
Çatal boyu / Fork length (l)	800	800	mm
Kol yüksekliği / Handle length (L ₁)	1138	1138	mm
Yük merkezi / Load center (min/ max) (C ₁)	200/ 400	200/ 400	mm
Dıştan dışa çatal genişliği / Overall fork width (b)	560	560	mm
Makine genişliği / Overall width (B)	638	638	mm
Makine uzunluğu / Overall length (L)	1325	1410	mm
Makine yüksekliği / Overall height (yüksektilmiş/alçatılmış, raised/lowered) (H)	950/ 750	950/ 750	mm
Güç ünitesi / Power unit	-	12 / 0.8	V / kW
Ön (yön) tekerleği / Rear roller	Ø 160 x 50	Ø 160 x 50	mm
Arka (yük) tekerleği / Load roller	Ø 80 x 70	Ø 80 x 70	mm
Ağırlık / Weight	178	185	kg

Art.No. 5100013

NL-LT 10M

Art.No. 5100014

NL-LT 10E

- Kullanıcısının daha ergonomik ve doğru kullanımı için en uygun pozisyonu sağlar, yükleme ve kaldırma - indirme işlemleri esnasında gerektiğinden fazla eğilme ihtiyacı bırakmaz
- Kumanda kolu çalışma sahasından uzağa ayarlanıp sabitlenebilmektedir.
- Ayakta ve oturarak kullanımı için uygundur.
- Çatal 90 dereceye kadar eğilebilmekte ve sabitlenebilmektedir.
- Ayak koruma kafesi ve park freni standarttır.
- EN 1757-1 ve EN 1175'e uygundur.
- Designed to give the user an ergonomically correct position to reach loads easily without the necessity of bending down or stretching up.
- Handle can be turned and locked in position away from the work area.
- Applies to both sitting and standing positions.
- Fork can be tilted up to 90°.
- Both are supplied as standard with parking brake and foot protectors.
- Conforms to EN 1757-1 and EN 1175.

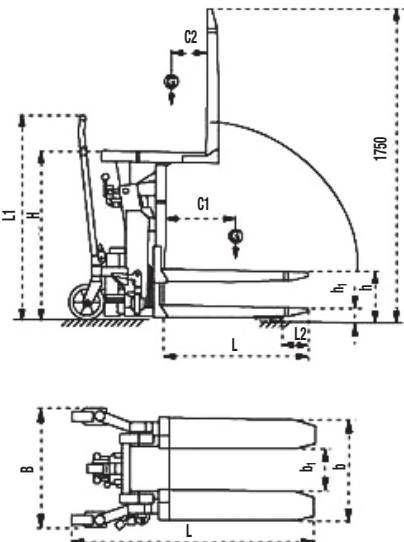

NL-LT 10E



NL-LT 10M



NL-LT 10E

ALÜMİNYUM AKÜLÜ İSTİF MAKİNESİ / ALUMINUM SEMI ELECTRIC STACKER

NL-EMAS 150

NL-EMAS 150A

NL-EMAS 150B

	NL-EMAS 150	NL-EMAS 150A	NL-EMAS 150B	
Kaldırma kapasitesi / Capacity	150	150	150	kg
Ön (yön) tekerleği / Front wheel	Ø 100 x 32	Ø 100 x 32	Ø 100 x 32	mm
Arka (yük) tekerleği / Load roller	Ø 75 x 32	Ø 75 x 32	Ø 75 x 32	mm
Teker sayısı / Number of wheels (ön/arka, front/rear)	4	4	4	
Kapalı mast yüksekliği / Lowered mast height (h ₁)	1958	1958	1958	mm
Kaldırma yüksekliği / Lifting height (h ₃ +h ₁₃)	1550	1550	1550	mm
Min. yükseklik / Lowered height (h ₁₃)	130	115	110	mm
Makine boyu / Overall length (l ₁)	880	865	920	mm
Makine genişliği / Overall width (b ₁)	520	500	500	mm
Çatal uzunluğu / Fork dimensions (l)	460	445	500	mm
Dıştan dışa çatal genişliği / Width overall forks (b ₅)	520	400 (40 x 2)	60	mm
Kaldırma hızı / Lifting speed (yükli/yüksüz, with/without load)	0.067 / 0.082	0.067 / 0.082	0.067 / 0.082	m/sn
İndirme hızı / Lowering speed (yükli/yüksüz, with/without load)	0.096 / 0.089	0.096 / 0.089	0.096 / 0.089	m/sn
Akü / Battery	2 x 12/7	2 x 12/7	2 x 12/7	V/Ah
Ağırlık / Weight	58	56	54	kg

Art.No. 51000112

NL-EMAS 150

Art.No. 51000113

NL-EMAS 150A

Art.No. 51000114

NL-EMAS 150B

- Sanayi işletmelerinde, laboratuvarlarda, hastanelerde, ofislerde veya sipariş uygulamalarında maksimum 150 kg' ye kadar olan yüklerin güç sarfetmeden kolayca kaldırılması ve taşınması için tasarlanmış ideal bir üründür.
- Ideal and handy choice for frequent lifting or for load weight max. 150 kg in industrial, laboratory, hospitals, office or order applications need a compact design and effortless lifting.

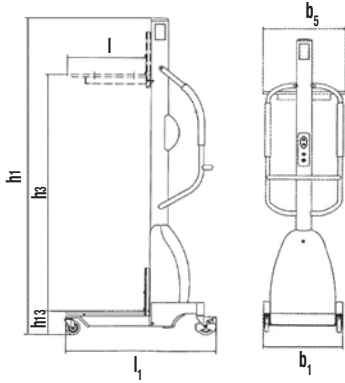

ALÜMİNYUM MANUEL İSTİF MAKİNESİ / HAND STACKER

NL-MAP 181

	NL-MAP 181	
Kaldırma kapasitesi / Capacity	181	kg
Yük merkezi / Load center	305	mm
Kaldırma yüksekliği / Max. fork height	2500	mm
Minimum çatal yüksekliği / Min. fork height	90	mm
Çatal uzunluğu / Fork length	570	mm
Çatal genişliği / Fork width	630	mm
Ağırlık / Weight	60	kg

Art.No. 51000094

NL-MAP 181

- Demonte halde iken az yer kaplar.
- Mastın üzerine monte edilmiş 2 teker sayesinde paket taşıma aracı olarak da kullanılabilir.
- Mastlar hafif alüminyumdan üretilmiştir.
- İndirme-kaldırma sistemi maneldir.
- Güvenli fren sistemi mevcuttur.
- EN 1757:1 standardına uygundur.
- Can fit into smaller spaces when disassembled.
- Equipped with wheels on the mast also allow it to be used as a trolley.
- Light aluminium mast, easy for handling.
- It's operated by manual winch.
- The best brake function with special design is obvious.
- Conforms to EN1757-1

- HAFİF
- FONKSİYONEL



MANUEL İSTİF MAKİNESİ / HAND STACKER

	NL-MS 10-16	NL-MS 15-16	NL-MS 20-16	
Kaldırma kapasitesi / Capacity	1000	1500	2000	kg
Yük merkezi / Load center	400	400	400	mm
Kaldırma yüksekliği / Max. fork height	1600	1600	1600	mm
Minimum çatal yüksekliği / Lowered fork height	90	90	90	mm
Dıştan dışa çatal genişliği / Fork width	300 ~ 820	300 ~ 820	300 ~ 820	mm
Çatal uzunluğu / Fork length	1150	1150	1150	mm
Makine boyu / Overall length	1500	1500	1500	mm
Makine kapalı yüksekliği / Overall height	2100	2100	2100	mm
Makine genişliği / Overall width	865	865	865	mm
Ön (yön) tekerleği / Front wheel	Ø 150 x 42	Ø 150 x 42	Ø 150 x 42	mm
Arka (yük) tekerleği / Rear roller	Ø 74 x 70	Ø 74 x 70	Ø 74 x 70	mm
Ağırlık / Weight	250	260	285	kg



Art.No. 51000023	NL-MS 10-16
Art.No. 51000024	NL-MS 15-16
Art.No. 51000025	NL-MS 20-16



MANUEL İSTİF MAKİNESİ / HAND STACKER

	NL-MS 10-25	NL-MS 10-30	
Kaldırma kapasitesi / Capacity	1000	1000	kg
Yük merkezi / Load center	400	400	mm
Kaldırma yüksekliği / Max. fork height	2500	3000	mm
Minimum çatal yüksekliği / Lowered fork height	90	90	mm
Dıştan dışa çatal genişliği / Overall fork width	300 ~ 820	300 ~ 820	mm
Çatal uzunluğu / Fork length	1150	1150	mm
Makine boyu / Overall length	1500	1500	mm
Makine kapalı yüksekliği / Overall height	1810	2060	mm
Makine genişliği / Overall width	865	865	mm
Ön (yön) tekerleği / Front wheel	Ø 150 x 42	Ø 150 x 42	mm
Arka (yük) tekerleği / Rear roller	Ø 74 x 70	Ø 74 x 70	mm
Ağırlık / Weight	355	370	kg

Art.No. 51000026	NL-MS 10-25
Art.No. 51000027	NL-MS 10-30



MANUEL İSTİF MAKİNESİ / HAND STACKER

NL-MS 1025A

NL-MS 1030A

Kaldırma kapasitesi / Capacity	1000	1000	kg
Yük merkezi / Load center	600	600	mm
Kaldırma yüksekliği / Lifting height	2500	3000	mm
Minimum çatal yüksekliği / Lowered fork height	75	75	mm
Çatal uzunluğu / Fork length	915	915	mm
Minimum dönme yarıçapı / Min. turning radius	1650	1650	mm
Dıştan dışa ayak genişliği / Outer width of legs	1080-1360	1080-1360	mm
İçten içe ayak genişliği / Inner width of legs	960-1240	960-1240	mm
Dıştan dışa çatal genişliği / Overall fork width	210-800	210-800	mm
İçten içe çatal genişliği / Inner width of forks	10-600	10-600	mm
Kaldırma hızı (yükü,) / Lifting speed (with load)	≥16	≥16	mm/sn
İndirme hızı / Lowering speed	Ayarlanabilir / Adjustable		
Makine boyu / Overall length	1480	1480	mm
Makine genişliği / Overall width	1080-1360	1080-1360	mm
Makine kapalı yüksekliği / Overall height	1770	2020	mm
Ön (yön) teker ölçüsü / Outer dia. of the front wheel	Ø 80 x 70	Ø 80 x 70	mm
Arka (yük) teker ölçüsü / Outer dia. of the rear wheel	Ø 150 x 50	Ø 150 x 50	mm
Ağırlık / Weight	360	385	kg

- Her konumdan paleti kavrayabilen tasarım
- Düşük yükseklikteki ve geniş paletler için dizayn edilmiş özel çatalar
- Can lift pallets in different positions.
- Special designed to lift low high and/or extra-width pallets.

Art.No. 51000028

NL-MS 1025A

Art.No. 51000029

NL-MS 1030A

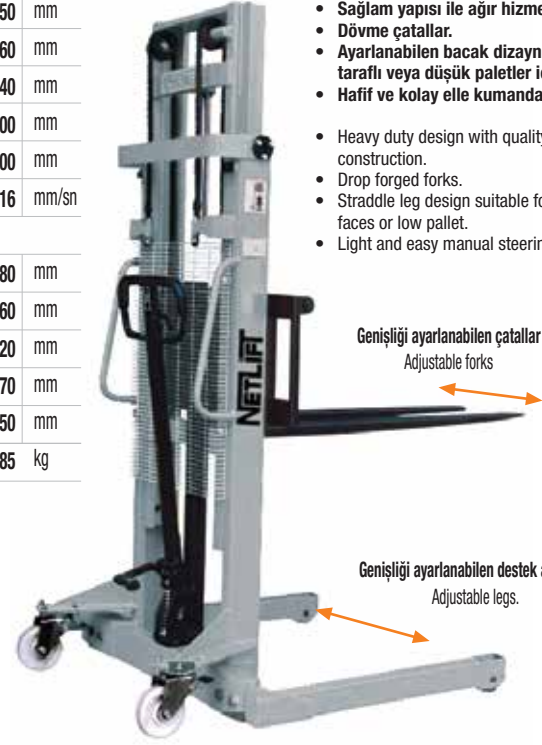

- Sağlam yapısı ile ağır hizmet tasarımı.
- Dövme çatalar.
- Ayarlanabilen bacak dizaynıyla iki taraflı veya düşük paletler için uygun.
- Hafif ve kolay elle kumanda sistemi.
- Heavy duty design with quality mast construction.
- Drop forged forks.
- Straddle leg design suitable for two faces or low pallet.
- Light and easy manual steering system.

YARI ELEKTRİKLİ İSTİF MAKİNESİ / SEMI-ELECTRIC STACKER

NL-DYC 0830

Kaldırma Kapasitesi / Capacity	800	kg
Kaldırma yüksekliği / Max. fork height	3000	mm
Min. çatal yüksekliği / Min. fork height	85	mm
Makine kapalı yüksekliği / Overall height	2055	mm
Çatal ölçüsü / Size of fork	160 x 60	mm
Çatal uzunluğu / Length of fork	1150	mm
Dıştan dışa çatal genişliği / Overall fork width	550	mm
Dönme yarıçapı / Turn radius (Wa)	1260	mm
Ön (yön) tekerleği / Front wheel	Ø 150 x 45	mm
Arka (yük) tekerleği / Rear roller	Ø 74 x 70	mm
Akü / Battery	12/ 150	V/Ah
Kaldırma motoru / Lifting motor power	1.5	kW
Ağırlık (akü dahil) / Service weight (with battery)	466	kg

Art.No. 51000030

NL-DYC 0830



YARI ELEKTRİKLİ İSTİF MAKİNESİ / SEMI-ELECTRIC STACKER

NL-JDYC 10-16

Art.No. 51000031

NL-JDYC 10-16

Kaldırma kapasitesi / Capacity	1000	kg
Yük merkezi / Load center	400	mm
Kaldırma yüksekliği / Lifting height	1600	mm
Çatal uzunluğu / Fork length	1000	mm
Dıştan dışa çatal genişliği / Overall fork width	310-660	mm
Dönme yarıçapı / Turning radius	1350	mm
Kaldırma motoru / Lifting motor	DC 12/ 1.5	V/kW
Akü / Battery	12/ 100	V/Ah
Şarj cihazı / Charger	12/ 15	V/Ah
Makine boyu / Overall length	1500	mm
Makine genişliği / Overall width	850	mm
Makine kapalı yüksekliği / Overall height (lowered)	2000	mm
Ağırlık (akü dahil) / Service weight (with battery)	272	kg

- Ayarlanabilir çatal genişliği
- Adjustable fork width



YARI ELEKTRİKLİ İSTİF MAKİNESİ / SEMI-ELECTRIC STACKER

NL-DYC 10-25A

NL-DYC 10-30A

Art.No. 51000032

NL-DYC 10-25A

Art.No. 51000033

NL-DYC 10-30A

Kaldırma kapasitesi / Capacity	1000	1000	kg
Yük merkezi / Load center	500	600	mm
Kaldırma yüksekliği / Lifting height	2500	3000	mm
Çatal uzunluğu / Fork length	915	915	mm
Dönme yarıçapı / Turning radius	1455	1455	mm
Dıştan dışa ayak genişliği / Outer width of legs	1080-1360	1080-1360	mm
İçten içe ayak genişliği / Inner width of legs	960-1240	960-1240	mm
Dıştan dışa çatal genişliği / Overall fork width	210-800	210-800	mm
İçten içe çatal genişliği / Inner width of forks	10-600	10-600	mm
Kaldırma hızı (yükü / (yük)süz) / Max. Lifting speed (with / without load)	0.078/ 0.150	0.078/ 0.150	m/s
İndirme hızı (yükü / (yük)süz) / Lowering speed (with / without load)	0.103/ 0.100	0.103/ 0.100	m/s
Motor / Motor	12/ 1.6	12/ 1.6	V/kW
Akü / Battery	12/ 120	12/ 120	V/Ah
Makine boyu / Overall length	1550	1550	mm
Makine genişliği / Overall width	1080-1360	1080-1360	mm
Makine kapalı yüksekliği / Overall height (lowered)	1770	2020	mm
Ön (yön) tekerleği / Front wheel	Ø 180 x 50	Ø 180 x 50	mm
Arka (yük) tekerleği / Rear roller	Ø 102 x 50	Ø 102 x 50	mm
Ağırlık (akü dahil) / Service weight (with battery)	450	490	kg

- EN 1757-1 e uygundur.
- Sağlam konstrüksiyonuyla güçlü hizmet tasarımı.
- Dövme çatalar.
- Ayarlanabilen bacak dizaynıyla iki tarafı veya düşük paletler için uygun.
- Hafif ve kolay elle kumanda sistemi.

- Conforms to EN1757-1
- Heavy duty design with quality mast construction.
- Drop forged forks.
- Straddle leg design suitable for two faces or low pallet.
- Light and easy manual steering system.
- High quality trouble free power pack.

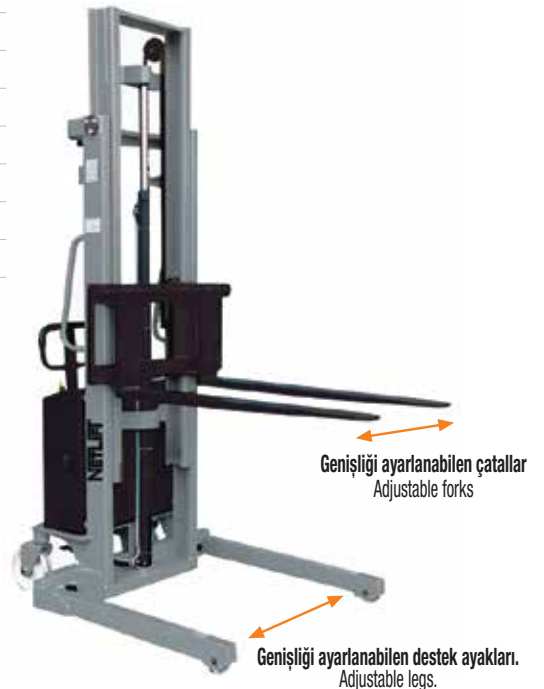

Farklı kaldırma yüksekliklerindeki kapasiteler /

Residual Capacity at different lifting height

Yükseklik / Lifting height mm	Asıl kapasite / Actual Capacity kg
1500	1000
2500	800
3000	600
Yük merkezi / Load centre mm	600

YARI ELEKTRİKLİ İSTİF MAKİNESİ / SEMI-ELECTRIC STACKER

NL-DYC 10-25 NL-DYC 10-30

Art.No. 51000034

NL-DYC 10-25

Art.No. 51000035

NL-DYC 10-30

Kaldırma kapasitesi / Capacity	1000	1000	kg
Yük merkezi / Load center	400	400	mm
Min. çatal yüksekliği / Min. fork height	85	85	mm
Kaldırma çatal yüksekliği / Max. fork height	2500	3000	mm
Makine kapalı yüksekliği / Overall height	1830	2080	mm
Çatal ölçüsü / Size of fork	60 x 160 x 1150	60 x 160 x 1150	mm
Dıştan dışa çatal genişliği / Overall fork width	300-850	300-850	mm
Dönme yarıçapı / Turning radius	1350	1350	mm
Ön (yön) tekerleği / Front wheel	Ø 180 x 50	Ø 180 x 50	mm
Arka (yük) tekerleği / Rear roller	Ø 74 x 70	Ø 74 x 70	mm
Akü / Battery	12/ 150	12/ 150	V/Ah
Kaldırma motoru / Lifting motor	12 / 1.6	12 / 1.6	V / kW
Ağırlık (akü dahil) / Service weight (with battery)	375	395	kg

Farklı kaldırma yüksekliklerindeki kapasiteler /

Residual Capacity at different lifting height

Yükseklik / Lifting height mm	Asıl kapasite / Actual Capacity kg
1500	1000
2500	800
3000	600
Yük merkezi / Load centre mm	400

Genişliği ayarlanabilen çatallar
Adjustable forks



YARI ELEKTRİKLİ İSTİF MAKİNESİ /

SEMI-ELECTRIC STACKER

DYC 10-16 DYC 15-16 DYC 15-20 DYC 15-25 DYC 15-30 DYC 15-35 DYC 20-16 DYC 20-20

Kaldırma kapasitesi / Capacity	1000	1500	1500	1500	1500	1500	2000	2000	kg
Kaldırma yüksekliği / Lifting height	1600	1600	2000	2500	3000	3500	1600	2000	mm
Çatal uzunluğu / Fork length (L)	1150	1150	1150	1150	1150	1150	1150	1150	mm
Dıştan dışa çatal genişliği / Overall fork width(E)	300 ~ 850								mm
Yük merkezi / Load center (C)	400	400	400	400	400	400	400	400	mm
Dönme yarıçapı / Min. turning radius (R)	1350	1350	1350	1350	1450	1450	1350	1350	mm
Kaldırma motoru / Lifting motor	12/ 1.5 ~ 1.6								V/kW
Akü / Battery	12/ 120 ~ 150								V/Ah
Şarj cihazı / Charger	12/ 15								V/Ah
Makine boyu / Overall length (A)	1670	1670	1660	1660	1660	1660	1670	1660	mm
Makine genişliği / Overall width (B)	865	865	865	865	930	930	865	865	mm
Makine kapalı yüksekliği / Overall height (H1)	2060	2060	1580	1830	2080	2330	2060	1580	mm
Ağırlık (akü dahil) / Service weight (with battery)	340	362	448	470	492	515	388	460	kg

Art.No. 51000095

NL-DYC 10-16

Art.No. 51000036

NL-DYC 15-16

Art.No. 51500037

NL-DYC 15-20

Art.No. 51000038

NL-DYC 15-25

Art.No. 51500039

NL-DYC 15-30

Art.No. 51000040

NL-DYC 15-35

Art.No. 51500041

NL-DYC 20-16

Art.No. 51000042

NL-DYC 20-20

Farklı kaldırma yüksekliklerindeki kapasiteler

Residual Capacity at different lifting height

Yükseklik / Lifting height mm	Asıl kapasite / Actual Capacity kg
1600	1500
2000	1200
2500	1000
3000	800
3500	800
Yük merkezi / Load centre mm	400

Yükseklik / Lifting height mm	Asıl kapasite / Actual Capacity kg
1600	2000
2000	1500
Yük merkezi / Load centre mm	400

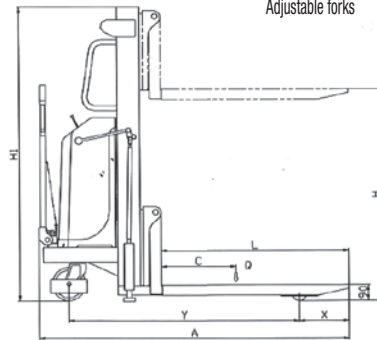
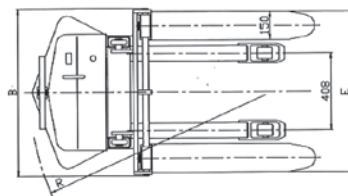

Genişliği ayarlanabilen çatalar
Adjustable forks





- Yüksek performanslı ve bakım gerektirmeyen AC sistemi
- Powerful high quality AC drive unit ensures high performance and low maintenance.
- Opsiyonel EPS - Elektronik kumanda kontrol sistemi
- Optional EPS - Electric steering system.
- Ergonomik CAN-BUS kontrolü sağ ve sol el kullanımına uygun operatör kolu
- Ergonomic CAN-BUS tiller, for both left-handed and right handed operators.



- Kontak anahtarı, acil durdurma butonu ve akü durum göstergesi
- Key-switch, emergency switch and battery indicator.



- Streç film, döküman vb. malzemelerin konulabileceği saklama alanı.
- Diverse storage areas for stretch foils, documents or clipboards, etc.



- Yüksek performanslı, DIN normlarına ve uzun kullanıma uygun akü
- High performanc 3PzS (4Pzs) DIN-standard battery cells for long operations.



- Opsiyonel katlanabilir sürüş platformu ve koruma kolları.
- Optional foldable platform with protective arms.

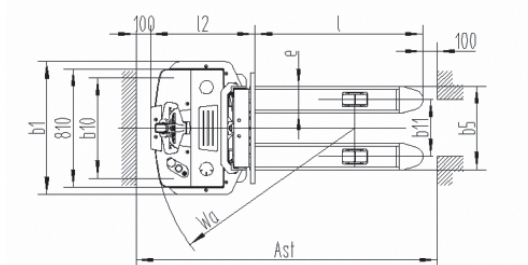
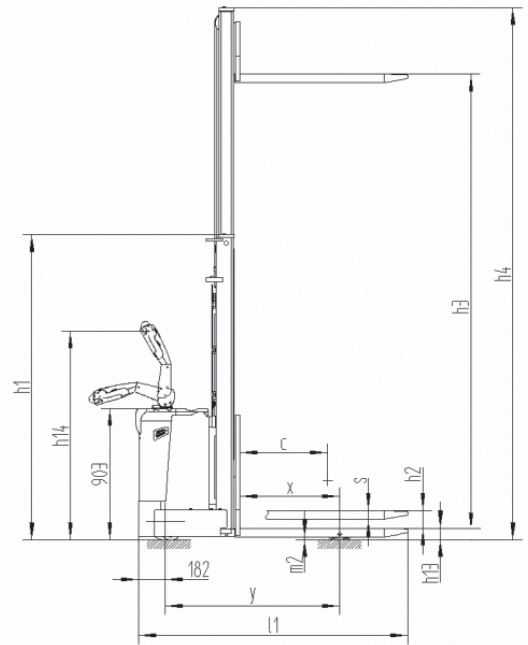

YAYA KUMANDALI İSTİF MAKİNESİ / ELECTRIC PEDESTRIAN STACKER

	PSE 1229 AC	PSE 1232 AC	PSE 1232 FFL AC	PSE 1236 AC	
Güç / Power	Akülü	Akülü	Akülü	Akülü	
Kullanım şekli / Type of operation	Yaya	Yaya	Yaya	Yaya	
Kaldırma kapasitesi / Capacity	1200	1200	1200	1200	kg
Yük merkezi / Load center distance (c)	600	600	600	600	mm
Yük mesafesi / Load distance centre of drive axle fork (x)	684	684	684	684	mm
Tekerlek mesafesi / Wheel base (y)	1196	1196	1196	1196	mm
Ağırlık (akü dahil) / Service weight (with battery)	960	960	960	960	kg
Aksa binen yük ön/arka (yükülü) / Axle loading, laden front/rear	830 / 1330	830 / 1330	830 / 1330	830 / 1330	kg
Aksa binen yük ön/arka (yüksüz) / Axle loading, unladen front/rear	730 / 230	730 / 230	730 / 230	730 / 230	kg
Teker türü (ön/arka) / Wheel type (front/rear)	Poliüretan	Poliüretan	Poliüretan	Poliüretan	
Teker ölçüsü (yürüyüş) / Tire size front	Ø 252 x 88	Ø 252 x 88	Ø 252 x 88	Ø 252 x 88	mm
Teker ölçüsü (yük) / Tire size rear	Ø 80 x 70	Ø 80 x 70	Ø 80 x 70	Ø 80 x 70	mm
Teker ölçüleri (denge) / Additional wheels (dimensions)	Ø 150 x 54	Ø 150 x 54	Ø 150 x 54	Ø 150 x 54	mm
Teker sayısı (yön/yük) / Number of wheels (drive/load)	1x+2/4	1x+2/4	1x+2/4	1x+2/4	
Teker arası mesafe (ön) / Track width (front) (b ₁₀)	686	686	686	686	mm
Teker arası mesafe (arka) / Track width (rear) (b ₁₁)	390	390	390	390	mm
Mast kapalı yükseklik / Lowered mast height (h ₁)	1946	2096	2096	2296	mm
Serbest kaldırma / Free lift (h ₂)	120	120	1634	120	mm
Kaldırma yüksekliği / Lifting height (h ₃ + h ₁₃)	2900	3200	3200	3600	mm
Mast açık yükseklik / Extended mast height (h ₄)	3296	3596	3581	3996	mm
Sürüşte kontrol kolu yüksekliği / Height of tiller in drive position (min./max.) (h ₁₄)	985 / 1420	985 / 1420	985 / 1420	985 / 1420	mm
Minimum çatal yüksekliği / Fork height lowered (h ₁₃)	81	81	81	81	mm
Makine uzunluğu / Overall length (l ₁)	1846	1846	1846	1846	mm
Çatal gövdesine kadarki uzunluk / Length to face of forks (l ₂)	695	695	695	695	mm
Makine genişliği / Overall width (b ₁)	910	910	910	910	mm
Çatal ölçüsü / Size of fork (s/ e/ l)	60x180x1150	60x180x1150	60x180x1150	60x180x1150	mm
Dıştan dışa çatal genişliği / Overall fork width (b ₅)	570	570	570	570	mm
Yerden yükseklik (gövde) / Ground clearance, centre of wheelbase (m ₂)	26	26	26	26	mm
Koridor genişliği (1000x1200 mm palet) çapraz / Aisle width for pallets 1000x1200 crossway (Ast)	2320	2320	2320	2320	mm
Koridor genişliği (800x1200 mm palet) uzunlamasına / Aisle width for pallets 800x1200 lengthways (Ast)	2215	2215	2215	2215	mm
Dönme yarıçapı / Turning radius (Wa)	1400	1400	1400	1400	mm
Yürüyüş hızı (yükülü/yüksüz) / Traveling speed (with/without load)	6.0 / 6.0	6.0 / 6.0	6.0 / 6.0	6.0 / 6.0	km/h
Kaldırma hızı (yükülü/yüksüz) / Lifting speed (with/without load)	0.105 / 0.15	0.105 / 0.15	0.105 / 0.15	0.105 / 0.15	m/sn
İndirme hızı (yükülü/yüksüz) / Lowering speed (with/without load)	0.13 / 0.11	0.13 / 0.11	0.13 / 0.11	0.13 / 0.11	m/sn
Tırmanma kabiliyeti (yükülü/yüksüz) / Gradient (with/without load)	6 / 12	6 / 12	6 / 12	6 / 12	%
Fren / Service brake	Elektromanyetik	Elektromanyetik	Elektromanyetik	Elektromanyetik	
Yürüyüş motoru / Driving motor	1.3	1.3	1.3	1.3	kW
Kaldırma Motoru / Lifting motor	2.2	2.2	2.2	2.2	kW
Akü / Battery	24 / 210	24 / 210	24 / 210	24 / 210	V/Ah
Akü ağırlığı / Battery weight	200	200	200	200	kg
Sürüş kontrol tipi / Type of drive control	AC Speed Kontrol	AC Speed Kontrol	AC Speed Kontrol	AC Speed Kontrol	
Gürültü seviyesi / Sound level at driver's ear acc. to EN 12053	<70	<70	<70	<70	dB (A)

* Özel kaldırma yükseklikleri için satış temsilcimiz ile irtibata geçiniz.

Art.No. 51000055-1 **NL-PSE 1229 AC**

Art.No. 51000075-1 **NL-PSE 1232 AC**

Art.No. 51000076-1 **NL-PSE 1232 FFL AC**

Art.No. 51000060-1 **NL-PSE 1236 AC**

FFL: Serbest Kaldırma/ FFL: Full free lift

Farklı kaldırma yüksekliklerindeki kapasiteler / Residual Capacity at different lifting height

NL-PSE 1229 AC

Yükseklik / Lifting height mm	Asıl kapasite / Actual Capacity kg	
2900	800	500
2500	1200	800
2000	1200	1200
Yük merkezi / Load centre (mm)	600	700

NL-PSE 1232 AC

Yükseklik / Lifting height mm	Asıl kapasite / Actual Capacity kg	
3200	800	500
2500	1200	800
2000	1200	1200
Yük merkezi / Load centre (mm)	600	700

NL-PSE 1232 FFL AC

Yükseklik / Lifting height mm	Asıl kapasite / Actual Capacity kg	
3200	800	500
2500	1200	800
2000	1200	1200
Yük merkezi / Load centre (mm)	600	700

NL-PSE 1236 AC

Yükseklik / Lifting height mm	Asıl kapasite / Actual Capacity kg	
3600	600	400
3200	800	500
2500	1200	800
2000	1200	1200
Yük merkezi / Load centre (mm)	600	700

YAYA KUMANDALI İSTİF MAKİNESİ ÇİFT PALETLİ / ELECTRIK STACKER - INITIAL LIFT NL - PSS 1230 DP

Sürüş tipi / Type of drive		Elektrikli	
Kullanım şekli / Type of operation		Ayakta	
Kaldırma kapasitesi / Capacity		1200	kg
Yük merkezi / Load center distance	(c)	600	mm
Tekerlek mesafesi / Wheel base	(y)	1275	mm
Ağırlık (akü dahil) / Service weight (with battery)		940	kg
Tekerlek tipi / Wheel type		Poliüretan	
Tekerlek ölçüsü / Front wheel size		Ø 85 x 70	mm
Yürüyüş teker ölçüsü / Drive wheel size		Ø 230 x 75	mm
Denge teker ölçüsü / Caster wheel size		Ø 130 x 55	mm
Tekerlek sayısı / Wheels quantity		1x 1/4	
Mast kapalı yükseklik / Lowered mast height	(h1)	1970	mm
Makine uzunluğu / Overall length	(l1)	1847	mm
Makine genişliği / Overall width	(b1)	800	mm
Sürüşte kontrol kolu yüksekliği / Height of tiller in drive position (min./max.)	(h14)	715 / 1200	mm
Serbest kaldırma / Free lift	(h2)	100	mm
Mast açık yükseklik / Mast extend height	(h4)	3529	mm
Kaldırma yüksekliği / Lifting height	(h3)	2930	mm
Yerden yükseklik min. / Min. Ground clearance		30	mm
Çatal uzunluğu / Fork length	(l3)	1150	mm
Dıştan dışa çatal genişliği / Overall fork width	(b5)	560	mm
Dönme yarıçapı / Turning radius	(Wa)	1510	mm
Minimum yükseklik / Lowered height of fork	(b6)	95	mm
Çatal kalınlığı / Fork thickness	(s)	60	mm
Çatal genişliği / Fork width	(e)	190	mm
Koridor genişliği (800x1200 mm palet) / Aisle width for pallets 800x1200 lengthways	(Ast)	2350	mm
Koridor genişliği (1000x1200 mm palet) çapraz / Aisle width for pallets 1000x1200 crossway	(Ast)	2378	mm
Yürüyüş hızı (yükli/yüksüz) / Traveling speed (with/without load)		5.0/5.5	km/h
Kaldırma hızı (yükli/yüksüz) / Lifting speed (with/without load)		0.11/0.16	mm/sn
İndirme hızı (yükli/yüksüz) / Lowering speed (with/without load)		0.19/0.18	mm/s
Tırmanma kabiliyeti (yükli/yüksüz) / Gradient (with/without load)		8/16	%
Yürüyüş motoru / Driving motor		1.1	kW
Kaldırma Motoru / Lifting motor		2.2	kW
Akü voltaj / Battery voltage / capacity		24/210	V/Ah
Akü ölçüsü / Battery size		788x180x560	kg
Akü ağırlığı / Battery weight		190	mm
Fren tipi / Brake type		Eletrmanyetik	

	Çift palet / Double pallet	Kaldırma Yüksekliği / Lifting Height (mm)	Kapasite / Capacity (kg)
A	Çatal A / Fork A	1600	1000
B		2000	1000
	Çatal B / Fork B	210	A+B<1200

Standart Ekipmanlar

- Çift palet kaldırma
- Acil durdurma butonu
- Sıkışma önleyici emniyet butonu
- Yandan akü değişimi
- Akü durum göstergesi
- Geri kaymayı önleyen frenleme
- Güvenli hidrolik sistem
- Ergonomik kumanda kolu
- AC çekiş motoru
- Düşük voltaj koruma sistemi

Standard Equipments

- Double pallet handling
- Emergency stop button
- Emergency reverse (anti jamming protection) button
- Side battery loading
- Battery / hour meter
- Anti-rolling back brake system
- Safe hydraulic system
- Ergonomic tiller and controls
- AC traction motor
- Low voltage protection system

ÇİFT PALET TAŞIMA/ DOUBLE PALLET HANDLING

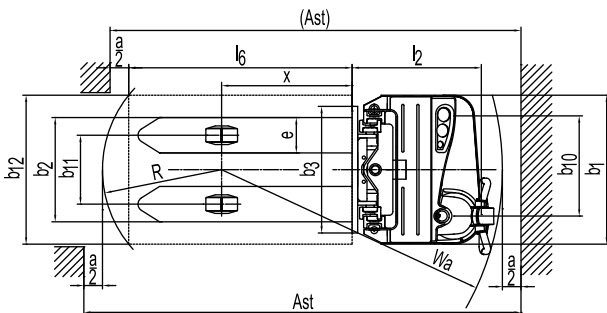

YAYA KUMANDALI İSTİF MAKİNESİ / FULL ELECTRIC STACKER

PSS 1240 E AC FFL PSS 1245 E AC FFL PSS 1248 E AC FFL

Sürüş tipi / Drive unit	Elektrikli	Elektrikli	Elektrikli	
Operatör tipi / Operator type	Yaya	Yaya	Yaya	
Kapasite / Capacity	1200	1200	1200	kg
Yük merkezi / Load centre (Q)	600	600	600	mm
Yük mesafesi / Load distance (c)	688	688	688	mm
Dingil mesafesi / Wheelbase (x)	1225	1225	1225	mm
Ağırlık (akü dahil) / Service weight (with battery) (y)	950	950	950	kg
Aksa binen yük (yükli) ön-arka / Axle loading (laden) front-back	715/1435	715/1435	715/1435	kg
Aksa binen yük (yüksüz) ön-arka / Axle loading (unladen) front-back	645/305	645/305	645/305	kg
Tekerlek tipi / Tyre type	Poliüretan	Poliüretan	Poliüretan	
Tekerlek ölçüsü (sürüş tekeri) / Tyre size (driving wheels)	Ø 230 x 75	Ø 230 x 75	Ø 230 x 75	mm
Tekerlek ölçüsü (yük tekeri) / Tyre size (load wheels)	Ø 85 x 70	Ø 85 x 70	Ø 85 x 70	mm
Tekerlek ölçüsü (denge tekeri) / Tyre size (caster wheels)	Ø 130 x 55	Ø 130 x 55	Ø 130 x 55	mm
Teker sayısı / Wheels number driving	1x +1/4	1x +1/4	1x +1/4	
Kapalı mast yüksekliği / Height , mast lowered (h1)	1822	2022	2122	mm
Serbest kaldırma / Free lift (h2)	1390	1590	1690	mm
Kaldırma yüksekliği / Lift height (h3)	4000	4500	4800	mm
Açık mast yüksekliği / Height (mast extended) (h4)	4460	4960	5260	mm
Minimum yükseklik / Lowered height (h13)	88	88	88	mm
Uzunluk / Overall length (l1)	1826	1826	1826	mm
Gövde uzunluğu / Length to face of forks (l2)	676	676	676	mm
Genişlik / Overall width (b1)	800	800	800	mm
Çatal ölçüsü / Fork dimensions (s/e/l)	60x170x1150	60x170x1150	60x170x1150	mm
Çatal ayna genişliği / Fork carriage width (b3)	680	680	680	mm
Çatallar arası mesafe / Distance between fork-arms (b5)	550	550	550	mm
Yerden yükseklik / Ground clearance (m2)	28	28	28	mm
Çapraz palet genişliği 1000 x 1200 / Aisle width for pallets (Ast)	2333	2333	2333	mm
Uzunlamasına palet genişliği 800 x 1200 / Aisele width for pallets (Ast)	2303	2303	2303	mm
Dönme yarıçapı / Turning radius (Wa)	1463	1463	1463	mm
Sürüş hızı (yükli/yüksüz) / Travel speed (Laden/Unladen)	5.0/5.5	5.0/5.5	5.0/5.5	km/h
Kaldırma hızı (yükli/yüksüz) / Lifting speed (Laden/Unladen)	0.10/0.16	0.10/0.16	0.10/0.16	m/sn
İndirme hızı (yükli/yüksüz) / Lowering speed (Laden/Unladen)	0.19/0.18	0.19/0.18	0.19/0.18	m/sn
Maks. tırmanma / Max. gradeability	8/16	8/16	8/16	%
Fren tipi / Brake type	Elektromanyetik	Elektromanyetik	Elektromanyetik	
Sürüş motoru / Drive motor	1.1	1.1	1.1	kW
Kaldırma motoru / Lift motor	2.2	2.2	2.2	kW
Akü / Battery	24/210	24/230	24/230	V/Ah
Akü ağırlığı / Battery weight	190	190	190	kg
Sürüş tipi / Type of drive unit	AC	AC	AC	
Ses Basıncı / Sound pressure	74	74	74	dB (A)

Art.No.51000068-1

NL-PSS 1240 E AC FFL

Art.No.51000068-2

NL-PSS 1245 E AC FFL

Art.No.51000068-3

NL-PSS 1248 E AC FFL



Standart Ekipmanlar

- AC yürüyüş motoru
- Yan akü yükleme
- ZAPI kontrolör
- Pleksi koruma camı
- Çelik gövde
- Geri kayma önleyici fren
- İkaz lambası

Standard Equipments

- AC drive motor
- Side battery loading
- ZAPI controller
- Plexi protection glass
- Steel body
- Anti-rolling back brake
- Flashing beacon

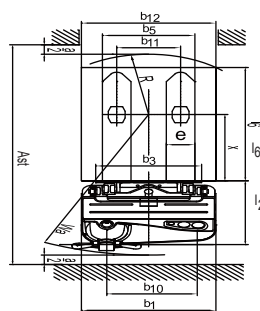
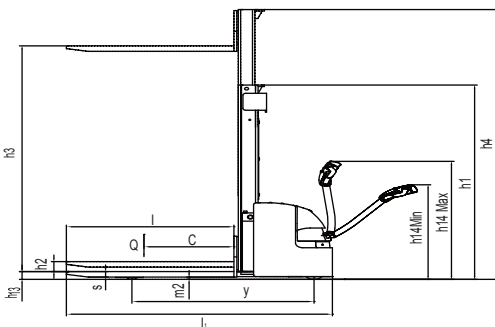
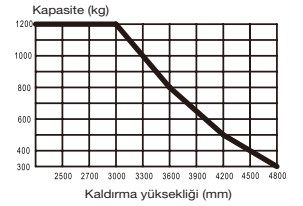



- Yüksek performanslı ve bakım gerektirmeyen AC sistemi
- Powerful high quality AC drive unit ensures high performance and low maintenance.
- Ergonomik CAN-BUS kontrolü sağ ve sol el kullanımına uygun operatör kolu
- Ergonomic CAN-BUS controlled tiller, for both left-handed and right handed operators.



- EPS Sistemi : Yüksek verim, düşük enerji tüketimi ve düşük gürültü seviyesi sağlar.
EPS System : High efficiency, low energy consumption, low noise.



- Kontak anahtarı, acil durdurma butonu ve akü durum göstergesi
- Key-switch, emergency switch and battery indicator.



- Yüksek performanslı, DIN normlarına ve uzun kullanıma uygun akü
- High performanc 3PzS (4Pzs) DIN-standard battery cells for long operations.



- Streç film, döküman vb. malzemelerin konulabileceği saklama alanı.
- Diverse storage areas for stretch foils, documents or clipboards, etc.



- Opsiyonel katlanabilir sürüş platformu ve koruma kolları.
- Optional foldable platform with protective arms.

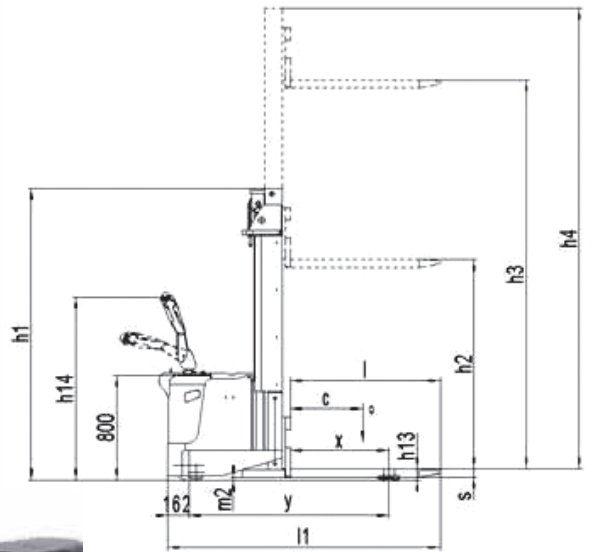
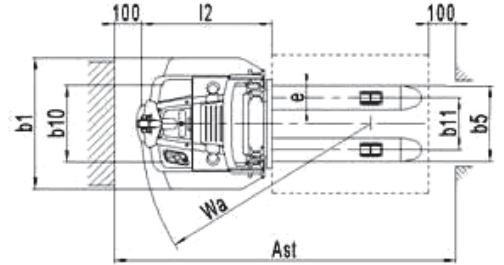

YAYA KUMANDALI İSTİF MAKİNESİ / ELECTRIC PEDESTRIAN STACKER

	PSS 1529 AC	PSS 1534 FFL AC	PSH 1543 FFL AC	PSH 1555 FFL AC	
Güç / Power	Akülü	Akülü	Akülü	Akülü	
Kullanım şekli / Type of operation	Yaya	Yaya	Yaya	Yaya	
Kaldırma kapasitesi / Capacity	1500	1500	1500	1500	kg
Yük merkezi / Load center distance (c)	600	600	600	600	mm
Yük mesafesi / Load distance centre of drive axle fork (x)	684	684	751	751	mm
Tekerlek mesafesi / Wheelbase (y)	1235	1235	1526	1526	mm
Ağırlık (akü dahil) / Service weight (with battery)	1035	1035	1596	1596	kg
Aksa binen yük ön/arka (yükli) / Axle loading, laden front/rear	880 / 1655	880 / 1655	1345 / 1663	1345 / 1663	kg
Aksa binen yük ön/arka (yüksüz) / Axle loading, unladen front/rear	780 / 255	780 / 255	955 / 553	955 / 553	kg
Teker türü (ön/arka) / Wheel type (front/rear)	Poliüretan	Poliüretan	Poliüretan	Poliüretan	
Teker ölçüsü (yürüyüş) / Tire size front	Ø 252 x 88	Ø 252 x 88	Ø 230 x 75	Ø 230 x 75	mm
Teker ölçüsü (yük) / Tire size rear	Ø 80 x 70	Ø 80 x 70	Ø 80 x 70	Ø 80 x 70	mm
Teker ölçüsü (denge) / Additional wheels (dimensions)	Ø 150 x 54	Ø 150 x 54	Ø 124 x 60	Ø 124 x 60	mm
Teker sayısı (yön/yük) / Number of wheels (drive/load)	1x+2/4	1x+2/4	1x+2/4	1x+2/4	mm
Teker arası mesafe (ön) / Track width (front) (b ₁₀)	686	686	750	750	mm
Teker arası mesafe (arka) / Track width (rear) (b ₁₁)	390	390	390	390	mm
Mast kapalı yükseklik / Lowered mast height (h ₁)	1946	1726	1980	2475	mm
Serbest kaldırma / Standard free lift (h ₂)	120	1120	1420	1875	mm
Kaldırma yüksekliği / Lifting height (h ₃ + h ₁₃)	2900	3400	4300	5500	mm
Mast açık yükseklik / Extended mast height (h ₄)	3281	3925	4865	6060	mm
Sürüşte kontrol kolu yüksekliği / Height of tiller in drive position (min./max.) (h ₁₄)	985 / 1420	985 / 1420	945 / 1370	945 / 1370	mm
Minimum çatal yüksekliği / Fork height lowered (h ₁₃)	81	81	85	85	mm
Makine uzunluğu / Overall length (l ₁)	1883	1883	2193	2193	mm
Çatal göv. kadarki uzunluk / Length to face of forks (l ₂)	733	733	1043	1043	mm
Makine genişliği / Overall width (b ₁)	910	910	1000	1000	mm
Çatal ölçüsü / Size of fork (s/ e/ l)	60x180x1150	60x180x1150	60x180x1150	60x180x1150	mm
Dıştan dışa çatal genişliği / Overall fork width (b ₃)	570	570	570	570	mm
Yerden yükseklik (gövde) / Ground clearance, centre of wheelbase (m ₂)	21	21	25	25	mm
Koridor genişliği (1000x1200 mm palet) çapraz / Aisle width for pallets 1000x1200 crossway (Ast)	2360	2360	2660	2660	mm
Koridor genişliği (800x1200 mm palet) uzunlamasına / Aisle width for pallets 800x1200 lengthways (Ast)	2250	2250	2585	2585	mm
Dönme yarıçapı / Turning radius (Wa)	1440	1440	1810	1810	mm
Yürüyüş hızı / Traveling speed (yükli/yüksüz, with/without load)	6.0/6.0	6.0/6.0	6.0/6.0	6.0/6.0	km/h
Kaldırma hızı / Lifting speed (yükli/yüksüz, with/without load)	0.105 / 0.15	0.105 / 0.15	0.141/0.212	0.141/0.212	m/sn
İndirme hızı / Lowering speed (yükli/yüksüz, with/without load)	0.13 / 0.11	0.13 / 0.11	0.196/0.178	0.196/0.178	m/sn
Tırmanma kabiliyeti / Gradient (yükli/yüksüz, with/without load)	6/12	6/12	6/12	6/12	%
Fren / Service brake	Elektromanyetik				
Yürüyüş motoru / Driving motor	1.3	1.3	1.3	1.3	kW
Kaldırma Motoru / Lifting motor	3.0	3.0	3.0	3.0	kW
Akü / Battery voltage, nominal capacity	24 / 210	24 / 210	24 / 350	24 / 350	V/Ah
Akü ağırlık / Battery weight	200	200	288	288	kg
Sürüş kontrol tipi / Type of drive control	AC Speed Kontrol				
Gürültü seviyesi / Sound level	<70	<70	<69	<69	dB (A)

Art.No. 51000067-1	NL-PSS 1529 AC
Art.No. 51000070-1	NL-PSS 1534 FFL AC
Art.No. 51000083-1	NL-PSH 1543 FFL AC
Art.No. 51000086-1	NL-PSH 1555 FFL AC

FFL: Serbest Kaldırma/ FFL: Full free lift

Farklı kaldırma yüksekliklerindeki kapasiteler /
Residual Capacity at different lifting height

NL-PSS 1529 AC

Yükseklik / Lifting height mm	Asıl kapasite / Actual Capacity kg	
2900	1000	700
2200	1500	1000
Yük merkezi / Load centre (mm)	600	700

NL-PSS 1534 FFL AC

Yükseklik / Lifting height mm	Asıl kapasite / Actual Capacity kg	
3400	800	500
2900	1000	700
2200	1500	1000
Yük merkezi / Load centre (mm)	600	700

NL-PSS 1543 FFL AC

Yükseklik / Lifting height mm	Asıl kapasite / Actual Capacity kg	
4300	920	750
4000	1000	800
3400	1100	900
3200	1200	1000
2700	1500	1200
Yük merkezi / Load centre (mm)	600	700

NL-PSS 1555 FFL AC

Yükseklik / Lifting height mm	Asıl kapasite / Actual Capacity kg	
5500	650	500
5000	750	650
4600	850	700
4000	1000	800
3400	1100	900
3200	1200	1000
2700	1500	1200
Yük merkezi / Load centre (mm)	600	700

* Özel kaldırma yükseklikleri için satış temsilcimiz ile irtibata geçiniz.

* Operatör platformu açık ölçüsü

İSTİF MAKİNELERİ
Stackers

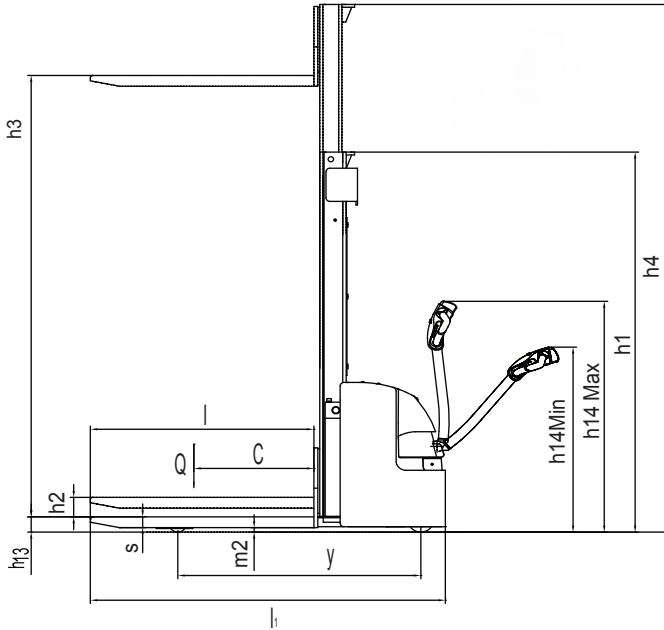
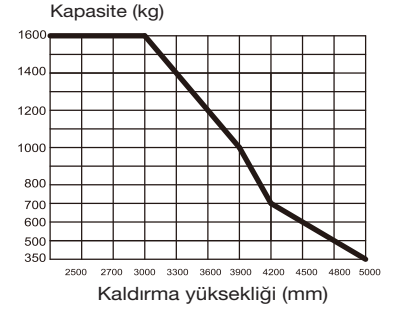
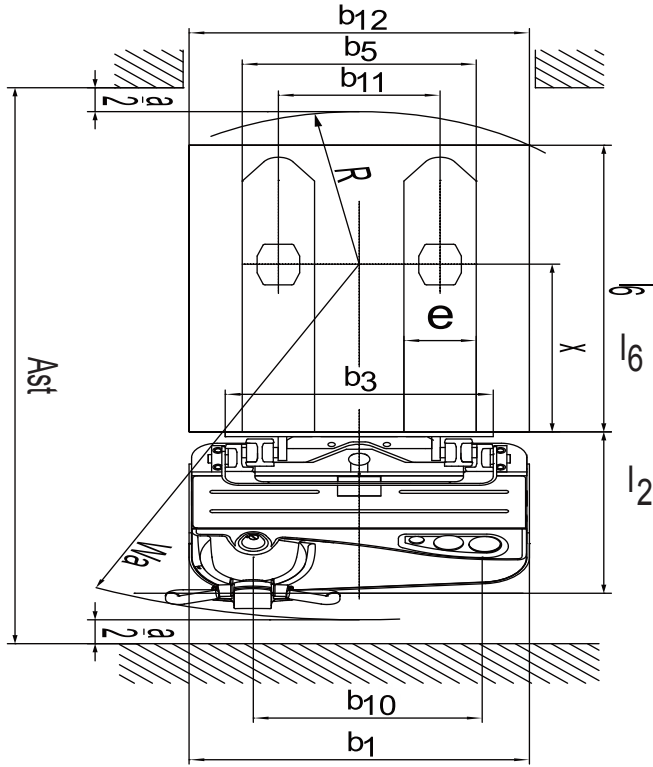

YAYA KUMANDALI İSTİF MAKİNESİ / FULL ELECTRIC STACKER

PSS 1640 E AC FFL

PSS 1645 E AC FFL

PSS 1648 E AC FFL

Art.No. 51000074-6

NL-PSS 1640 E AC FFL

Art.No. 51000074-3

NL-PSS 1645 E AC FFL

Art.No. 51000074-5

NL-PSS 1648 E AC FFL

Sürüş tipi / Drive unit	Elektrikli	Elektrikli	Elektrikli	
Operatör tipi / Operator type	Yaya	Yaya	Yaya	
Kapasite / Capacity	1600	1600	1600	kg
Yük merkezi / Load centre	(Q) 600	600	600	mm
Yük mesafesi / Load distance	(c) 693	693	693	mm
Tekerlek mesafesi / Wheelbase	(x) 1305	1305	1305	mm
Ağırlık (akü dahil) / Service weight (with battery)	(y) 1070	1070	1070	kg
Aksa binen yük (yükli ön-arka) / Axle loading (laden front-back)	780/1890	780/1890	780/1890	kg
Aksa binen yük (yükli ön-arka) / Axle loading (unladen front-back)	730/340	730/340	730/340	kg
Tekerlek tipi / Tyre type	Poliüretan	Poliüretan	Poliüretan	
Teker ölçüsü (yürüyüş) / Tyre size (driving wheel)	Ø 230 x 75	Ø 230 x 75	Ø 230 x 75	mm
Teker ölçüsü (yük) / Tyre size (steering wheel)	Ø 85 x 70	Ø 85 x 70	Ø 85 x 70	mm
Teker ölçüsü (denge) / Tyre size (caster wheel)	Ø 130 x 55	Ø 130 x 55	Ø 130 x 55	mm
Teker sayısı / Wheels number driving	1x +1/4	1x +1/4	1x +1/4	
Kapalı mast yüksekliği / Height , mast lowered	(h1) 1822	2022	2122	mm
Serbest kaldırma / Free lift	(h2) 1390	1590	1690	mm
Kaldırma yüksekliği / Lift height	(h3) 4000	4500	4800	mm
Açık mast yüksekliği / Height (mast extended)	(h4) 4460	4960	5260	mm
Minimum yükseklik / Lowered height	(h13) 88	88	88	mm
Uzunluk / Overall length	(l1) 1940	1940	1940	mm
Gövde uzunluğu / Length to face of forks	(l2) 787	787	787	mm
Genişlik / Overall width	(b1) 800	800	800	mm
Çatal ölçüsü / Fork dimensions	(s/e/l) 60x190x1150	60x190x1150	60x190x1150	mm
Çatal ayna genişliği / Fork carriage width	(b3) 680	680	680	mm
Çatallar arası mesafe / Distance between fork-arms	(b11) 550	550	550	mm
Yerden yükseklik / Ground clearance	(m2) 30	30	30	mm
Koridor genişliği (1000x1200 mm palet) çapraz / Aisle width for pallets 1000x1200 crossway	(Ast) 2465	2465	2465	mm
Koridor genişliği (800x1200 mm palet) çapraz / Aisle width for pallets 800x1200 crossway	(Ast) 2440	2440	2440	mm
Dönme yarıçapı / Turning radius	(Wa) 1589	1589	1589	mm
Sürüş hızı (yükli/yüksüz) / Travel speed (laden/unladen)	5.0/5.5	5.0/5.5	5.0/5.5	km/h
Kaldırma hızı (yükli/yüksüz) / Lifting speed (laden/unladen)	0.13/0.16	0.13/0.16	0.13/0.16	m/sn
İndirme hızı (yükli/yüksüz) / Lowering speed (laden/unladen)	0.22/0.13	0.22/0.13	0.22/0.13	m/sn
Maks. tırmanma / Max. gradeability	8/16	8/16	8/16	%
Fren tipi / Brake type	Elektromanyetik	Elektromanyetik	Elektromanyetik	
Sürüş motoru / Drive motor	1.1	1.1	1.1	kW
Kaldırma motoru / Lift motor	3.0	3.0	3.0	kW
Akü / Battery	24/230	24/230	24/230	V/Ah
Akü ağırlığı / Battery weight	210	210	210	kg
Sürüş tipi / Type of drive unit	AC	AC	AC	
Gürültü seviyesi / Sound level	74	74	74	dB (A)



Standart Ekipmanlar

- AC sürüş motoru
- ZAPI kontrolör
- Plexi koruma camı
- Çelik gövde
- Geri kayma önleyici fren
- Döner uyarı lambası

Standard Equipments

- AC drive motor
- ZAPI controller
- Plexi protection glass
- Steel body
- Anti-rolling back brake
- Flashing beacon

Standart Ekipmanlar

- Sürüş platformu
- Koruma kolları
- EPS (Hafif kumanda kolu)
- AC sürüş motoru
- Acil durum butonu
- Çelik gövde
- Çelik akü kutusu kapağı

Standard Equipments

- Driving platform
- Protective arms
- EPS (elektrik power steering)
- AC drive motor
- Key-switch, emergency
- Steel body
- Steel battery box cover



Katlanabilir sürüş platformu ve koruma kolları
Foldable platform with protective arms



Yüksek performanslı AC ünitesi
High quality performance AC drive

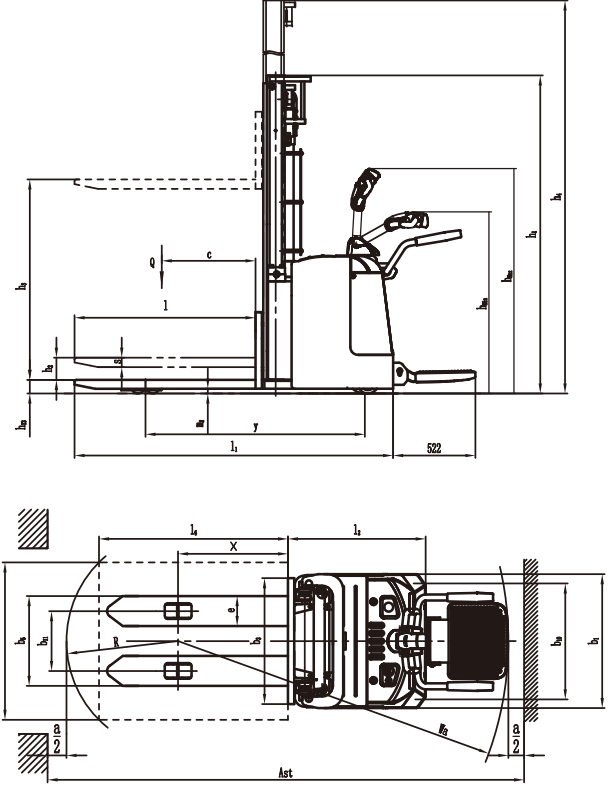

KAPASİTE GRAFİĞİ

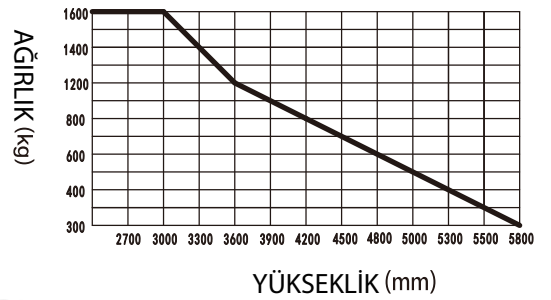

YAN AKÜ YÜKLEME
SIDE BATTERY LOADING

YAYA KUMANDALI İSTİF MAKİNESİ / ELECTRIC PEDESTRIAN STACKER

PSS 1640 AC FFL

PSS 1645 AC FFL

PSS 1648 AC FFL

Güç / Power	Akülü	Akülü	Akülü	
Kullanım şekli / Type of operation	Yaya	Yaya	Yaya	
Kaldırma kapasitesi / Capacity	1600	1600	1600	kg
Yük merkezi / Load center distance (c)	600	600	600	mm
Yük mesafesi / Load distance centre of drive axle fork (x)	693	693	693	mm
Tekerlek mesafesi / Wheelbase (y)	1375	1375	1375	mm
Ağırlık (akü dahil) / Service weight (with battery)	1340	1340	1350	kg
Aksa binen yük ön/arka (yükülü) / Axle loading, laden front/rear	960/1880	960/1880	960/1880	kg
Aksa binen yük ön/arka (yüksüz) / Axle loading, unladen front/rear	860/380	860/380	860/380	kg
Teker türü (ön/arka) / Wheel type (front/rear)	Poliüretan	Poliüretan	Poliüretan	
Teker ölçüsü (yürüyüş) / Tire size (front)	Ø 230 x 75	Ø 230 x 75	Ø 230 x 75	mm
Teker ölçüsü (yük) / Tire size rear	Ø 85 x 70	Ø 85 x 70	Ø 85 x 70	mm
Teker ölçüsü (denge) / Tire size caster	Ø 130 x 55	Ø 130 x 55	Ø 130 x 55	mm
Teker sayısı / Number of wheels (drive/load)	1x+1/4	1x+1/4	1x+1/4	mm
Teker arası mesafe (ön) / Track width (front) (b ₁₀)	574	574	574	mm
Teker arası mesafe (arka) / Track width (rear) (b ₁₁)	380	380	380	mm
Mast kapalı yükseklik / Lowered mast height (h ₁)	1822	2022	2122	mm
Serbest kaldırma / Standard free lift (h ₂)	1390	1590	1690	mm
Kaldırma yüksekliği / Lifting height (h ₃ + h ₁₃)	4000	4500	4800	mm
Mast açık yükseklik / Extended mast height (h ₄)	4460	4960	5260	mm
Sürüşte kontrol kolu yüksekliği / Height of tiller in drive position (min./max.) (h ₁₄)	1150 / 1480	1150 / 1480	1150 / 1480	mm
Minimum çatal yüksekliği / Fork height lowered (h ₁₃)	88	88	88	mm
Makine uzunluğu / Overall length (l ₁)	2030	2030	2030	mm
Çatal gövdesine kadarki uzunluk / Length to face of forks (l ₂)	879	879	879	mm
Makine genişliği / Overall width (b ₁)	850	850	850	mm
Çatal ölçüsü / Fork dimensions (s/ e/ l)	60 x 190 x 1150	60 x 190 x 1150	60 x 190 x 1150	mm
Dıştan dışa çatal genişliği / Overall fork width (b ₅)	570	570	570	mm
Çatal ayna genişliği / Fork carriage width (b ₃)	800	800	800	mm
Koridor genişliği (1000x1200 mm palet) çapraz / Aisle width for pallets 1000x1200 crossway (Ast)	2605	2605	2605	mm
Koridor genişliği (800x1200 mm palet) uzunlamasına / Aisle width for pallets 800x1200 lengthways (Ast)	2575	2575	2575	mm
Dönme yarıçapı / Turning radius (Wa)	1730	1730	1730	mm
Yürüyüş hızı (yükli/yüksüz) / Traveling speed (with/without load)	5.5 / 6.0	5.5 / 6.0	5.5 / 6.0	km/h
Tırmanma kabiliyeti (yükli/yüksüz) / Gradient (with/without load)	8 / 16	8 / 16	8 / 16	%
Fren / Service brake	Elektromanyetik	Elektromanyetik	Elektromanyetik	
Yürüyüş motoru / Driving motor	1.6	1.6	1.6	kW
Kaldırma Motoru / Lifting motor	3.0	3.0	3.0	kW
Akü / Battery voltage, nominal capacity	24 / 280	24 / 280	24 / 280	V/Ah
Akü ağırlık / Battery weight	260	260	260	kg
Sürüş kontrol tipi / Type of drive control	AC Speed Kontrol	AC Speed Kontrol	AC Speed Kontrol	
Gürültü seviyesi / Sound level	74	74	74	dB

* Özel kaldırma yükseklikleri için satış temsilcimiz ile irtibata geçiniz.

Art.No. 51000074-9

NL-PSS 1640 AC FFL

Art.No. 51000074-2

NL-PSS 1645 AC FFL

Art.No. 51000074-4

NL-PSS 1648 AC FFL

Standart Ekipmanlar

- EPS (Elektrikli kumanda kontrol sistemi)
- AC yürüyüş motoru - DC kaldırma motoru
- Yandan akü yükleme
- Yenileyici fren sistemi
- Elektromanyetik fren sistemi
- Akü seviye göstergesi
- Kontak
- Sıkışma önleyici emniyet butonu

Standard equipment

- EPS (electric power steering)
- AC traveling motor & DC lifting motor
- With side-way battery design
- Regenerate travel brake
- Brake type: Electromagnetic
- Battery Discharge Indicator, Hour Meter
- Key Switch
- Belly button reversing switch

Standart Ekipmanlar

- Sürüş platformu
- Koruma kolları
- EPS (Hafif kumanda kolu)
- AC sürüş motoru
- Acil durdurma butonu
- Çelik gövde

Standard Equipments

- Driving platform
- Protective arms
- EPS (electric power steering)
- AC drive motor
- Emergency key-switch
- Steel body



Katlanabilir sürüş platformu ve koruma kolları
Foldable platform with protective arms



Yüksek performanslı AC ünitesi
High quality performance AC drive

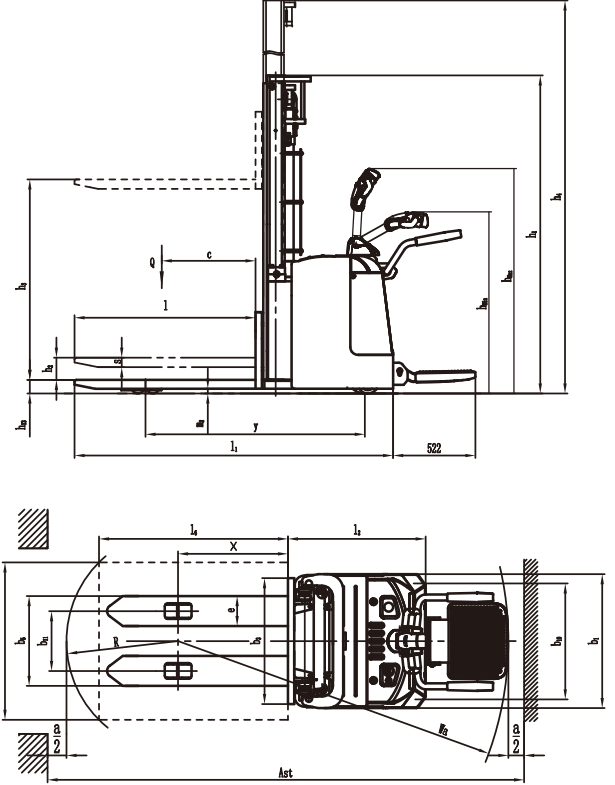

KAPASİTE GRAFİĞİ

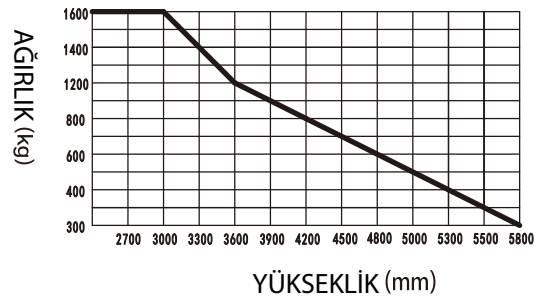

YAN AKÜ YÜKLEME
SIDE BATTERY LOADING

YAYA KUMANDALI İSTİF MAKİNESİ / ELECTRIC PEDESTRIAN STACKER

PSS 1640 AC FFL Li

PSS 1645 AC FFL Li

Güç / Power	Akülü	Akülü	
Kullanım şekli / Type of operation	Yaya	Yaya	
Kaldırma kapasitesi / Capacity	1600	1600	kg
Yük merkezi / Load center distance (c)	600	600	mm
Yük mesafesi / Load distance centre of drive axle fork (x)	693	693	mm
Tekerlek mesafesi / Wheel base (y)	1375	1375	mm
Ağırlık (akü dahil) / Service weight (with battery)	1160	1160	kg
Aksa binen yük ön/arka (yükülü) / Axle loading, laden front/rear	920/1840	920/1840	kg
Aksa binen yük ön/arka (yüksüz) / Axle loading, unladen front/rear	820/340	820/340	kg
Teker türü (ön/arka) / Wheel type (front/rear)	Poliüretan	Poliüretan	
Teker ölçüsü (yürüyüş) / Tire size front	Ø 230 x 75	Ø 230 x 75	mm
Teker ölçüsü (yük) / Tire size rear	Ø 85 x 70	Ø 85 x 70	mm
Teker ölçüsü (denge) / Additional wheels (dimensions)	Ø 130 x 55	Ø 130 x 55	mm
Teker sayısı (yön/yük) / Number of wheels (drive/load)	1x+1/4	1x+1/4	
Teker arası mesafe (ön) / Track width (front) (b ₁₀)	574	574	mm
Teker arası mesafe (arka) / Track width (rear) (b ₁₁)	380	380	mm
Mast kapalı yükseklik / Lowered mast height (h ₁)	1822	2022	mm
Serbest kaldırma / Standard free lift (h ₂)	1390	1590	mm
Kaldırma yüksekliği / Lifting height (h ₃ + h ₁₃)	4000	4500	mm
Mast açık yükseklik / Extended mast height (h ₄)	4460	4960	mm
Sürüşte kontrol kolu yüksekliği / Height of tiller in drive position (min./max.) (h ₁₄)	1150 / 1480	1150 / 1480	mm
Minimum çatal yüksekliği / Fork height lowered (h ₁₃)	88	88	mm
Makine uzunluğu / Overall length (l ₁)	2030	2030	mm
Çatal gövdesine kadarki uzunluk / Length to face of forks (l ₂)	879	879	mm
Makine genişliği / Overall width (b ₁)	850	850	mm
Çatal ölçüsü / Fork dimensions (s/ e/ l)	60 x 190 x 1150	60 x 190 x 1150	mm
Dıştan dışa çatal genişliği / Overall fork width (b ₅)	570	570	mm
Çatal ayna genişliği / Fork carriage width (b ₃)	800	800	mm
Koridor genişliği (1000x1200 mm palet) çapraz / Aisle width for pallets 1000x1200 crossway (Ast)	2605	2605	mm
Koridor genişliği (800x1200 mm palet) uzunlamasına / Aisle width for pallets 800x1200 lengthways (Ast)	2575	2575	mm
Dönme yarıçapı / Turning radius (Wa)	1730	1730	mm
Yürüyüş hızı (yükli/yüksüz) / Traveling speed (with/without load)	5.5 / 6.0	5.5 / 6.0	km/h
Tırmanma kabiliyeti (yükli/yüksüz) / Gradient (with/without load)	8 / 16	8 / 16	%
Fren / Service brake	Elektromanyetik	Elektromanyetik	
Yürüyüş motoru / Driving motor	1.6	1.6	kW
Kaldırma Motoru / Lifting motor	3.0	3.0	kW
Akü / Battery voltage, nominal capacity	24 / 210	24 / 210	V/Ah
Akü ağırlık / Battery weight	60	60	kg
Sürüş kontrol tipi / Type of drive control	AC Speed Kontrol	AC Speed Kontrol	
Gürültü seviyesi / Sound level	74	74	dB(A)

* Özel kaldırma yükseklikleri için satış temsilcimiz ile irtibata geçiniz.

Art.No. 51000087

NL-PSS 1640 AC FFL Li

Art.No. 51000083

NL-PSS 1645 AC FFL Li



Lityum-ion akü avantajları

- + İstenildiği zaman şarj etme imkanı
- + Standart şarj cihazı ile 2,5 saatte tam şarj
- + Bakım gerektirmez.
- + Şarj esnasında gaz çıkışı olmaz.
- + Yedek aküye ihtiyaç duymaz
- + Harici şarj cihazı ile bağımsız akü şarj etme imkanı

Advantages of Lityum-ion battery

- + Charge whenever desired.
- + Fully charging in 2.5 hours with standard charger.
- + No maintenance
- + No gas during charging
- + Continuous operation without spare battery
- + Charging with external charger

Standart Ekipmanlar

- EPS (Elektrikli kumanda kontrol sistemi)
- AC yürüyüş motoru - DC kaldırma motoru
- Yandan akü yükleme
- Yenileyici fren sistemi
- Elektromanyetik fren sistemi
- Akü seviye göstergesi (BDI)
- Kontak anahtarı
- Sıkışma önleyici emniyet butonu

Standard equipment

- EPS (electric power steering)
- AC traveling motor & DC lifting motor
- With side-way battery design
- Regenerat ve travel brake
- Brake type: Electromagnetic
- Battery Indicator, Hour Meter (BDI)
- Key Switch
- Belly button reversing switch



Ergonomi / Ergonomics

- Kumanda kolu operatörün maksimum konforu düşünülerek tasarlanmıştır.
- Her iki el ile de kumanda edilecek şekilde tasarlanmıştır
- EPS sistemi sayesinde her hız seviyesinde optimum yön kontrolü sağlar.
- Tiller head designed for Maximum operator comfort
- Controls positioned to allow operation with either hand
- EPS system provides optimum directional control at any speed



Sürüş sistemi / Total drive system

- AC sürüş sistemi
- Değiştirilmesi kolay encoder
- Fırçasız yenileyici fren sistemi
- Equipped with power AC drive system.
- External encoder, easy for replacement
- Brushless, regenerative brake



Bakım

- AC yürüyüş motoru, bakım gerektirmez.
- Çalışma saati ve batarya göstergesi, batarya şarjını operatöre hatırlatır.
- Yalnızca dört civatayı gevşek arka kapak kolayca çıkarılabilir.
- Muayene, bakım ve değiştirme için tüm kilit bileşenlere erişim sağlar.
- Akü bakımı için kolay erişim imkanı.
- Dikey motor muayene ve servisi çok daha uygun hale getirir.
- Kontrol sistemi sorun giderme kolaylığı sağlar.
- Asansör grubu ve şasi birlikte monte edilir, bakımı kolaydır.
- Düşük voltaj ikaz ayarı bataryaları korur.

Maintenance

- AC traction motor, maintenance free.
- Hour meter and battery indicator remind the operator of battery charging.
- Easily remove the back cover by only loosening four bolts; Access to all key components for inspection, maintenance and replacement.
- Easy access for battery maintenance.
- Vertical motor makes the inspection & service much more convenient.
- Control system allows easy trouble-shooting.
- Mast and chassis are assembled together, easy for maintenance.
- Low voltage cut off setting protects batteries.



- EPS Sistemi : Yüksek verim, düşük enerji tüketimi ve düşük gürültü seviyesi sağlar.
- EPS System : High efficiency, low energy consumption, low noise.

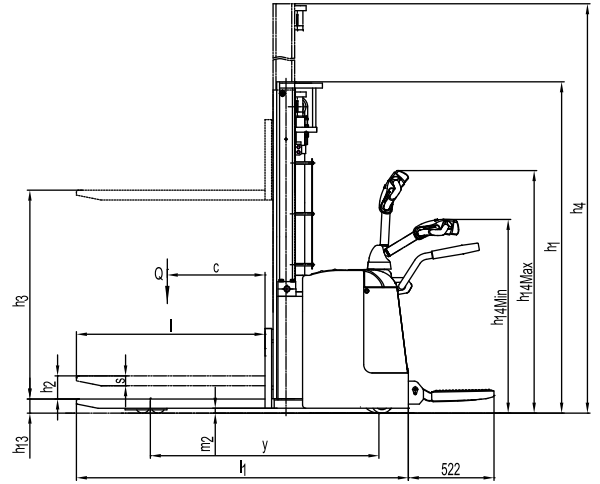

STANDART OLARAK YANDAN AKÜ YÜKLEME
STANDARD SIDE BATTERY LOADING



YAYA KUMANDALI İSTİF MAKİNESİ / ELECTRIC PEDESTRIAN STACKER

PSS 2040 FFL AC

PSS 2050 FFL AC

PSS 2055 FFL AC

		PSS 2040 FFL AC	PSS 2050 FFL AC	PSS 2055 FFL AC	
Kaldırma kapasitesi / Capacity		2000	2000	2000	kg
Yük merkezi / Load center	(c)	600	600	600	mm
Kullanım şekli / Type of operation		Yaya	Yaya	Yaya	
Kaldırma yüksekliği / Optional lifting height	(h3)	4000	5000	5500	mm
Serbest kaldırma yüksekliği / Free lift height	(h2)	1390	1740	1910	mm
Minimum çatal yüksekliği / Fork height lowered	(h13)	88	88	88	mm
Dıştan dışa çatal genişliği / Overall fork width	(b5)	540	540	540	mm
Çatal uzunluğu / Fork length	(l)	1150	1150	1150	mm
Çatal genişliği / Fork width	(e)	190	190	190	mm
Dönme yarıçapı / Turning radius	(Wa)	1738	1738	1738	mm
Min. koridor genişliği / Minimum aisle width	(Ast)	2580 / 2160	2580 / 2160	2580 / 2160	mm
Yerden yükseklik / Ground clearance	(hg)	28	28	28	mm
Yürüyüş hızı (yükli/yüksüz) / Traveling speed (with/without load)		4 / 4,5	4 / 4,5	4 / 4,5	km/h
Kaldırma hızı (yükli/yüksüz) / Lifting speed (with/without load)		0,1 / 0,16	0,13 / 0,16	0,13 / 0,16	m/sn
İndirme hızı (yükli/yüksüz) / Lowering speed (with/without load)		0,33 / 0,23	0,33 / 0,23	0,33 / 0,23	m/sn
Eğim (yükli/yüksüz) / Gradient (with/without load)		6 / 12	6 / 12	6 / 12	%
Ağırlık akü hariç / Service weight without battery		1110	1110	1110	kg
Ağırlık (akü dahil) / Service weight (with battery)		1350	1350	1350	kg
Makine uzunluğu / Overall length	(l1)	2003	2003	2003	mm
Makine genişliği / Overall width	(b1)	850	850	850	mm
Sürüşte kontrol kolu yüksekliği /		1150 / 1480	1150 / 1480	1150 / 1480	mm
Height of tiller in drive position (min./max)	(h14)				
Mast açık yükseklik / Mast extend height	(h4)	4460	5460	5910	mm
Mast kapalı yükseklik / Mast lower height	(h1)	1822	2187	2352	mm
Teker türü (ön/arka) / Wheel type (front/rear)		Poliüretan	Poliüretan	Poliüretan	mm
Teker ölçüsü (yürüyüş) / dimension of driven wheel	(d2)	Ø 230 x 75	Ø 230 x 75	Ø 230 x 75	mm
Teker ölçüleri (yük) / Dimension of load wheel	(d1)	Ø 85 x 70	Ø 85 x 70	Ø 85 x 70	mm
Teker ölçüleri / Dimension of universal wheel	(d)	Ø 130 x 55	Ø 130 x 55	Ø 130 x 55	mm
Tekerlek mesafesi / Wheel base	(y)	1394	1394	1394	mm
Fren tipi / Brake Type		Elektromanyetik	Elektromanyetik	Elektromanyetik	
Yürüyüş motoru / Traveling motor		1.6 AC	1.6 AC	1.6 AC	kW
Kaldırma motoru / Lifting motor		3.0 DC	3.0 DC	3.0 DC	kW
Voltaj / Voltage		24	24	24	V
Akü kapasite / tipi / Battery capacity / type		280 / Endüstri	280 / Endüstri	280 / Endüstri	Ah
Akü kutu ölçüsü / Battery box size (l x w x h)		834x216x630	650x248x548	650x248x548	mm

Art.No.51000018-1

NL-PSS 2040 FFL AC

Art.No.51000019-1

NL-PSS 2050 FFL AC

Art.No.51000021-1

NL-PSS 2055 FFL AC

Standart Ekipmanlar

- EPS (Elektrikli kumanda kontrol sistemi)
- AC yürüyüş motoru -
- DC kaldırma motoru
- Yandan akü yükleme
- Yenileyici fren sistemi
- Elektromanyetik fren sistemi
- Akü seviye göstergesi (BDI)
- Kontak anahtar
- Sıkışma önleyici emniyet butonu

Standard equipment

- EPS(electric power steering)
- AC traveling motor &
- DC lifting motor
- With side-way battery design
- Regenerate travel brake
- Brake type: Electromagnetic
- Battery Discharge Indicator,
- Hour Meter (BDI)
- Key Switch
- Belly button reversing switch

Farklı kaldırma yüksekliklerindeki kapasiteler / Residual Capacity at different lifting height

* Özel kaldırma yükseklikleri için satış temsilcimiz ile irtibata geçiniz.

NL-PSS 2050 FFL AC

Yükseklik / Lifting height mm	Asıl kapasite / Actual Capacity kg
2000	2000
2500	1800
3000	1600
3500	1300
4000	1000
4500	700
5000	500
Yük merkezi / Load centre (mm)	600

NL-PSS 2040 FFL AC

Yükseklik / Lifting height mm	Asıl kapasite / Actual Capacity kg
2000	2000
3000	1600
3300	1400
3600	1200
4000	1000
Yük merkezi / Load centre (mm)	600

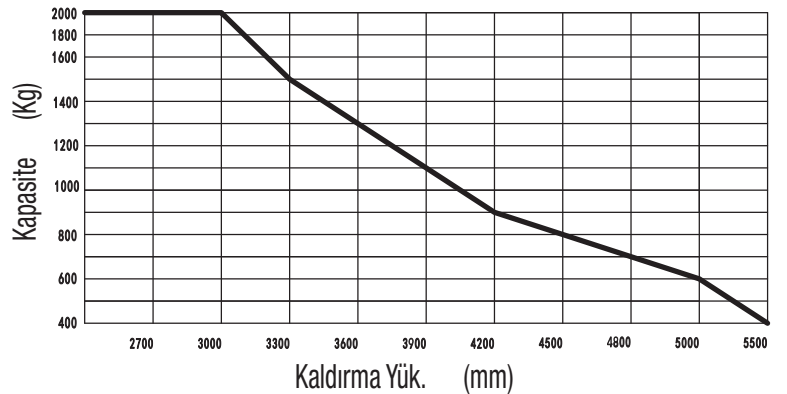

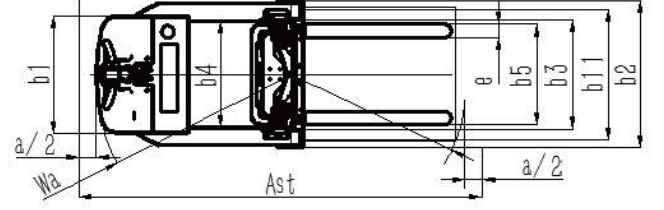
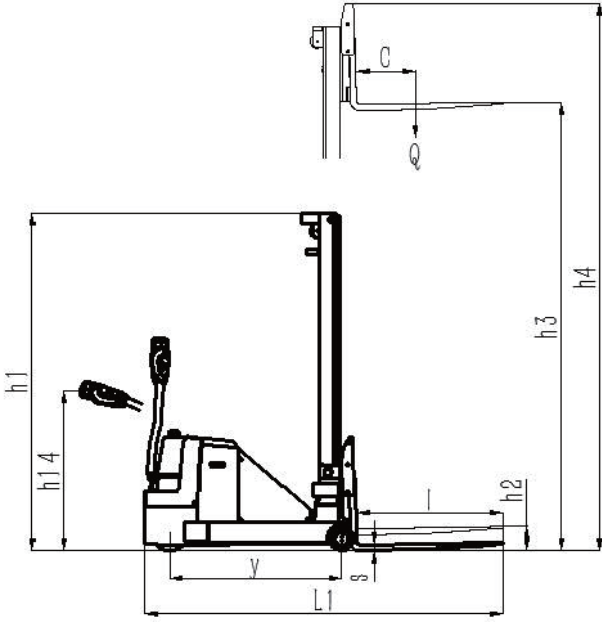

Ergonomik sürüş kolu tasarımı
Ergonomic design of operation handle

DAHİLİ ŞARJ CİHAZI
INTERNAL CHARGER



Genişliği ayarlanabilen çatallar
Adjustable forks

DENGE AĞIRLIKLIL İSTİF MAKİNESİ / ELECTRIC PEDESTRIAN STACKER

PSCB 0820 D

PSCB 0830 D

Güç / Power		Akülü	Akülü	
Kullanım şekli / Type of operation		Yaya	Yaya	
Side shift		-	-	
Çatal tilti / Fork tilt		-	-	
Kaldırma kapasitesi / Capacity		800	800	kg
Kaldırma yüksekliği / Lifting height	(h ₃ + h ₁₃)	2000	3000	mm
Yük merkezi / Load center distance	(c)	500	500	mm
Tekerlek mesafesi / Wheel base	(y)	1150	1150	mm
Ağırlık (akü dahil) / Service weight (with battery)		1140	1180	kg
Aksa binen yük ön/arka (yükülü) / Axle loading, laden front/rear		130/1010	130/1010	kg
Aksa binen yük ön/arka (yüksüz) / Axle loading, unladen front/rear		600/540	600/540	kg
Teker türü (ön/arka) / Wheel type (front/rear)		Poliüretan	Poliüretan	
Teker ölçüsü (yürüyüş) / Tire size front		Ø 140 x 100	Ø 140 x 100	mm
Teker ölçüsü (yük) / Tire size rear		Ø 210 x 70	Ø 210 x 70	mm
Teker sayısı (yön/yük) / Number of wheels (drive/load)		1x/2	1x/2	
Mast kapalı yükseklik / Lowered mast height	(h ₁)	1495	1995	mm
Serbest kaldırma / Standard free lift	(h ₂)	-	-	mm
Mast açık yükseklik / Extended mast height	(h ₄)	2600	3600	mm
Makine uzunluğu / Overall length	(l ₁)	2235	2235	mm
Makine genişliği / Overall width	(b ₁)	700/875	700/875	mm
Çatal ölçüsü / Size of fork	(s/ e/ l)	35/100/1070	35/100/1070	mm
Dıştan dışa çatal genişliği / Overall fork width	(b ₅)	220-600	220-600	mm
Yerden yükseklik (gövde) / Ground clearance, centre of wheelbase (m ₂)		50	50	mm
Koridor genişliği (1000x1200 mm palet) çapraz / Aisle width for pallets 1000x1200 crossway	(Ast)	2740	2740	mm
Koridor genişliği (800x1200 mm palet) uzunlamasına / Aisle width for pallets 800x1200 lengthways	(Ast)	2850	2850	mm
Dönme yarıçapı / Turning radius	(Wa)	1300	1300	mm
Yürüyüş hızı (yükülü/yüksüz) / Traveling speed (with/without load)		3/3.5	3/3.5	km/h
Kaldırma hızı (yükülü/yüksüz) / Lifting speed (with/without load)		0,145/0,215	0,145/0,215	m/sn
İndirme hızı (yükülü/yüksüz) / Lowering speed (with/without load)		0,105	0,105	m/sn
Tırmanma kabiliyeti (yükülü/yüksüz) / Gradient (with/without load)		3/5	3/5	%
Fren / Service brake		Elektromanyetik	Elektromanyetik	
Yürüyüş motoru / Driving motor		0.75	0.75	kW
Kaldırma Motoru / Lifting motor		2	2	kW
Akü / Battery voltage, nominal capacity		24 / 100	24 / 100	V/Ah
Akü ağırlık / Battery weight		65	65	kg

Art.No. 51000141

NL-PSCB 0820 D

Art.No. 51000142

NL-PSCB 0830 D

Standart Ekipmanlar

- DC sürüş motoru
- Bakım gerektirmeyen akü
- Ayarlanabilir çatal
- Dahili Şarj Cihazı
- Acil durum butonu

Standard Equipments

- DC drive motor
- Maintenance-free battery
- Adjustable fork
- Onboard charger
- Key-switch, emergency

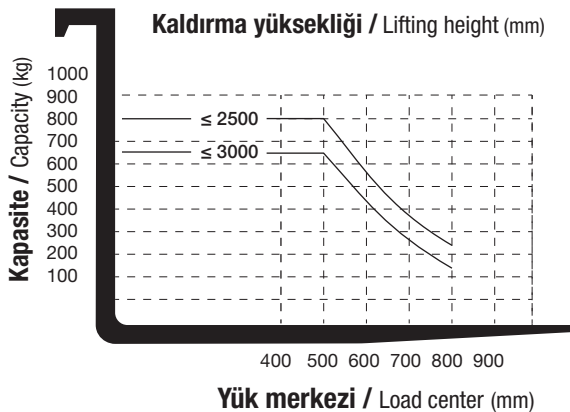



Ergonomik sürüş kolu tasarımı
Ergonomic design of operation handle



Katlanabilir sürüş platformu ve koruma kolları
Foldable platform with protective arms



Genişliği ayarlanabilen çatallar
Adjustable forks

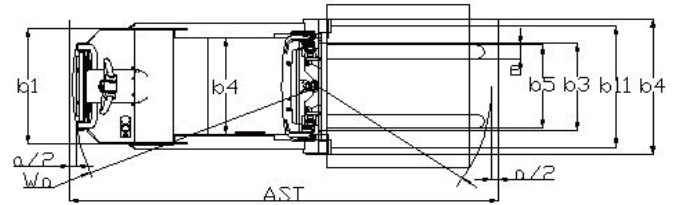
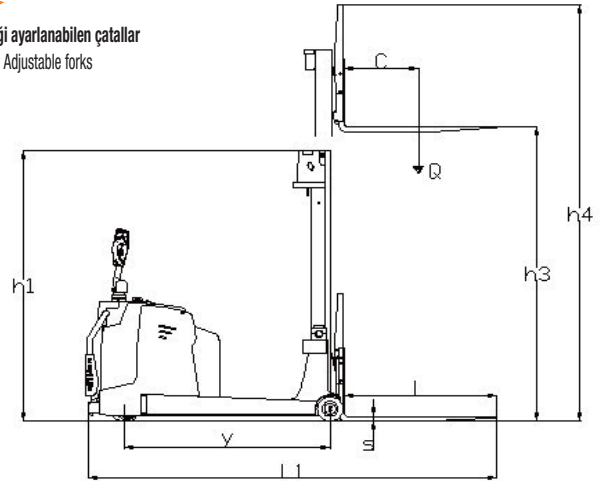

HARİCİ ŞARJ CİHAZI
EXTERNAL CHARGER



YAN AKÜ YÜKLEME
SIDE BATTERY LOADING

DENGE AĞIRLIKLIL İSTİF MAKİNESİ /

ELECTRIC PEDESTRIAN STACKER

PSCB 1625 D PSCB 1635 D PSCB 2025 D PSCB 2035 D PSCB 2045 T PSCB 2050 T PSCB 2055 T

	PSCB 1625 D	PSCB 1635 D	PSCB 2025 D	PSCB 2035 D	PSCB 2045 T	PSCB 2050 T	PSCB 2055 T		
Güç / Power	Aküli	Aküli	Aküli	Aküli	Aküli	Aküli	Aküli	Art.No. 51000143	
Kullanım şekli / Type of operation	Yaya	Yaya	Yaya	Yaya	Yaya	Yaya	Yaya	NL-PSCB 1625 D	
Side shift	-	-	+	+	+	+	+	Art.No. 51000144	
Çatal tilti / Fork tilt	+	+	+	+	+	+	+	NL-PSCB 1635 D	
Kaldırma kapasitesi / Capacity	1600	1600	2000	2000	2000	2000	2000	kg	
Kaldırma yüksekliği / Lifting height	(h ₃ + h ₁₃)	2500	3500	2500	3500	4500	5000	5500	mm
Yük merkezi / Load center distance	(c)	500	500	500	500	500	500	500	mm
Tekerlek mesafesi / Wheel base	(y)	1450	1450	1450	1450	1450	1450	1450	mm
Ağırlık (akü dahil) / Service weight (with battery)		2350	2410	2550	2630	2800	2830	2860	kg
Teker türü (ön/arka) / Wheel type (front/rear)	Poliüretan	Poliüretan	Poliüretan	Poliüretan	Poliüretan	Poliüretan	Poliüretan	Poliüretan	Art.No. 51000146
Teker ölçüsü ön / Tire size front	Ø 230 x 75	Ø 230 x 75	Ø 254 x 100	Ø 254 x 100	Ø 254 x 100	Ø 254 x 100	Ø 254 x 100	Ø 254 x 100	mm
Teker sayısı (yön/yük) / Number of wheels (drive/load)	2/1x+2	2/1x+2	4/1x	4/1x	4/1x	4/1x	4/1x	4/1x	mm
Mast kapalı yükseklik / Lowered mast height	(h ₁)	1760	2260	1750	2250	2100	2266	2432	mm
Serbest kaldırma / Standard free lift	(h ₂)	-	-	-	-	1155	1321	1487	mm
Mast açık yükseklik / Extended mast height	(h ₄)	3400	4400	3435	4435	5435	5935	6435	mm
Makine uzunluğu / Overall length	(l ₁)	2960	2960	2990	2990	2990	2990	2990	mm
Makine genişliği / Overall width	(b ₁ + b ₂)	994	994	900/1090	900/1090	900/1090	900/1090	900/1090	mm
Çatal ölçüsü / Size of fork	(s/ e/ l)	35/100/1070	35/100/1070	40/122/1070	40/122/1070	40/122/1070	40/122/1070	40/122/1070	mm
Dıştan dışa çatal genişliği / Overall fork width	(b ₅)	220/610	220/610	264/732	264/732	264/732	264/732	264/732	mm
Yerden yükseklik (gövde) / Ground clearance, centre of wheelbase	(m ₂)	66	66	80	80	80	80	80	mm
Koridor genişliği (1000x1200 mm palet) çapraz / Aisle width for pallets 1000x1200 crossway	(Ast)	3250	3250	3180	3180	3180	3180	3180	mm
Koridor genişliği (800x1200 mm palet) uzunlamasına / Aisle width for pallets 800x1200 lengthways	(Ast)	3350	3350	3300	3300	3300	3300	3300	mm
Dönme yarıçapı / Turning radius	(Wa)	1820	1820	1750	1750	1750	1750	1750	mm
Yürüyüş hızı (yükli/yüksüz) / Traveling speed (with/without load)		4 / 5.8	4 / 5.8	6/10	6/10	6/10	6/10	6/10	km/h
Kaldırma hızı (yükli/yüksüz) / Lifting speed (with/without load)		0,080/0,110	0,080/0,110	0,100/0,140	0,100/0,140	0,100/0,140	0,100/0,140	0,100/0,140	m/sn
İndirme hızı (yükli/yüksüz) / Lowering speed (with/without load)		0,120/0,140	0,120/0,140	0,100/0,095	0,100/0,095	0,100/0,095	0,100/0,095	0,100/0,095	m/sn
Tırmanma kabiliyeti (yükli/yüksüz) / Gradient (with/without load)		5/8	5/8	6/10	6/10	6/10	6/10	6/10	%
Fren / Service brake	Elektromanyetik / Electromagnetic								
Yürüyüş motoru / Driving motor	1.5	1.5	2.5	2.5	2.5	2.5	2.5	kW	
Kaldırma Motoru / Lifting motor	2	2	3	3	3	3	3	kW	
Akü / Battery voltage, nominal capacity	24/270	24/270	24/270	24/270	24/270	24/270	24/270	V/Ah	
Akü ağırlık / Battery weight	200	200	235	235	235	235	235	kg	

Art.No. 51000143

NL-PSCB 1625 D

Art.No. 51000144

NL-PSCB 1635 D

Art.No. 51000145

NL-PSCB 2025 D

Art.No. 51000146

NL-PSCB 2035 D

Art.No. 51000147

NL-PSCB 2045 T FFL

Art.No. 51000148

NL-PSCB 2050 T FFL

Art.No. 51000149

NL-PSCB 2055 T FFL

Standart Ekipmanlar

- AC sürüş motoru
- EPS (Hafif kumanda kolu)
- Koruma kolları
- Sürüş platformu
- Yan akü yükleme
- Ayarlanabilir çatal
- Harici Şarj Cihazı
- Acil durum butonu

Standard Equipments

- AC drive motor
- EPS (electric power steering)
- Protective arms
- Driving platform
- External charger
- Adjustable fork
- Key-switch, emergency

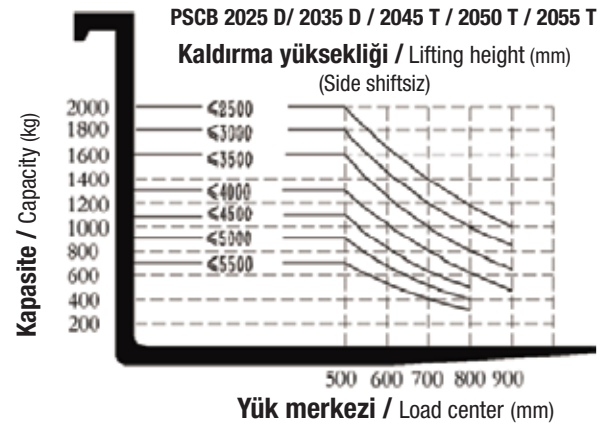
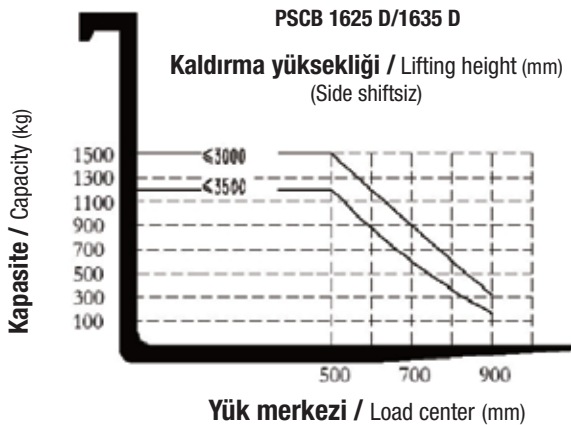

ELEKTRİKLİ ÇEKİCİLER/ ELECTRIC WALKIE TOW TRACTOR
NL-TWT 02

Yük kapasitesi / Load capacity		1000	kg
Çekme kapasitesi / Rated drawbar pull		200	N
Tekerlek mesafesi / Wheel base	(y)	325	mm
Aksa binen yük ön/arka (yükülü) / Axle loading, laden front/rear		46/16	kg
Teker türü / Wheel type (ön/arka, front/rear)		Poliüretan	
Teker ölçüsü,ön / Tire size,front		Ø 250 x 80	mm
Teker ölçüsü,arka / Tire size,rear		Ø 75 x 32	mm
Teker sayısı / Number of wheels (yön/yük, drive/load)		2 x + 2 / -	
Teker arası mesafe (ön) / Track width (front)	(b ₁₀)	185	mm
Teker arası mesafe (arka) / Track width (rear)	(b ₁₁)	380	mm
Sürüşte kontrol kolu yüksekliği / Height of tiller in drive position (min./max.)	(h _{1,d})	750/1250	mm
Makine uzunluğu / Overall length	(l ₁)	810	mm
Makine genişliği / Overall width	(b ₁)	490	mm
Gövde yerden yüksekliği / Ground clearance, centre of wheelbase	(m ₂)	38	mm
Dönme yarıçapı / Turning radius	(Wa)	475	mm
Yürüyüş hızı (yükli/yüksüz) / Traveling speed (with/without load)		4.2/4.5	km/h
Kol çekmi kuvveti (yükli/yüksüz) / Drawbar pull with/without load		200 / -	N
Max. Kol çekmi kuvveti (yükli/yüksüz) / Max. Drawbar pull (with/without load)		450 / -	N
Fren / Service brake		Elektromanyetik	
Yürüyüş motoru / Drive motor rating S2 60 min		0.3	kW
Akü / Battery voltage, nominal capacity		24/24	V/Ah
Akü ağırlık / Battery weight		16	kg
Sürüş kontrol tipi / Type of drive control		DC-Speed Control	
Gürültü seviyesi / Sound level		<62	dB (A)
Ağırlık / Weight		62	kg

İZ BIRAKMAYAN DOLGU TEKER

Kolay, güvenilir ve emniyetli akü değişimi / Easy, safe and reliable battery exchange

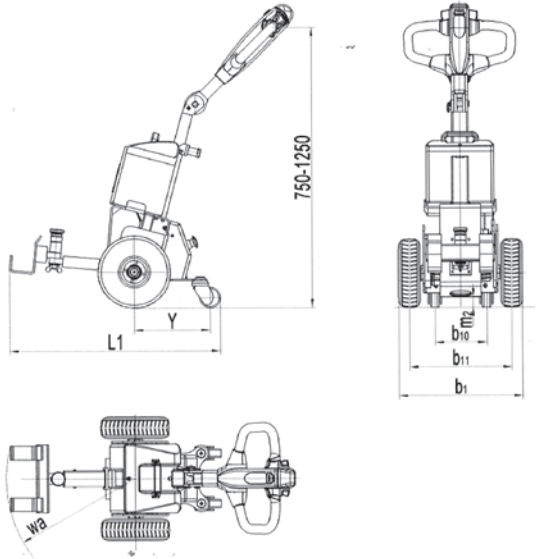
Ayarlanabilir tutma kolu / Adjustable tiller position for ergonomics

- Dar alanlarda, sık taşıma operasyonlarında ve orta mesafedeki taşımalar için kullanılır.
- Küçük depolarda veya mobilya mağazalarında taşıma araçlarının çekilmesi gibi operasyonlarda kullanılır.
- Harici şarj cihazı standarttır.
- İz bırakmayan tekerlekler standarttır.

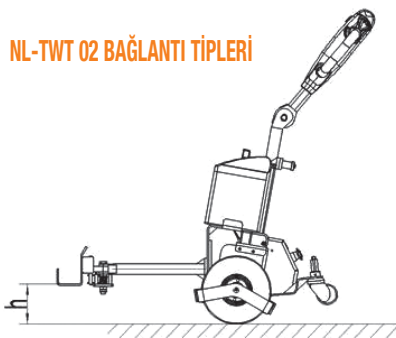
NL-TWT 02 BAĞLANTI TIPLERİ

TİP A	TİP B	TİP C	TİP D
$\phi_1 = 20 \text{ mm}, \phi_2 = 25 \text{ mm}$ $h = 148 \sim 268 \text{ mm}$ $l = 402.5 \text{ mm}$	$\phi = 20 \text{ mm},$ $h = 96 \sim 276 \text{ mm}$	$\phi = 25 \text{ mm},$ $h = 148 \sim 268 \text{ mm}$ $l = 424.5 \text{ mm}$	$w_1 = 80 \text{ mm}, w_2 = 240 \text{ mm}$ $h = 88 \sim 208 \text{ mm}$ $l = 375 \text{ mm}$

ELEKTRİKLİ ÇEKİCİLER / ELECTRIC TOWING TRACTOR/TOWING TRACTOR

NL-TWT 03

Art.No. 51000106

NL-TWT 03

Güç kaynağı / Power supply	Elektrik	
Kullanım şekli / Operating type	Oturmalı	
Teker türü / Tyres	Pnömatik lastik teker	
Teker sayısı (x=yürüyüş tekeri) yön/yük / Tyre Quantity (front / rear)	2/2x	
Maksimum çekiş gücü / Max. traction	4410 (450)	N (kgf)
Çekme kapasitesi / Traction capacity	1470 (155)	N (kgf)
Maksimum çekilen ağırlık / Traction weight	6000	kg
Sürüş hızı yüksüz/ yüklü / Driving Speed - without loaded / with loaded	17 / 7	km/h
Tırmanma kabiliyeti yüksüz/yüklü / Max. gradeability- without loaded / with loaded	30	%
Makine uzunluğu kancalı/kancasız / Overall length with hook / without hook	2000 / 1870	mm
Ön çıkıntı / Front overhang	150	mm
Arka çıkıntı / Rear overhang	370	mm
Makine genişliği / Overall width	960	mm
Toplam yükseklik / Overall height	1220	mm
Dönme yarıçapı / Turning radius	1845	mm
Kanca uzunluğu / Hook length	136	mm
Kanca yüksekliği / Hook height	290 / 340 / 390	mm
Tekerlek mesafesi / Wheelbase	1350	mm
Tekerler arası mesafe ön/arka / Tread front wheel/rear wheel	260 / 860	mm
Min. zemin yüksekliği / Ground clearance	100	mm
Platform yüksekliği / Platform height	340	mm
Toplam ağırlık akülü/aküsüz / Total weight with battery / without battery	1150 / 610	kg
Standart akü ile ağırlık dağılımı / Weight layout (with standart battery)	370 / 780	kg
Teker ölçüleri ön/arka / Tyres dimention front/rear	3,50-5-6PR / 4,00-8-6PR	mm
Akü / Battery	48 / 320	V / AH
Akü ağırlığı / Battery weight	540	kg
Yürüyüş motoru / Motor driving	AC - 4.0	kW
Sürüş kontrol tipi / Control unit type	AC - Curtis Kontrol	



- Yeni dijital AC sürüş ünitesi
New digital Ac driving unit
- Geliştirilmiş AC kontrol sistemi
Advanced AC control system
- Yenileyici fren fonksiyonu
Regenerative braking function
- Ağır hizmet süspansiyonlu koltuk
Heavy duty suspension seat

KABİN OPSİYONELDİR.

THE CABIN IS OPTIONAL

Baş üstü koruma, pencere ve silecekli

6 ton kapasiteli çekici araç

Tow Tractor 6ton with roof,
window and wiper

Üstü açık 6 ton
kapasiteli çekici araç
Tow Tractor 6ton
without roof,



ELEKTRİKLİ ÇEKİCİLER / ELECTRIC TOWING TRACTOR

NL-TWT 04

Güç kaynağı / Power supply	Elektrik / Electric	
Kullanım şekli / Operating type	Ayakta	
Teker türü / Tyres	Poliüretan	
Teker sayısı (x=yürüyüş tekeri) yön/yük / Tyre Quantity (front / rear)	1x/2/2	
Maksimum çekiş gücü / Max. traction	3000 (300)	N (kgf)
Çekme kapasitesi / Traction capacity	750 (75)	N (kgf)
Maksimum çekilen ağırlık / Traction weight	3000	kg
Sürüş hızı yüksüz/ yükülü / Driving Speed - without load / with load	7.5 / 6	km/h
Tırmanma kabiliyeti yüksüz/yükülü / Max. gradeability- without load / with load	15	%
Makine uzunluğu kancalı/kancasız / Overall length with hook / without hook	1373 / 1287	mm
Makine genişliği / Overall width	800	mm
Toplam yükseklik / Overall height	1270	mm
Dönme yarıçapı / Turning radius	1150	mm
Kanca uzunluğu / Hook length	136	mm
Kanca yüksekliği / Hook height	170/220/270/320	mm
Toplam ağırlık akülü/aküsüz / Total weight with battery / without battery	660 / 380	kg
Fren / Brake	Elektromanyetik	
Akü / Battery	24/240	V/Ah
Sürüş kontrol tipi / Control unit type	DC 1.5	kW

Art.No. 51000107

NL- TWT 04



ELEKTRİKLİ ÇEKİCİLER/ ELECTRIC WALKTQKIE TOW TRACTOR

NL-TWT 05

Sürüş tipi / Drive unit	Akülü	
Operatör tipi / Operator type	Yaya	
Kapasite / Capacity	4000	kg
Dingil mesafesi / Wheelbase	Q	1000 mm
Ağırlık (akü dahil) / Weight (with battery)	650	kg
Aksa binen yük (yük­süz) ön-arka / Axle loading (unladen) front-back	480/170	kg
Tekerlek tipi / Tyre type	Poliüretan	
Tekerlek ölçüsü (Sürüş tekeri) / Tyre size(driving wheels)	Ø 210 x 75 mm	
Tekerlek ölçüsü (Yük tekeri) / Tyre size (steering wheels)	Ø 85 x 145 mm	
Denge tekeri / Tyre size	Ø 150 x 50 mm	
Teker sayısı / Wheels number driving	1x +2/2	
Kaldırma yüksekliği / Lift height	170	mm
Toplam yükseklik / Max. Height	h15	1520 mm
Çeki oku yüksekliği / Towing coupling height	h13	205 mm
Uzunluk / Overall length	l1	1750 mm
Stand yüksekliği / Stand height	h7	150 mm
Genişlik / Overall width	b1	850 mm
Çatallar dıştan dışa mesafe / Distance between fork-arms	b5	512 mm
Yerden yükseklik / Ground clearance	m2	30 mm
Dönme yarıçapı / Turning radius	Wa	1700 mm
Sürüş hızı (yük­lü/yük­süz) / Travel speed (laden/unladen)	7/8 km	
Kaldırma hızı (yük­lü/yük­süz) / Lifting speed (laden/unladen)	0.85/0.85 m/sn	
İndirme hızı (yük­lü/yük­süz) / Lowering speed (laden/unladen)	0.30/0.30 m/sn	
Fren tipi / Brake type	Elektromanyetik	
Sürüş motoru / Drive motor	AC 1.5	kW
Kaldırma motoru / Lift motor	DC 2.0	kW
Akü / Battery	24/165	V/Ah
Akü ağırlığı / Battery weight	150	kg
Sürüş tipi / Type of drive unit	EPS	

Art.No. 51000103

NL- TWT 05

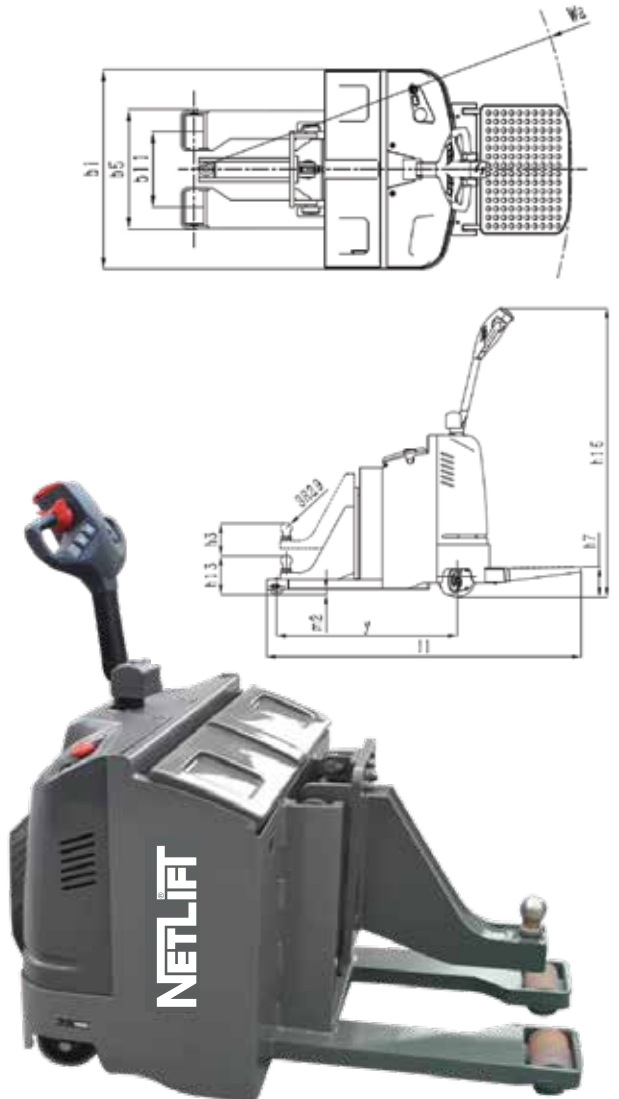



■ **Manuel Makaslı Platformlar**

Table Truck

■ **Açılı Makaslı Platformlar**

Lift and Tilt Table

■ **Elektrikli U Form Platformlar**

Electric Table Truck U Form

■ **Elektrikli Makaslı Platformlar**

Electric Table Truck

■ **Motosiklet Platformları**

Service Lifter Platforms

PLATFORMLAR
TABLE TRUCKS

PASLANMAZ ÇELİK PLATFORM / STAINLESS LIFT TABLE

	NL-STT10	NL-STT20	
Kaldırma kapasitesi / Capacity	100	200	kg
Platform ölçüsü / Platform size	700x450	830x500	mm
Platform yüksekliği / Platform height	265-755	330-910	mm
El yüksekliği / Hand height	1000	1000	mm
Tekerlek Çapı / Wheel Dia.	ø100	ø125	mm
Toplam Boyut / Overall Size	450x950	500x1010	mm
Ayak Pedalı / Foot Pedal	20	28	
Ağırlık / Net weight	40	78	kg

Art.No. 51500154

NL-STT10

Art.No. 51500155

NL-STT20

INOX



PLATFORM / TABLE TRUCK

	NL-TT 15	
Kaldırma kapasitesi / Capacity	150	kg
Min. tabla yüksekliği / Min. table height (h1)	220	mm
Max. tabla yüksekliği / Max. table height (h2)	720	mm
Tabla ölçüleri / The dimensions of table (lxbxd)	700 x 450 x 36	mm
Tekerlek ölçüsü / Caster wheel	100 x 25	mm
Maks. yükseklik için toplam pompalama / Foot pedal cycles to max. height	≈28	
Kol yüksekliği / Height of handle from the ground (h3)	950	mm
Ağırlık / Weight	46	kg

Art.No. 51500029

NL-TT 15

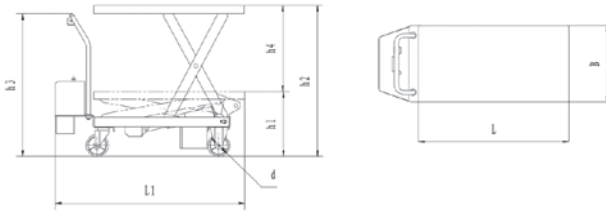

PLATFORM / TABLE TRUCK

	NL-TT 30	NL-TT 50	
Kaldırma kapasitesi / Capacity	300	500	kg
Min. tabla yüksekliği / Min. table height (h1)	285	285	mm
Max. tabla yüksekliği / Max. table height (h2)	880	880	mm
Tabla ölçüleri / The dimensions of table (lxbxd)	815 x 500 x 50	815 x 500 x 50	mm
Tekerlek ölçüsü / Caster wheel	125 x 40	125 x 40	mm
Maks. yükseklik için toplam pompalama / Foot pedal cycles to max. height	≈ 27	≈ 27	
Kol yüksekliği / Height of handle from the ground (h3)	990	990	mm
Ağırlık / Weight	77	81	kg

Art.No. 51500030

NL-TT 30

Art.No. 51500031

NL-TT 50

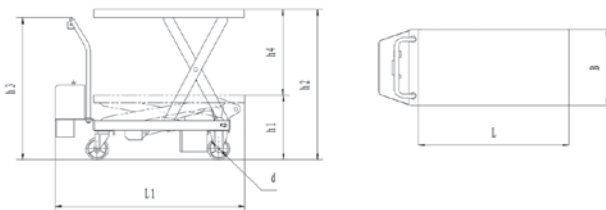

PLATFORM / TABLE TRUCK

NL-TTD 35

Art.No. 51500034

NL-TTD 35

Kaldırma kapasitesi / Capacity	350	kg
Min. tabla yüksekliği / Min. table height (h1)	355	mm
Max. tabla yüksekliği / Max. table height (h2)	1300	mm
Tabla ölçüleri / The dimensions of table (lxbxd)	910 x 500 x 53	mm
Tekerlek ölçüsü / Caster wheel	125 x 40	mm
Maks. yükseklik için toplam pompalama / Foot pedal cycles to max. height	<= 53	
Kol yüksekliği / Height of handle from the ground (h3)	975	mm
Ağırlık / Weight	105	kg

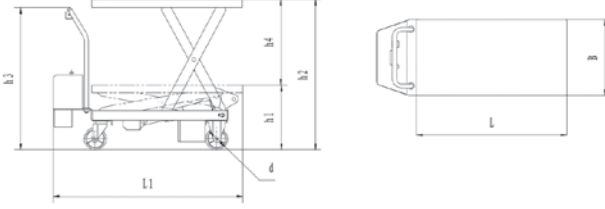

PLATFORM / TABLE TRUCK

NL-TTD 80

Art.No. 51500035

NL-TTD 80

Kaldırma kapasitesi / Capacity	800	kg
Min. tabla yüksekliği / Min. table height (h1)	445	mm
Max. tabla yüksekliği / Max. table height (h2)	1500	mm
Tabla ölçüleri / The dimensions of table (lxbxd)	1220 x 610	mm
Tekerlek ölçüsü / Caster wheel	125 x 40	mm
Maks. yükseklik için toplam pompalama / Foot pedal cycles to max. height	<= 97	
Kol yüksekliği / Height of handle from the ground (h3)	1015	mm
Ağırlık / Weight	195	kg

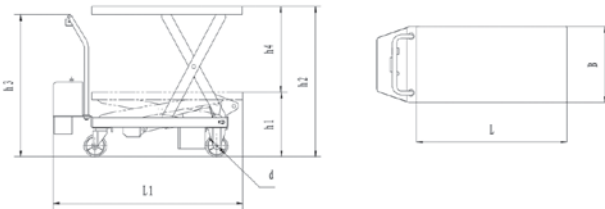

PLATFORM / TABLE TRUCK

NL-TTX 50

NL-TTX 100

Art.No. 51500036

NL-TTX 50

Art.No. 51500037

NL-TTX 100

Kaldırma kapasitesi / Capacity	500	1000	kg
Min. tabla yüksekliği / Min. table height (h1)	290	360	mm
Max. tabla yüksekliği / Max. table height (h2)	915	1360	mm
Tabla ölçüleri / The dimensions of table (lxbxd)	1600 x 810	2035 x 750	mm
Tekerlek ölçüsü / Caster wheel	125 x 40	180x50/ 80x40	mm
Maks. yükseklik için toplam pompalama / Foot pedal cycles to max. height	<= 55	<= 200	
Kol yüksekliği / Height of handle from the ground (h3)	975	1000	mm
Ağırlık / Weight	154	333	kg

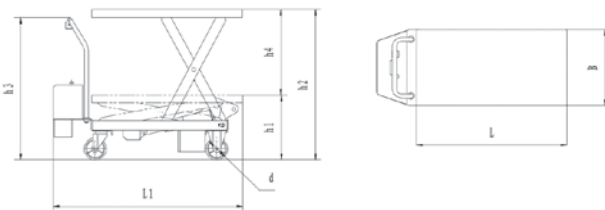

PLATFORM / TABLE TRUCK

	NL-TT 75	NL-TT 100	
Kaldırma kapasitesi / Capacity	750	1000	kg
Min. tabla yüksekliği / Min. table height	420	380	mm
Max. tabla yüksekliği / Max. table height	990	990	mm
Tabla ölçüleri / The dimensions of table	1000 x 510 x 55	1016 x 510 x 55	mm
Tekerlek ölçüsü / Caster wheel	147 x 50	125 x 50	mm
Maks. yükseklik için toplam pompalama / Foot pedal cycles to max. height	(= 45)	(= 82)	
Kol yüksekliği / Height of handle from the ground	990	980	mm
Ağırlık / Weight	125	140	kg

Art.No. 51500032

NL-TT 75

Art.No. 51500033

NL-TT 100



PLATFORM Akülü / ELECTRIC TABLE TRUCK

	NL-BTT 50	
Kaldırma kapasitesi / Capacity	500	kg
Min. tabla yüksekliği / Min. table height	440	mm
Max. tabla yüksekliği / Max. table height	1025	mm
Tabla ölçüleri / The dimensions of table	1010 x 520 x 50	mm
Tekerlek ölçüsü / Caster wheel	150 x 48	mm
Makine uzunluğu / Overall length	1305	mm
Kol yüksekliği / Height of handle from the ground	970	mm
Kaldırma hızı / Lifting speed (yükli/yüksüz, with/without load)	65/ 94	mm/s
İniş hızı / Lowering speed (yükli/yüksüz, with/without load)	98/ 74	mm/s
Dolu aküde kaldırma sayısı / Lifting cycle (ful şarj, fully charged)	100	
Akü / Battery	2 x 12/ 24	V/Ah
Dikey hareket / Vertical travel	585	mm
Kaldırma motoru / Lifting motor (DC24V)	0.8	kw
Dahili şarj cihazı / Charger (built-in)	24 V 3A	
Kaldırma hızı / Approx. lifting speed	10	s
Net ağırlık / Net weight	157	kg

Art.No. 51500038

NL-BTT 50



PLATFORM Akülü / ELECTRIC TABLE TRUCK

	NL-BTT 75	
Kaldırma kapasitesi / Capacity	750	kg
Min. tabla yüksekliği / Min. table height	420	mm
Max. tabla yüksekliği / Max. table height	970	mm
Tabla ölçüleri / The dimensions of table	1000 x 510 x 55	mm
Tekerlek ölçüsü / Caster wheel	147 x 50	mm
Makine uzunluğu / Overall length	1345	mm
Kol yüksekliği / Height of handle from the ground	935	mm
Kaldırma hızı / Lifting speed (yükli/yüksüz, with/without load)	70/ 80	mm/s
İniş hızı / Lowering speed (yükli/yüksüz, with/without load)	50/ 35	mm/s
Dolu aküde kaldırma sayısı / Lifting cycle (ful şarj, fully charged)	100	
Akü / Battery	2 x 12/ 15	V/Ah
Dikey hareket / Vertical travel	550	mm
Kaldırma motoru / Lifting motor (DC24V)	0.8	kw
Dahili şarj cihazı / Charger (built-in)	24V 3A	
Kaldırma hızı / Approx. lifting speed	12	s
Net ağırlık / Net weight	160	kg

Art.No. 51500072

NL-BTT 75



PLATFORM Akülü / ELECTRIC TABLE TRUCK

NL-BTTD 35

Art.No. 51500073

NL-BTTD 35

Kaldırma kapasitesi / Capacity	350	kg
Min. tabla yüksekliği / Min. table height	370	mm
Max. tabla yüksekliği / Max. table height	1300	mm
Tabla ölçüleri / The dimensions of table	910 x 500 x 53	mm
Tekerlek ölçüsü / Caster wheel	125 x 40	mm
Makine uzunluğu / Overall length	1210	mm
Kol yüksekliği / Height of handle from the ground	920	mm
Kaldırma hızı / Lifting speed (yükli/yüksüz, with/without load)	90/ 110	mm/s
İniş hızı / Lowering speed (yükli/yüksüz, with/without load)	100/ 90	mm/s
Dolu aküde kaldırma sayısı / Lifting cycle (ful şarj, fully charged)	100	
Akü / Battery	2 x 12 / 24	V/Ah
Dikey hareket / Vertical travel	930	mm
Kaldırma motoru / Lifting motor (DC24V)	0.8	kw
Dahili şarj cihazı / Charger (built-in)	24 V 3A	
Kaldırma hızı / Approx. lifting speed	12	s
Net ağırlık / Net weight	142	kg



AÇILI MAKASLI PLATFORM / LIFT & TILT TABLE

NL-TTA 15

NL-TTA 40

NL-TTA 80

Art.No. 51500039

NL-TTA 15

Art.No. 51500040

NL-TTA 40

Art.No. 51500041

NL-TTA 80

Kaldırma kapasitesi / Capacity	150	400	800	kg
Tabla ölçüleri UxG / Table size TxW (l x b)	830 x 500	830 x 520	830 x 520	mm
M ölçüsü / Dimensions M	830	830	930	mm
N ölçüsü / Dimensions N	748	830	830	mm
H1 Tabla yüksekliği / Table height H1 (min/max)	415/ 880	435/ 900	440/ 1000	mm
H2 Tabla yüksekliği / Table height H1 (min/max)	415/ 1400	435/ 1560	438/ 1570	mm
H3 Kol yüksekliği / Handle height H3 (min/max)	1100	1130	1130	mm
Teker çapı / Wheel diameter	125	150	150	mm
Toplam ölçüler / Overall Size	500 x 1010	520 x 1355	520 x 1355	mm
Maks. yüks. için pompalama / Foot pedal to max. height	20	55	80	
Net ağırlık / Net weight	92	123	145	kg

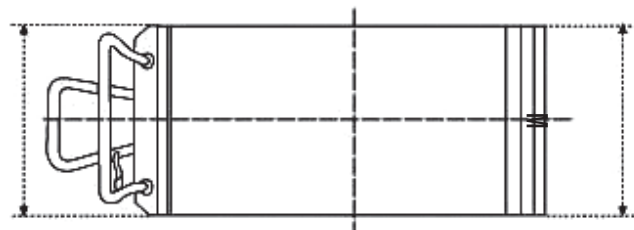
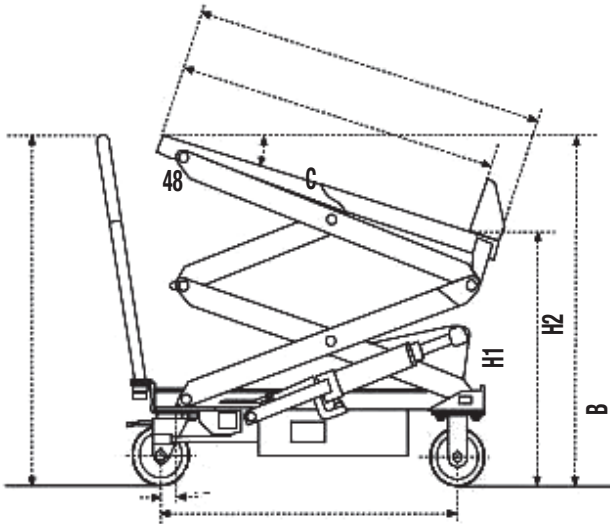

KONVEYÖR MAKASLI PLATFORM / CONVEYOR TRUCK

	NL-TTR 30	NL-TTR 50	
Kapasite / Capacity	300	500	kg
Min. yükseklik / Min. height	390	475	mm
Kaldırma yüksekliği / Lifting height	990	1000	mm
Merdane çapı / Dia. of the roller	55	55	mm
Merdane adedi / Quantity of the roller		8	adet
Merdane arası mesafe / Space between the rollers	105	105	mm
Platform ölçüsü / Platform size	840 x 510	810 x 510	mm
Ağırlık / Weight	95	150	kg

Art.No. 51500042

NL-TTR 30

Art.No. 51500043

NL-TTR 50



PLATFORM Elektrikli / ELECTRIC TABLE TRUCK

	NL-TTF 1.0	NL-TTF 2.0	NL-TTF 4.0	NL-TTF 6.0	
Kaldırma kapasitesi / Capacity	500	1000	2000	3000	kg
Min. tabla yüksekliği / Min. table height (h ₁)	190	190	190	220	mm
Max. tabla yüksekliği / Max. table height (h ₂)	1010	1010	1010	1020	mm
Platform ölçüsü / Platform size (l x b)					mm
Kaldırma süresi / Lifting time	15	25	40	26	s
Kaldırma hızı / Lifting speed (yükli, with load)	55	40	22	30	mm/s
İniş hızı / Lowering speed (yükli, with load)	40	35	33	40	mm/s
Motor / Motor	0.75	0.75	0.75	1.5	kw
Voltaj / Voltage	380	380	380	380	v
Ağırlık / Weight	160	220	280	320	kg

Art.No. 51500044

NL-TTF 1.0

Art.No. 51500045

NL-TTF 2.0

Art.No. 51500046

NL-TTF 4.0

Art.No. 51500047

NL-TTF 6.0

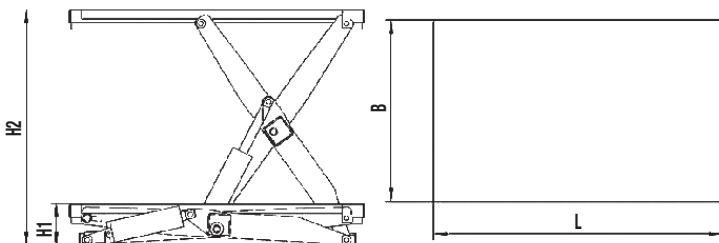

PLATFORM Elektrikli / ELECTRIC TABLE TRUCK

NL-TTG

Art.No. 51500049

NL-TTG

Kaldırma kapasitesi / Capacity	1000	kg
Min. tabla yüksekliği / Min. table height	82	mm
Max. tabla yüksekliği / Max. table height	760	mm
Platform ölçüsü / Platform size	1450 x 1140	mm
Kaldırma süresi / Lifting time	18	s
Kaldırma hızı / Lifting speed (yükü, with load)	42	mm/s
İniş hızı / Lowering speed (yükü, with load)	48	mm/s
Motor / Motor	0.75	kw
Voltaj / Voltage	380	V
Ağırlık / Net weight	250	kg



PLATFORM Elektrikli U FORM / ELECTRIC TABLE TRUCK U FORM

NL-TTU

Art.No. 51500050

NL-TTU

Kaldırma kapasitesi / Capacity	1000	kg
Min. tabla yüksekliği / Min. table height (h ₁)	80	mm
Max. tabla yüksekliği / Max. table height (h ₂)	760	mm
Platform ölçüsü / Platform size (L x B)	1450 x 1140	mm
Platform ölçüsü / Platform size (B2)	585	mm
Kaldırma süresi / Lifting time	18	s
Kaldırma hızı / Lifting speed (yükü, with load)	42	mm/s
İniş hızı / Lowering speed (yükü, with load)	48	mm/s
Motor / Motor	0.75	kw
Voltaj / Voltage	380	V
Ağırlık / Net weight	235	kg

- Uzaktan kumanda güç kontrol sistemi sayesinde kontrol ve bakım kolaylığı.
- Elektronik kontrol kutusu - acil stop butonu.
- U dizayn platform ile palet ve sandık yüklemek için ideal.
- Remote power system, easy for controlling convenient for maintenance.
- Electronic control box with up, down and emergency buttons.
- Specially designed in "u" shape for handling pallets and boxes.

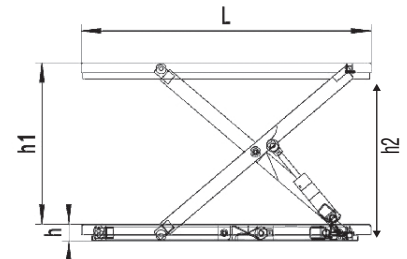
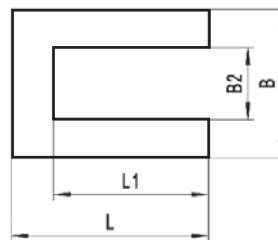

NL-TTDH Serisi



NL-TTH Serisi



NL-TTT Serisi



Art. No	Model	Kapasite / Capacity (kg)	Kapalı yükseklik / Lowered height (mm)	Açık yükseklik / Raised height (mm)	Platform ölçüsü / Platform size (mm)	Alt tabla ölçüsü / Base frame size (mm)	Kaldırma süresi / Lifting time (s)	Güç Ünitesi / Power pack	Ağırlık / Weight (kg)
51500074	NL- TTH 1001	1000	205	990	820x1300	640x1240	20~25	380V / 50HZ. AC1.1KW	160
51500075	NL- TTH 1002	1000	205	990	1000x1600	640x1240	20~25	380V / 50HZ. AC1.1KW	186
51500076	NL- TTH 1003	1000	240	1300	850x1700	640x1580	30~35	380V / 50HZ. AC1.1KW	200
51500077	NL- TTH 1004	1000	240	1300	1000x1700	640x1580	30~35	380V / 50HZ. AC1.1KW	210
51500078	NL- TTH 1005	1000	240	1300	850x2000	640x1580	30~35	380V / 50HZ. AC1.1KW	212
51500079	NL- TTH 1006	1000	240	1300	1000x2000	640x1580	30~35	380V / 50HZ. AC1.1KW	223
51500080	NL- TTH 2001	2000	230	1000	850x1300	785x1220	20~25	380V / 50HZ. AC2.2KW	235
51500081	NL- TTH 2002	2000	230	1000	1000x1600	785x1220	20~25	380V / 50HZ. AC2.2KW	268
51500082	NL- TTH 2003	2000	250	1300	850x1700	785x1600	25~35	380V / 50HZ. AC2.2KW	289
51500083	NL- TTH 2004	2000	250	1300	1000x1700	785x1600	25~35	380V / 50HZ. AC2.2KW	300
51500084	NL- TTH 2005	2000	250	1300	850x2000	785x1600	25~35	380V / 50HZ. AC2.2KW	300
51500085	NL- TTH 2006	2000	250	1300	1000x2000	785x1600	25~35	380V / 50HZ. AC2.2KW	315
51500086	NL- TTH 4001	4000	240	1050	1200x1700	900x1600	30~40	380V / 50HZ. AC2.2KW	375
51500087	NL- TTH 4002	4000	240	1050	1200x2000	900x1600	30~40	380V / 50HZ. AC2.2KW	405
51500088	NL- TTH 4003	4000	300	1400	1000x2000	900x2000	45~50	380V / 50HZ. AC2.2KW	470
51500089	NL- TTH 4004	4000	300	1400	1200x2000	900x2000	45~50	380V / 50HZ. AC2.2KW	490
51500090	NL- TTH 4005	4000	300	1400	1000x2200	900x2000	45~50	380V / 50HZ. AC2.2KW	480
51500091	NL- TTH 4006	4000	300	1400	1200x2200	900x2000	45~50	380V / 50HZ. AC2.2KW	505
51500125	NL- TTH 4007	4000	350	1780	1700x1500	640x1240	35~45	380V / 50HZ. AC2.2KW	510
51500126	NL- TTH 4008	4000	350	1300	1700x1500	1620x1400	35~45	380V / 50HZ. AC2.2KW	570
51500092-1	NL- TTDH 1000	1000	305	1785	820x1300	735x1240	35~45	380V / 50HZ. AC2.2KW	655
51500093	NL- TTDH 2000	2000	360	1780	850x1300	785x1220	35~45	380V / 50HZ. AC2.2KW	595
51500127	NL- TTDH 4000	4000	400	2050	1700x1200	1600x900	55~65	380V / 50HZ. AC2.2KW	520
51500048	NL- TTT 1.0	1000	470	3000	1700x1000	1600x1000	35~45	380V / 50HZ. AC2.2KW	450
51500053	NL- TTT 2.0	2000	560	3000	1700x1000	1606x1010	50~60	380V / 50HZ. AC2.2KW	750

Ağır Hizmet Tasarımı

TTH serisi Çalışma Platformu AB normlarını ve ANSI/ASME emniyet standartlarını karşılamaktadır. Bu modeller zemin altı ve zemin üstü kanal uygulamalarında kullanılabilir.

Standart Emniyet Özellikleri

Üst platform, kaldırma esnasında bir engelle temas ettiğinde düşmesini önlemek amacıyla, alüminyum emniyet barı ile birlikte kaldırılır. Düşük voltaj (24 V) kumanda kutusu, aşağı-yukarı butonu ile. Aşırı yüklenmelere karşı emniyet vanası ve kontrollü indirme hız ayarı için kompanse akış vanalı dahili güç paketi. Drenaj sistemli ve hortum patlaması durumunda tablanın düşüşünü engelleyen kontrol vanalı ağır hizmet silindirleri. Çalışma esnasında sıkışmaya engel olacak şekilde makaslar arasında emniyet mesafesi.

Diğer Standart Özellikler

Pimli bağlantılarda kendinden yağlama yatakları.
Taşmayı ve tabla montajını kolaylaştıran çıkarılabilir kaldırma gözü.
Yüksek kaliteli AC güç paketleri Avrupa'da yapılmaktadır.

Heavy Duty Design

TTH series lift tables meet EN norm and ANSI/ASME safety standards. These models can be used for above-floor or in-floor pit applications.

Standart of Safety Features

Upper platform lifted with aluminum safety bar preventing descent on contact with obstructions. Low-Tension (24V) control box with up-down buttons. Internal power pack equipped with relief valve against overloading and compensated flow valve for controlled lowering speed. Heavy duty cylinders with drainage system and check valve to stop the lift table lowering in case of hose burst. Safety clearance between scissors to prevent trapping during operation.

Other Standard Features

Self lubricating bushings on pivot points.
Removable lifting eye to facilitate handling and lift table installation.
High quality AC power packs are made in Europe.

HİDROLİK MOTOSİKLET SERVİS LİFTİ / HYDRAULIC MOTORCYCLE SERVICE LIFTER

NL-TC 150

Art.No. 51500051

NL-TC 150

Kaldırma kapasitesi / Capacity	150 kg
Max. platform yüksekliği / Max. platform height	1070 mm
Min. platform yüksekliği / Min. platform height	145 mm
Platform ölçüleri / Platform size	1400 x 470 mm
Maks.yükseklik için pompa sayısı / Foot pedal to max. height	40
Net ağırlık / Net weight	100 kg

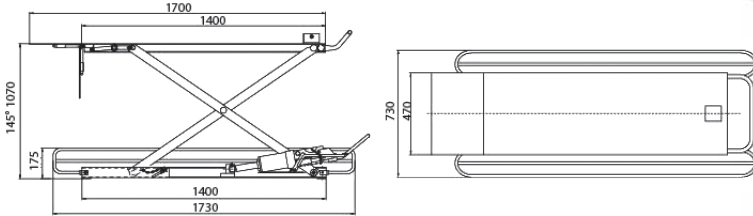

HİDROLİK MOTOSİKLET SERVİS LİFTİ / HYDRAULIC MOTORCYCLE SERVICE LIFTER

NL-TC 500

Art.No. 51500052

NL-TC 500

Kaldırma kapasitesi / Capacity	500 kg
Max. platform yüksekliği / Max. platform height	800 mm
Min. platform yüksekliği / Min. platform height	170 mm
Platform ölçüleri / Platform size	2200 x 700 mm
Net ağırlık / Net weight	235 kg

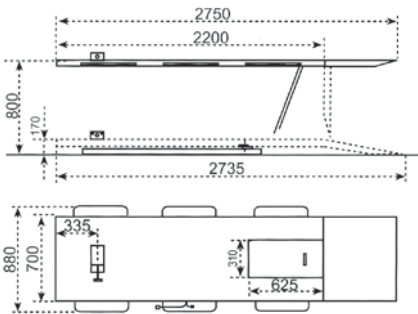

HİDROLİK MOTOSİKLET SERVİS LİFTİ / HYDRAULIC MOTORCYCLE SERVICE LIFTER

NL-TE 500

Art.No. 51500054

NL-TE 500

Kaldırma kapasitesi / Capacity	500 kg
Max. platform yüksekliği / Max. platform height	800 mm
Min. platform yüksekliği / Min. platform height	170 mm
Platform ölçüleri / Platform size	2200 x 700 mm
Kaldırma süresi / Lifting time	8/ 15 s
Güç ünitesi / Power pack	380V/ 50Hz, AC 1.1 kw
Net ağırlık / Net weight	240 kg

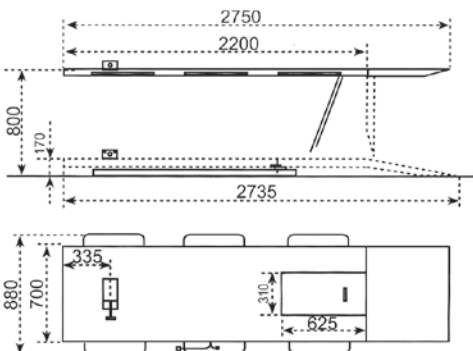



100 TON'A KADAR MALZEMELERİ İTMEK - ÇEKMEK - YÖNLENDİRMEK ARTIK ÇOK KOLAY



Elektrik veya hava tahrikli bu minik araç; uçak, helikopter gibi hava araçlarını park sahalarına yerleştirmek, çelik, kağıt, kablo, halat rulolarını itmek, otomotiv sanayiinde imalat veya bakım sürecindeki kamyon, otobüs ve iş makinalarını itmek için ideal bir üründür.



C1500A



CF1500A



V1250B



NET MAK®
METAL MAKİNA SANAYİ VE TİCARET LTD. ŞTİ.



- **Alüminyum Tek Direk Çalışma Platformları**
Single Mast Mobile Aluminum Work Platform
- **Alüminyum Çift Direk Çalışma Platformları**
Double Mast Mobile Aluminum Work Platform
- **Raf Yerleştirme / Sipariş Toplama Aracı**
Order Pickers
- **Akülü Makaslı Platformlar**
Powered Scissor Aerial Work Platform

PERSONEL YÜKSELTİCİLER
AERIAL WORK PLATFORM

ALÜMİNYUM TEK DİREK ÇALIŞMA PLATFORMU / SINGLE MAST MOBILE ALUMINUM WORK PLATFORM

	NL-SMAP 6.0	NL-SMAP 8.0	NL-SMAP 10.0		
Platform kapasitesi / Access platform capacity	150	125	125	kg	
Maksimum personel sayısı / Max. occupants	1	1	1		
Çalışma yüksekliği / Working height	8	10	12	m	
Platform yüksekliği / Platform floor height	6	8	10	m	
Makine boyu / Overall length	1.42	1.42	1.42	m	
Makine genişliği / Overall width	0.78	0.78	0.78	m	
Makine yüksekliği / Overall height	1.92	1.93	1.93	m	
Platform ölçüsü / Platform size	0.66 x 0.69			m	
Zemin açıklığı / Ground clearance	0.05			m	
Teker arası mesafesi / Wheelbase	1.12			m	
Kaldırma motoru / Lifting motor	AC	110 - 230 / 1.5		VAC/kW	
	DC	12 / 1.5		VDC/kW	
Kaldırma-indirme hızı / Up-down speed	36 / 33	40 / 36	45 / 36	s	
Arka tekerlekler / Back wheels	Ø 180x50	Ø 180x50	Ø 180x50	mm	
Ön tekerlekler / Front wheels	Ø 150x50	Ø 150x50	Ø 150x50	mm	
Akü / Battery					
Ağırlık / Weight	AC - DC	380 - 401	404 - 430	445 - 471	kg

(Opsiyonel) akülü modeller için müşteri temsilcileri ile irtibata geçiniz.
Please contact customer representative for (optional) battery powered models.

ELEKTRİKLİ ELECTRIC	Art.No. 51500130	NL-SMAP 6.0
	Art.No. 51500006	NL-SMAP 8.0
	Art.No. 51500007	NL-SMAP 10.0
AKÜLÜ BATTERY	Art.No. 51500059	NL-SMAP 6.0-1
	Art.No. 51500060	NL-SMAP 8.0-1
	Art.No. 51500061	NL-SMAP 10.0-1

Standard ekipmanlar

- Ayarlanabilir denge ayakları
- Acil durum durdurma butonu
- Akü şarj göstergesi (Akülü modelde)
- Elektrik limit anahtarı
- Zeminden ve platformdan kontrol imkanı
- Acil durum indirme valfi
- Seviye göstergesi (su terazisi)
- Aşırı yük koruma
- Forklift cepleri
- Nakliye bağlama noktası

Opsiyonel seçenekler

- Aşırı yük sensörü
- Platformda elektrik prizi
- Tüm hareketlerde sesli uyarı
- Uyarı lambası
- Entegre şarj cihazı

Standard equipment

- Swing out outriggers with interlock
- Emergency stop button
- Battery charge indicator
- Electric limit switch
- Grand & Platform (For battery powered)
- Emergency lowering system
- Leveling indicator
- Forklift pockets
- Transport tie hole

Optional equipments

- Overload sensor with buzzer
- AC power to platform
- All motion alarm
- Beacon
- DC power with charger

Elektrikli



Akülü

Entegre şarj cihazı

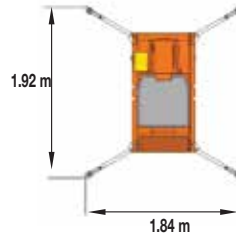

NL-SMAP : 1.92 m
NL-SMAP 8.0 : 1.93 m
NL-SMAP 10.0 : 1.93 m

NL-SMAP 6.0 : 8 m
NL-SMAP 8.0 : 10 m
NL-SMAP 10.0 : 12 m

NL-SMAP : 6 m
NL-SMAP 8.0 : 8 m
NL-SMAP 10.0 : 10 m



ALÜMİNYUM ÇİFT DİREK ÇALIŞMA PLATFORMU / DUAL MAST MOBILE ALUMINUM WORK PLATFORM

	NL-DMAP 6.0	NL-DMAP 8.0	NL-DMAP 10.0	NL-DMAP 12.0	NL-DMAP 14.0	
Platform kapasitesi / Access platform capacity	300	300	250	200	200	kg
Maksimum personel sayısı / Max. occupants	2	2	2	2	2	
Çalışma yüksekliği / Working height	8	10	12	14	16	m
Platform yüksekliği / Platform floor height	6	8	10	12	14	m
Makine boyu / Overall length	1.53	1.53	1.79	1.79	1.86	m
Makine genişliği / Overall width	0.82	0.82	0.82	0.87	0.95	m
Makine yüksekliği / Overall height	1.81	1.81	1.86	2.03	2.3	m
Platform ölçüsü / Platform size	1.28x0.66	1.28x0.66	1.54x0.66	1.54x0.66	1.48x0.62	m
Zemin açıklığı / Ground clearance	0.08	0.08	0.08	0.08	0.06	m
Teker mesafesi / Wheelbase	1.18	1.18	1.44	1.44	1.44	m
Kaldırma motoru / Lifting motor	AC	110 - 230 / 1.5	110 - 230 / 1.5	110 - 230 / 1.5	110 - 230 / 1.5	VAC/kW
	DC	12 / 1.5	12 / 1.5	12 / 1.5	12 / 1.5	24 / 1.5 VDC/kW
Kaldırma-indirme hızı / Up-down speed	0.062 / 0.043	0.062 / 0.043	0.070 / 0.046	0.075 / 0.054	0.073 / 0.058	m/sn
Arka tekerlekler / Back wheels	Ø 200x50	Ø 200x50	Ø 200x50	Ø 200x50	Ø 150x50	mm
Ön tekerlekler / Front wheels	Ø 200x50	Ø 200x50	Ø 200x50	Ø 200x50	Ø 150x50	mm
Ağırlık / Weight	AC - DC	600 - 640	630 - 670	730 - 770	825 - 865	750 - 815 kg

ELEKTRİKLİ ELECTRIC	Art.No. 51500131	NL-DMAP 6.0
	Art.No. 51500008	NL-DMAP 8.0
	Art.No. 51500009	NL-DMAP 10.0
	Art.No. 51500010	NL-DMAP 12.0
	Art.No. 51500147	NL-DMAP 14.0
AKÜLÜ BATTERY	Art.No. 51500002	NL-DMAP 6.0-1
	Art.No. 51500005	NL-DMAP 8.0-1
	Art.No. 51500014	NL-DMAP 10.0-1
	Art.No. 51500021	NL-DMAP 12.0-1
	Art.No. 51500022	NL-DMAP 14.0-1

Standard ekipmanlar

- Ayarlanabilir denge ayakları
- Acil durum durdurma butonu
- Akü şarj göstergesi
- Elektrik limit anahtarı
- Zeminden ve platformdan kontrol imkanı
- Acil durum indirme valfi
- Seviye göstergesi (su terazisi)

Standard equipment

- Swing out outriggers with interlock
- Emergency stop button
- Battery charge indicator
- Electric limit switch
- Grand & Platform (For battery powered)
- Emergency lowering system
- Leveling indicator

Seçenekler

- Aşırı yük sensörü
- Platformda elektrik prizi
- Tüm hareketlerde sesli uyarı
- Uyarı lambası
- Entegre şarj cihazı

Options

- Overload sensor with buzzer
- AC power to platform
- All motion alarm
- Beacon
- DC power with charger

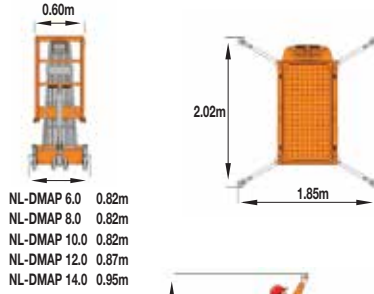
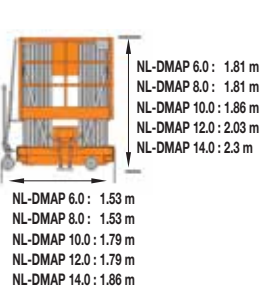

NL-DMAP 6.0 : 8 m
 NL-DMAP 8.0 : 10 m
 NL-DMAP 10.0 : 12 m
 NL-DMAP 12.0 : 14 m
 NL-DMAP 14.0 : 16 m

NL-DMAP 6.0 6m
 NL-DMAP 8.0 8m
 NL-DMAP 10.0 10m
 NL-DMAP 12.0 12m
 NL-DMAP 14.0 14m



AKÜLÜ YÜRÜTMELİ TEK - ÇİFT DİREK ÇALIŞMA PLATFORMU / SINGLE-DOUBLE MAST ALUMINIUM WORK PLATFORM

Art.No. 51500025	NL-FEAP / S 6.0
Art.No. 51500026	NL-FEAP / S 7.5
Art.No. 51500027	NL-FEAP/D 7.5
Art.No. 51500028	NL-FEAP/D 9.0

	NL-FEAP/S 6.0	NL-FEAP/S 7.5	NL-FEAP/D 7.5	NL-FEAP/D 9.0	
Kaldırma kapasitesi / Capacity	150	125	200	150	kg
Maksimum personel sayısı / Max. occupants	1	1	1	1	
Çalışma yüksekliği / Working height	8.00	9.50	9.50	11	m
Platform yüksekliği / Platform height	6.00	7.50	7.50	9	m
Makine boyu / Overall length	1.40	1.40	1.55	1.55	m
Makine genişliği / Overall width	0.82	0.82	1.01	1.01	m
Makine yüksekliği / Overall height	1.98	1.98	2.00	2.00	m
Platform ölçüsü / Platform size	0.78 x 0.70	0.78 x 0.70	1.00 x 0.70	1.00 x 0.70	m
Platform genişletme ölçüsü / Platform extension size	0.55	0.55			m
Zemin açıklığı / Ground clearance	0.05	0.05	0.08	0.08	m
Teker mesafesi / Wheelbase	1.14	1.14	1.23	1.23	m
Dönme çapı / Turning radius (iç/dış, inside/outside)	0	0	0 / 1.9	0 / 1.9	m
Yürüyüş motoru / Driving motor	2 x 24/ 0.4	2 x 24/ 0.4	2 x 24/ 0.5	2 x 24/ 0.5	VDC/KW
Kaldırma motoru / Lifting motor	24/ 2	24/ 2	24/ 2	24/ 2	VDC/KW
Kapalı hız / Travel speed (stowed)	4	4	4	4	km/h
Açık hız / Travel speed (raised)	1.1	1.1	1.1	1.1	km/h
Kaldırma-indirme hızı / Up-down speed	43/ 35	48/ 40	42/ 31	45/ 34	s
Akü / Battery	2 x 12/ 120	2 x 12/ 120	2 x 12/ 120	2 x 12/ 120	V/Ah
Şarj cihazı / Integretad charger	24/ 10A	24/ 12	24/ 10	24/ 10	V/A
Eğim / Gradeability	25	25	25	25	%
Maksimum eğim / Maximum slope	1.5	1.5	2	2	°
Sürüş tekerleği / Drive wheels	230 x 80	230 x 80	305 x 100	305 x 100	mm
Ön tekerlekler / Front wheels	8	8			in
Ağırlık / Weight	914	940	1270	1345	kg

Standard ekipmanlar

- Hassas kontroller
- Otomatik engel koruması
- Platformda kendinden kapanır kapı
- Maks. yükseklikte hareket imkanı
- İz bırakmayan tekerlek
- 2WD
- Otomatik fren sistemi
- Acil durum indirme valfi
- Akü şarj göstergesi
- Acil durdurma butonu
- Hidrolik emniyet valfi
- Platformda hata göstergesi
- Eğim alarmı
- Tüm hareketlerde sesli uyarı
- Korna
- Saat sayacı
- Forklift çepçeri
- Şarj koruması
- Flaşlı uyarı lambası
- Şaşıden ve platformdan kumanda

Standard equipment

- Proportional controls
- Automatic pothole protection
- Self-closing gate on platform
- Drivable at full height
- Non-marking tyre
- 2WD
- Automatic brake system
- Emergency lowering system
- Emergency stop button
- Cylinder holding valve
- Onboard diagnostic system
- Tilt sensor with alarm
- All motion alarm
- Horn
- Hour meter
- Forklift pockets
- Charger protection
- Flashing beacon
- Operation at chassis and platform

Seçenekler

- Aşırı yük uyarısı
- Platformda elektrik prizi
- Platform çalışma ışığı
- Platformda hava hattı

Options

- Overload sensor with buzzer
- AC power to platform
- Platform work lights
- Airline to platform



Opsiyonel / Optional:
Genişletilmiş platform / Extended platform



NL-FEAP/D 1.01 m
NL-FEAP/S 0.82 m

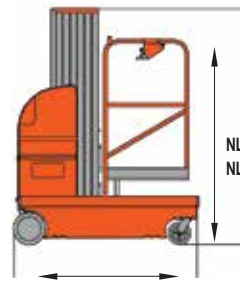

NL-FEAP/D 1.55 m
NL-FEAP/S 1.40 m

NL-FEAP/D 2.0 m
NL-FEAP/S 1.98 m



NL-FEAP / S



NL-FEAP / D

NL-FEAP/D 7.5 : 9.5 m
NL-FEAP/D 9.0 : 11 m
NL-FEAP/S 6.0 : 8 m
NL-FEAP/S 7.5 : 9.5 m

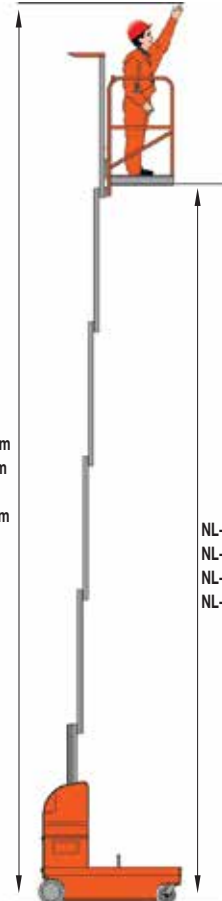

NL-FEAP/D 7.5 : 7.5 m
NL-FEAP/D 9.0 : 9 m
NL-FEAP/S 6.0 : 6 m
NL-FEAP/S 7.5 : 7.5 m



Acil Durum İndirme Sistemi



Forklift Çepleri



Eğim



Dar Alanlarda Manevra
Kabiliyeti



Uyarı
Lambası



Acil Durum İndirme
Sistemi

AKÜLÜ YÜRÜTMELİ RAF YERLEŞTİRME MAKİNESİ (3 mastlı) / ELECTRIC AERIAL ORDER PICKER (3 masts)

	NL-OPP 3.5/3 FE	NL-OPP 4.0/3 FE	NL-OPP 4.5/3 FE	
Kaldırma kapasitesi / Capacity	300	300	300	kg
Maksimum personel sayısı / Max. occupants	1	1	1	
Çalışma yüksekliği / Working height	5.50	6.00	6.50	m
Platform yüksekliği / Platform Floor height	3.50	4.00	4.50	m
Makine boyu / Overall length	1.56	1.56	1.56	m
Makine genişliği / Overall width	0.76	0.76	0.76	m
Makine yüksekliği / Overall height	1.64	1.81	1.99	m
Platform ölçüsü / Platform size	0.93 x 0.70	0.93 x 0.70	0.93 x 0.70	m
Zemin açıklığı / Ground clearance	0.04	0.04	0.04	m
Teker mesafesi / Wheelbase	1.23	1.23	1.23	m
Dönme yarıçapı / Turning radius	1.72	1.72	1.72	m
Sürüş motoru / Drive motors	2 x 24/ 0.4	2 x 24/ 0.4	2 x 24/ 0.4	VDC/kW
Kaldırma Motoru / Lifting motor	24/ 2	24/ 2	24/ 2	VDC/kW
Kapalı hız / Travel speed (stowed)	4	4	4	km/h
Açık hız / Travel speed (raised)	1.1	1.1	1.1	km/h
Kaldırma-indirme hızı / Up-down speed	20 / 18	22 / 19	24 / 21	m/sn
Akü / Battery	2 x 12/ 120	2 x 12/ 120	2 x 12/ 120	V/Ah
Şarj cihazı / Integretad charger	24/ 10	24/ 10	24/ 10	V/A
Eğim / Gradeability	25	25	25	%
Sürüş tekerleği / Drive wheels	Ø 230 x 80	Ø 230 x 80	Ø 230 x 80	mm
Ön tekerlekler / Front wheels	6	6	6	in
Ağırlık / Weight	642	662	682	kg

Art.No. 51500098	NL-OPP 3.5/3 FE
Art.No. 51500099	NL-OPP 4.0/3 FE
Art.No. 51500100	NL-OPP 4.5/3 FE

Standard ekipmanlar

- Hassas kontroller
- Platformda kendinden kapanır kapı
- Maks. yükseklikte hareket imkanı
- İz bırakmayan tekerlek
- 2WD
- Otomatik fren sistemi
- Acil durum indirme valfi
- Acil durdurma butonu
- Hidrolik emniyet valfi
- Platformda hata göstergesi
- Forklift cepleri
- Şarj koruması

Seçenekler

- Aşırı yük uyarısı
- Platform çalışma ışığı
- Tüm hareketlerde sesli uyarı
- Çalışma saati
- İkaz lambası
- Akü şarj göstergesi

Standard equipment

- Proportional controls
- Self-closing gate on platform
- Drivable at full height
- Non-marking tyre
- 2WD
- Automatic brake system
- Emergency lowering system
- Emergency stop button
- Cylinder holding valve
- Onboard diagnostic system
- Forklift pockets
- Charger protection

Options

- Overload sensor with alarm
- Platform work lights
- All motion buzzer
- Hour meter
- Flashing beacon
- Charge indicator



NL-OPP 3.5/3 FE : 1.64 m
NL-OPP 4.0/3 FE : 1.81 m
NL-OPP 4.5/3 FE : 1.99 m

NL-OPP 3.5/3 FE : 5.50 m
NL-OPP 4.0/3 FE : 6.00 m
NL-OPP 4.5/3 FE : 6.50 m

NL-OPP 3.5/3 FE : 3.50 m
NL-OPP 4.0/3 FE : 4.00 m
NL-OPP 4.5/3 FE : 4.50 m

Akülü kaldırma / Akülü yürütme

PERSONEL YÜKSELTİCİLER
Aerial Work Platforms



Forklift Çepleri



Platformda Kendinden Kapanır Kapı



Acil Durum İndirme Sistemi



Mekanik Durdurucu

SİPARİŞ TOPLAMA ARACI / ORDER PICKER

NL-OPP 3 PRO

NL-OPP 4 PRO

NL-OPP 4.8 PRO

Güç / Power		Elektrikli	Elektrikli	Elektrikli	
Operatör tipi / Operator type		Ayakta	Ayakta	Ayakta	
Ön platformda nominal kapasite / Rated capacity on front platform	Q1	227	227	227	kg
Platformun arkasındaki nominal kapasite / Rated capacity on behind platform	Q2	137	137	137	kg
Ayakta duran platformda nominal kapasite / Rated capacity on standing platform	Q3	136	136	136	kg
Tekerlek mesafesi / Wheelbase	y	1150	1150	1150	mm
Ağırılık (akü dahil) / Service weight (include battery)		1160	1160	1160	kg
Aksa binen yük (yükli sürüş tarafı / yüklemeye tarafı) / Axle loading (laden driving side/loading side)		680/980	680/980	680/980	kg
Aksa binen yük (yüksüz sürüş tarafı / yüklemeye tarafı) / Axle loading (unladen driving side/loading side)		490/670	490/670	490/670	kg
Teker türü (yürüyüş / yük) / Tyre type (driving/loading)		Poliüretan	Poliüretan	Poliüretan	
Yön teker ölçüsü (çap x genişlik) / Tyre type, driving wheels (dia. x width)		Ø 230x75	Ø 230x75	Ø 230x75	mm
Yük teker ölçüsü (çap x genişlik) / Tyre type, loading wheels (dia. x width)		Ø 204x75	Ø 204x75	Ø 204x75	mm
Denge teker ölçüsü (çap x genişlik) / Tyre type, caster wheels(dia. x width)		Ø 74x48	Ø 74x48	Ø 74x48	mm
Teker sayısı (yön/yük) / Wheels, number driving, caster/loading (x=drive wheels)		1x 2/2	1x 2/2	1x 2/2	
Ön yük platformu / Tread, front	b10	566	566	566	mm
Arka yük platformu / Tread, rear	b11	724	724	724	mm
Mast kapalı yükseklik / Height, mast lowered	h1	1510	1510	1510	mm
Kaldırma yüksekliği / Lift height	h3	2950	2950	2950	mm
Mast açık yükseklik / Height, mast extended	h4	4540	4540	4540	mm
Kabin koruma yüksekliği (kabin) / Height of overhead guard (cabin)	h6	1590	1590	1590	mm
Koltuk yüksekliği / ayakta yükseklik / Seat height / standing height	h7	250	250	250	mm
Stand yüksekliği, yükseltilmiş / Stand height, elevated	h12	3200	3200	3200	mm
Makine uzunluğu / Overall length	l1	1500	1500	1500	mm
Makine genişliği / Overall width	b1/b2	800	800	800	mm
Zemin açıklığı / Ground clearance, center of wheel base	m2	50	50	50	mm
Ön yük platformu genişliği / Front cargo platform width		800x520	800x520	800x520	mm
Ön yük platformunun ilk yüksekliği / Initial height of front cargo platform		1082	1082	1082	mm
Kontrol kolu yüksekliği / Control handle height		1010	1010	1010	mm
Arka platform genişliği / Behind platform width		346x660	346x660	346x660	mm
Platform dahil uzunluk / Overall length platform launch	l3	1795	1795	1795	mm
Koridor genişliği / The channel width	Ast	2005	2005	2005	mm
Dönme yarıçapı / Turning radius	Wa	1385	1385	1385	km/h
Yürüyüş hızı (yükli / yüksüz) / Travel speed (laden/unladen) h12: 0-520mm		5.5	5.5	5.5	km/h
Yürüyüş hızı (yükli / yüksüz) / Travel speed (laden/unladen) h12: 520-1940mm		3.7	3.7	3.7	km/h
Yürüyüş hızı (yükli / yüksüz) / Travel speed (laden/unladen) h12: 1940-2600mm		2.5	2.5	2.5	km/h
Yürüyüş hızı (yükli / yüksüz) / Travel speed (laden/unladen) h12: 2600mm maks.		1	1	1	km/h
Geri yürüyüş hızı (yükli / yüksüz) / Travel speed (laden/unladen) backWards h12: 0-520mm		5.5	5.5	5.5	km/h
Geri yürüyüş hızı (yükli / yüksüz) / Travel speed (laden/unladen) backWards h12: 520-1940mm		3.7	3.7	3.7	km/h
Geri yürüyüş hızı (yükli / yüksüz) / Travel speed (laden/unladen) backWards h12: 1940-2600mm		2.5	2.5	2.5	km/h
Geri yürüyüş hızı (yükli / yüksüz) / Travel speed (laden/unladen) backWards h12: 2600mm maks.		1	1	1	km/h
Kaldırma hızı (yükli / yüksüz) / Lifting speed (laden/unladen)		0.17 / 0.21	0.17 / 0.21	0.17 / 0.21	m/sn
İndirme hızı (yükli / yüksüz) / Lowering speed (laden/unladen)		0.35 / 0.26	0.35 / 0.26	0.35 / 0.26	m/sn
Tırmanma kabiliyeti (yükli / yüksüz) / Max. gradeability (laden/unladen)		0	0	0	%
Fren tipi / Service brake		ElkroManyetik	ElkroManyeti	ElkroManyeti	
Yürüyüş motoru / Drive motor rating S2 60 min.		1.7	1.7	1.7	kW
Kaldırma motoru / Lift motor rating at S3 15%		2.2	2.2	2.2	kW
Akü / Battery voltage/nominal capacity K20		24V / 224	24V / 224	24V / 224	V/Ah
Akü ağırlığı / Battery weight		163	163	163	kg
Sürüş kontrol tipi / Type of drive control		AC	AC	AC	
Direksiyon tasarımı / Steering design		Elektronik	Elektronik	Elektronik	
Gürültü seviyesi / Sound pressure level at the driver's ear		74	74	74	dB (A)

PROFESYONEL SERİ

SİPARİŞ TOPLAMA ARACI / ORDER PICKER PLATFORM

Art.No. 51500182

NL-OPP 3 PRO

Art.No. 51500183

NL-OPP 4 PRO

Art.No. 51500184

NL-OPP 4.8 PRO

• Tek parça kapak bakım amacıyla güç aktarım elemanlarına ulaşılabilmesi açısından büyük kolaylık sağlar.

Single piece cover provides great convenience in terms of reaching power transmission elements for maintenance.

• Ekstra büyük 225 kg kapasiteli ön yük platformu.

Extra large front platform with 225 kg capacity.

• AC tahrikli elektronik direksiyon sezgisel ve hassas bir manevra kabiliyeti sağlar.

AC driven electronic steering provides intuitive and precise maneuverability.

• Dayanıklı çelik gövde arka saklar tepsisini muhafaza etmekle beraber yükselmiş haldeyken üstün bir denge sağlanabilmesi için i-profil kanal direğini destekler.

Durable steel body retains the rear storage tray. It also supports i-profile channel post for superior stability when it's raised.

LCD ÖN PANEL EKRANI
(4 FARKLI HIZ SEÇİMİ)

ERGONOMİK BUTONLAR
KUMANDA

YÜKSEK GÖRÜNÜRLÜĞE SAHİP
OPERATÖR BÖLMESİ



Yandan raylı sistem ile kolay çıkabilen akü
Easy removable battery with side rail system.

• Özel 224 AH AGM akü grubu 220 V şarj cihazı ile birlikte şarj edilebilmeyi desteklemekte ve 4 saate kadar kesintisiz çalışma süresi sunmaktadır.

Special 224 AH AGM battery pack supports charging with a 200 V charger. It also provides up to 4 hours of continuous working.

• 240 mm lik alçak basamak yüksekliği araca binerken ve araçtan inerken kolaylık sağlar.

The low step height of 240 mm provides comfort when getting in and out of the vehicle.

HARİCİ ŞARJ CİHAZI EXTERNAL CHARGER

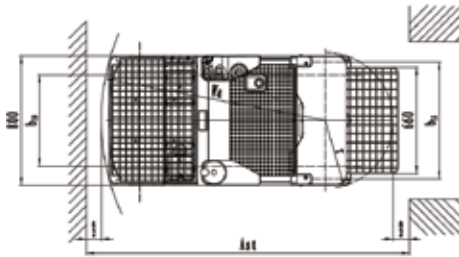

Art.No. 51500185
a=200



**Yük arabası standart olmayıp opsiyonel aksesuardır.
Çekilecek malzemeye göre özel olarak tasarlanabilir.**

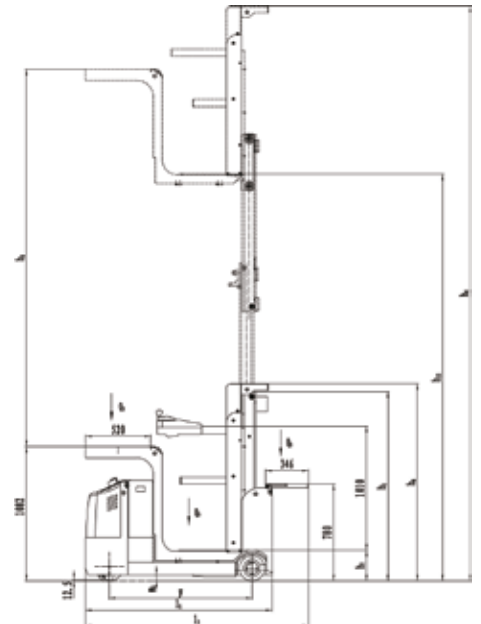

Art.No. 51500011	NL-MP 3060
Art.No. 51500012	NL-MP 3090
Art.No. 51500013	NL-MP 3011

MAKASLI PLATFORM (Manuel yürütme) / SCISSOR LIFT PLATFORM

	NL-MP 3060	NL-MP 3090	NL-MP 3011
Platform kapasitesi / Access platform capacity	300	300	300
Çalışma yüksekliği / Working height	8	11	13
Platform yüksekliği / Platform floor height	6	9	11
Makine boyu / Overall length	1900	2250	2250
Makine genişliği / Overall width	1070	1070	1420
Makine yüksekliği / Overall height	0.95	1.5	1.6
Platform ölçüsü / Platform size	1.78 x 0.84	2.1 x 1.0	2.1 x 1.2
Platform uzatma / Platform extension	800	800	800
Zemin açıklığı (teker merkezi) / Ground clearance	220	220	200
Teker mesafesi / Wheelbase	850	900	1200
Kaldırma motoru / Lifting motor	380 / 50	380 / 50	380 / 50
	1,5	1,5	2,2
Kaldırma-indirme süresi / Up-down speed	44	72	73
Voltaj / Voltage	380	380	380
	elektrikli	elektrikli	elektrikli
Arka tekerlekler / Back wheels	400 x 90	400 x 90	500 x 80
Ön tekerlekler / Front wheels	400 x 90	400 x 90	500 x 80
Ağırlık / Weight	750	1200	1500

Standard ekipmanlar

- Ayarlanabilir denge ayakları
- Mekanik durdurucu
- Acil durum indirme butonu
- Genişletilmiş platform
- Acil durum durdurma butonu
- Seviye göstergesi (su terazisi)
- Dolgu teker

Standard equipment

- Leveling outrigger device
- Safety brackets
- Emergency down button
- Extended platform
- Emergency stop button
- Leveling indicator
- Solid wheel

Elektrikli Kaldırma Manuel Yürütme

Electric Lifting Manual Travelling



- Dolgu teker



- Platform genişletme



- Arazi şartlarına uygun tekerler

- Çekici yardımıyla platform nakli

MAKASLI PLATFORM (Manuel yürütme) / SCISSOR LIFT PLATFORM

NL-MP 5011 PLUS

Platform kapasitesi / Access platform capacity	500 kg
Platform uzatma kapasitesi / S.W.L on extension	112 kg
Çalışma yüksekliği / Working height	13.5 m
Platform yüksekliği / Platform floor height	11.5 m
Makine boyu / Overall length	3.70 m
Makine genişliği / Overall width	1.68 m
Makine kapalı yüksekliği / Overall height	2.58 m
Platform ölçüsü / Platform size	2.50 x 1.12 m
Zemin açıklığı (teker merkezi) / Ground clearance	0.20 m
Teker mesafesi / Wheelbase	1.09 m
Platform genişletme ölçüsü / Platform extension size	1.27 m
Kaldırma motoru / Lifting motor	24/ 3 VDC/kW
Kaldırma-indirme süresi / Up-down speed	0.89 / 0.83 sn
Akü / Battery	4 x 6/ 210 V/Ah
Şarj cihazı / Integretad charger	24/ 25 V/A
Tekerlekler / Wheels	6.5 / 10
Ağırlık / Weight	2200 kg

Standard ekipmanlar

- Ayarlanabilir denge ayakları
- Akü şarj göstergesi
- Yüksek kapasiteli deepcycle aküler
- Mekanik durdurucu
- Forklift çepçeri
- Acil durum indirme valfi
- Genişletilebilir platform
- Acil durum durdurma butonu
- Seviye göstergesi (su terazisi)
- Aşırı yük koruma

Standard equipment

- Leveling outrigger device
- Battery charge indicator
- Deep cycle type batteries
- Safety brackets
- Forklift pockets lowering
- Emergency system
- Extended platform
- Emergency stop button
- Leveling indicator
- Over loading limitation



- Çekici yardımıyla platform nakli



- Katlanabilir korkuluk sistemi



- Yandan açılır akü hazneleri

Akülü Kaldırma Manuel Yürütme

Battery Lifting Manual Travelling



- Platform uzatma

- Mekanik durdurucu

- Arazi şartlarına uygun tekerler

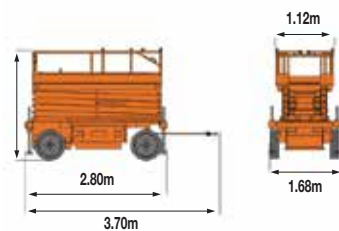

NL-MP 5011 PLUS 11.5 13.5m

MP 5011 PLUS
11.5 2.58m

AKÜLÜ MAKASLI PLATFORM / Powered SCISSOR AERIAL WORK PLATFORM

	NL-SEL 6.0 DC	NL-SEL 8.0 HD	NL-SEL 8.0 HD DAR	NL-SEL 10.0 HD	NL-SEL 12.0 HD	NL-SEL 14.0 HD	
Kaldırma kapasitesi / Capacity	230	450	230	320	320	200	kg
Platform uzatma kapasitesi / S.W.L on extension	113	113	113	113	113	113	kg
Maks. personel sayısı (platform içinde/uzatma) / Max. workers number (indoor / outdoor)	2/1	2/1	2	2/1	3	2	-
Çalışma yüksekliği / Working height (h2)	7.8	10	10	12	14	15.7	m
Platform yüksekliği / Platform height (h1)	5.8	8	8	10	12	13.7	m
Makine boyu / Overall length (L1)	1.885	2.48	2.48	2.48	2.48	2.84	m
Makine genişliği / Overall width (w1)	0.76	1.15	0.81	1.15	1.15	1.25	m
Makine yüksekliği / Overall height (rails up) (h4)	2.18	2.32	2.36	2.44	2.58	2.58	m
Makine yüksekliği (korkuluk kapalı) / Overall height (rails down) (h3)	1.78	1.78	1.93	1.92	2.04	2.17	m
Platform ölçüsü / Platform size	1.67 x 0.74	2.27 x 1.12	2.27 x 0.81	2.27 x 1.12	2.27 x 1.12	2.64 x 1.02	m
Platform uzama mesafesi / Platform extension size	0.9	0.9	0.9	0.9	0.9	0.9	m
Zemin açıklığı (kapalı) / Ground clearance (stowed)	0.07	0.10	0.10	0.10	0.10	0.10	m
Zemin açıklığı (açık) / Ground clearance (raised)	0.015	0.019	0.019	0.019	0.019	0.019	m
Teker mesafesi / Wheelbase	1.37	1.87	1.87	1.87	1.87	2.22	m
Dönme çapı / Turning radius (iç/dış, inside/outside)	1.75	2.5	2.2	2.5	2.5	2.5	m
Kaldırma motoru / Lifting motors	24-2.0	24-4.5	24-3.3	24-4.5	24-4.5	24-4.5	V / kW
Sürüş motoru / Driving motors	24-0.5	24-4.5	24-3.3	24-4.5	24-4.5	24-4.5	V / kW
Yürüyüş hızı (kapalı) / Travel speed (stowed)	4.5	3.2	3.2	3.2	3.2	3.2	km/h
Yürüyüş hızı (açık) / Travel speed (raised or extended)	0.8	0.8	0.8	0.8	0.8	0.8	km/h
Kaldırma-indirme süresi / Up-down speed	20 / 32	27/36	32/35	48 / 48	80 / 60	70 / 52	s
Akü / Battery	4 x 6 / 220	4 x 6 / 232	4 x 6 / 232	4 x 6 / 232	4 x 6 / 280	4 x 12 / 310	V / Ah
Şarj cihazı / Integretad charger	24 / 30	24 / 30	24 / 30	24 / 30	24 / 30	24 / 30	V / Ah
Tırmanma (ön/yan) / Gradeability (front/side)	25	25	25	25	25	25	%
Maksimum eğim / Maximum slope	1.5 / 3	2 / 3	1.5 / 3	2 / 3	1.5 / 3	1.5 / 3	°
Tekerlekler / Tires	Ø 305 x 100	Ø 381 x 127	Ø 381 x 127	Ø 381 x 127	Ø 381 x 127	Ø 381 x 127	mm
Ağırlık / Weight	1510	2655	2275	2890	2925	3375	kg

Art.No. 51500139

NL-SEL 6.0 DC

Art.No. 51500120

NL-SEL 8.0 HD

Art.No. 51500120-1

NL-SEL 8.0 HD DAR

Art.No. 51500121

NL-SEL 10.0 HD

Art.No. 51500019

NL-SEL 12.0 HD

Art.No. 51500020

NL-SEL 14.0 HD

Standard ekipmanlar

- Hassas kontroller
- Otomatik kilitlenen platform kapısı
- Tek yönlü platform uzatması
- Tam yükte sürüş
- İz bırakmayan tekerlek
- Hidrolik sürüş motoru(HD)
- Otomatik fren sistemi
- Acil durma indirme valfi
- Acil durdurma butonu
- Hidrolik emniyet valfi
- Arıza teşhis sistemi
- Eğitim koruma sistemi
- Eğitim alarmı
- Korna
- Çalışma saati
- Bakım güvenlik kolu
- Forklift çepeli
- Şarj koruması
- Uyarı lambası
- Katlanabilir korkuluk
- Engel koruması
- Şaşıdan ve platformdan kumanda

Opsiyonel Seçenekler

- Aşırı yük uyarısı
- Platformda elektrik prizi
- Platform çalışma aydınlatması
- Platformda hava hattı

Standard equipment

- Proportional controls
- Platform self-locking door
- One-way extension platform
- Full height travel
- Solid tire
- Hydraulic motor driving (HD)
- Automatic brakes
- Emergency lowering system
- Emergency stop button
- Oil line explosion-proof system
- Fault diagnostic system
- Inclined protection system
- Motion buzzer
- Horn
- Hour meter
- Safety maintenance support bar
- Forklift pockets
- Charger protection
- Warning beacon
- Integrated foldable guardrail
- Pot hole protection system
- Operation at chassis and platform

Options

- Overload sensor
- AC line to platform
- Platform working light
- Pneumatic line

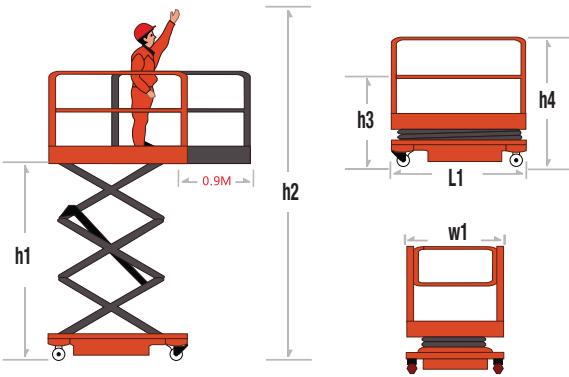

DAHİLİ ŞARJ CİHAZI INTERNAL CHARGER





Hata kodu göstergesi



Şarj Koruma Sistemi
Akü dolunca otomatik olarak şarjı sonlandırır



Kablolu joystick kumanda



İz Bırakmayan Teker



Ana Güç Anahtarı
Park halinde kapalı tutulmalıdır



Acil Durum İndirme Sistemi



Katlanabilir korkuluk



Otomatik Kilitlenen Platform Kapısı



Otomatik Fren Sistemi



Tek yönlü platform uzatma

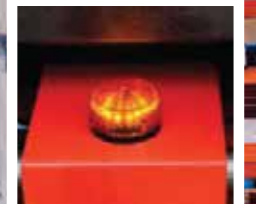

Uyarı lambası



Joystick üzerinde



Tüm komponentlere kolay erişim



NET MAK®
METAL MAKİNA SANAYİ VE TİCARET LTD. ŞTİ.

**SAC VE AHŞAP PLAKA, RULO, KİRİŞ,
RAY, BORU, VARİL, BLOK, PROFİL,
BOBİN, MAKARA VE BENZERİ
ÖZEL KALDIRMA UYGULAMALARI**

İŞ GÜVENLİĞİ YÖNETMELİKLERİNE UYGUN, SERTİFİKALI ÜRÜNLER



0850
333
4300



www.netmak.com.tr





- **Dizel Forkliftler**
Diesel Forklift Truck
- **Elektrikli Forkliftler**
Electric Forklift Truck
- **Arazi Forkliftleri**
Rough Terrain Forklift Truck
- **Ađır Hizmet Forkliftleri**
Heavy Duty Forklift Truck
- **Reach Truck**
- **Dar Koridor Aracı**
Narrow Aisle Truck
- **Konteyner Taşıma**
Container Handling Truck
- **Benzin – LPG Forkliftler**
Gasoline - LPG Forklift Truck
- **Aksesuarlar**
Accessories

FORKLİFTLER
FORKLIFTS

DİZEL FORKLİFTLER

Diesel Forklift Truck

1.8 - 12 TON
kapasite
aralıklarında



Detaylı bilgi için
www.netliftforklift.com
adresimizi ziyaret ediniz
veya QR kodu tarayınız.
For detailed information visit
www.netliftforklift.com or
scan the QR code.



ARAZİ FORKLİFTLER

Rough Terrain Forklift Truck

Detaylı bilgi için;
www.netliftforklift.com
adresimizi ziyaret ediniz.

Please visit
www.netliftforklift.com
for details technical infotmaions.



2WD

2.5 - 5 TON
kapasite
aralıklarında



Compact 4WD

1.8 - 3.5 TON
kapasite aralıklarında



4WD

2.5 - 3.5 TON
kapasite
aralıklarında



ELEKTRİKLİ FORKLİFTLER

Electric Forklift Truck

1.3 - 5 TON
kapasite
aralıklarında



Detaylı bilgi için
www.netliftforklift.com
adresimizi ziyaret ediniz
veya QR kodu tarayınız.
For detailed information visit
www.netliftforklift.com or
scan the QR code.



REACH TRUCK

1.5 - 2 TON
kapasite
aralıklarında



Detaylı bilgi için
www.netliftforklift.com
adresimizi ziyaret ediniz
veya QR kodu tarayınız.
For detailed information visit
www.netliftforklift.com or
scan the QR code.

DAR KORİDOR ARACI

Narrow Aisle Truck

1.3 - 1.5 TON
kapasite aralıklarında



AĞIR HİZMET FORKLİFTLERİ

Heavy Duty Forklift Truck
13.5 - 32 TON
kapasite
aralıklarında



Detaylı bilgi için
www.netliftforklift.com
adresimizi ziyaret ediniz
veya QR kodu tarayınız.
For detailed information visit
www.netliftforklift.com or
scan the QR code.



KONTEYNER İSTİFLEME

Reach Stacker

9 - 45 TON

kapasite aralıklarında



Detaylı bilgi için
www.netliftforklift.com
 adresimizi ziyaret ediniz
 veya QR kodu tarayınız.
 For detailed information visit
www.netliftforklift.com or
 scan the QR code.



**Dört yöne
hareket
kabiliyeti**

YANDAN YÜKLEMELİ FORKLİFT SIDE LOADER

3.5 TON

4 TON

4.5 TON

kapasitelerinde



FORKLİFT TERAZİ TARTIM SİSTEMİ / FORKLIFT TRUCK WEIGHING SCALE

Art.No. Y10530027-2

NL-Magic Forks

Özellikler / Specifications

Kapasite (taksimat) / Capacity (decimal)	2500 (1) / 3000 (1) / 5000 (2) kg
Hassasiyet / Sensivity	% 0.1
Kalibrasyon / Calibration	Sfır / Yükte / Elektronik
Aşırı yük koruması / Overload protection	% 150 FS
Haberleşme / Communication	Class 1 Bluetooth 2.1
Gösterge / Display	7" renkli LCD monitör
Tartı modları / Weighing modes	Standart / Seri / Toplam alma
Bağlantılar / Connections	RS 232c / 2x USB
Besleme gerilimi / Power supply	10-28 V / 20-72 V
Batarya / Battery	Li-ION 7.4 V / 5400 mA
Çalışma süresi / Operation period	65 saat (süreklili)



**Uzun ömürlü
Lityum-ion batarya**
Long life lithium-ion
battery



**Bluetooth teknolojisi ile
tamamen kablolu iletişim**
Wireless communication
with bluetooth technology



**İsteğe bağlı donatılan
eğim ölçme sensörü**
Optional accuracy sensor

Opsiyonel özellikler / Optional Specifications

Etiket / Label	Barkod / Özet / Detay
Bağlantı / Connection	Ethernet / Wi-Fi / Dijital 4 I/O
Çevre birimleri / Optional hardware	Eğim ölçme sensörü / RFID barkod okuyucu / Yazıcı / Harici gösterge / Tepe lambası / USB bellek / Klavye
Veri transferi / Data transfer	USB belleğe Excel dosyası / Data editör yazılımı ile PC'ye Excel dosyası / Web servis ile doğrudan SQL sunucuya anlık aktarım



- Opsiyonel barkod okuyucu entegrasyonu
- Opsiyonel barkod yazıcı entegrasyonu
- Opsiyonel USB'ye veri aktarımı
- Optional barcode handheld integration
- Optional barcode printer integration
- Optional USB data transfer



- Opsiyonel SQL sunucuya veri aktarımı
- Optional data transfer to SQL server



- Etkili güç yönetimi
- Intelligent power management



Tamamen Kablolu

- Hızlı ve kolay kurulum.
- Bir forkliftten diğerine dakikalar içinde nakil.
- Onaylı Class I, Bluetooth 2.1 + EDR kablolu teknoloji.

Wireless

- Easy and fast adaptation.
- Transfer from truck to truck in seconds
- Certified Class I, Bluetooth 2.1 + EDR wireless system



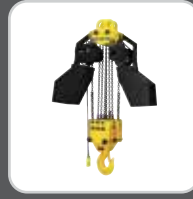

■ **Elektrikli Zincirli Vinçler**
Electric Chain Hoists

■ **Havalı Vinçler**
Air Chain Hoists

■ **Manuel, Elektrikli ve Havalı Şaryolar**
Manuel, Electric and Air Trolleys

■ **Zincirli Ceraskallar**
Chain Hoist

■ **Zincirli Çektirmeler**
Lever Hoists

■ **Halatlı Çektirmeler**
Pulling Hoists

■ **Irgatlar**
Brake Winchs

CERASKAL ve VİNÇLER
HOISTS

ELEKTRİKLİ KANCALI ZİNCİRLİ VİNÇ / ELECTRIC CHAIN HOIST WITH HOOK

	NL-D 025 H	NL-D 050 H	NL-D 100 H	
Kaldırma kapasitesi / Capacity	250	500	1000	kg
Zincir donanı / No. of column of load chain	1	2	2	sıra
Standart kaldırma yüksekliği / Lifting height	6.5	6.5	6.5	m
Kaldırma hızı / Lifting speed	8/ 2,4	4/ 1,2	4/ 1,2	m/dk
Kaldırma motoru / Lifting motor	0,36/ 0,01	0,36/ 0,01	0,76/ 0,24	kw
Voltaj / Voltage	380	380	380	V
Vinç ağırlığı / Weight	28	34	63	kg

Art.No. 52500051	NL-D 025 H
Art.No. 52500052	NL-D 050 H
Art.No. 52500053	NL-D 100 H

Not: Ray kısıkcacı opsiyonel seçenektir.
Note: Beam clamp is optional.

- Tüm modellerde kaldırma-indirme hareketi çift hızlı, yürütme tek hızlı
- In all the models lifting- lowering has double speed and travelling has single speed

- Konik rotor
- Çift hızlı
- DIN 5684 normunda zincir
- Limit şalterli (2 adet)
- Mekanik fren
- Kompakt dizayn
- Kolay servis ve bakım
- Kolay montaj ve demontaj

- Conical rotor
- Double speed
- DIN 5684 chain
- Limit switches (2 pieces)
- Mechanical brake
- Compact design
- Ease of service and maintenance
- Ease of mounting and dismounting



ELEKTRİKLİ ZİNCİRLİ VİNÇ / ELECTRIC CHAIN HOIST

	NL-S 200 H Kancalı	NL-D 200 H Kancalı	
Kapasite / Capacity	2000	2000	kg
Kaldırma hızı / Lifting speed	4	4/1	m/dk
Yürüyüş hızı / Travelling speed	-	-	m/dk
Kaldırma motoru / Lifting motor	1.5	1.5/ 0.33	kw
Yürüyüş motoru / Driving motor	-	-	kw
Zincir donanı / No of column of load chain	2	2	
Zincir çapı / Chain diameter	9 x 27	9 x 27	mm
Kaldırma yüksekliği / Lifting height	6	6	m
Profil çalışma aralığı / I - beam range	-	-	
Min. dönme yarıçapı / Min. turning radius	-	-	m
Ağırlık / Weight	135	172	kg
Voltaj / Voltage	380		V

Art.No. 52500057	NL-S 200 H
Art.No. 52500059	NL-D 200 H

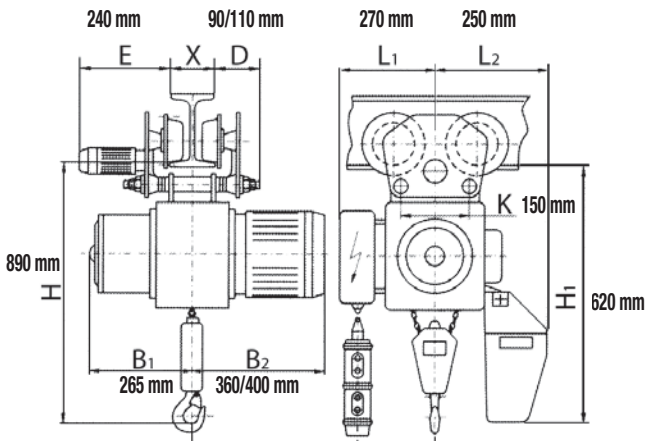

Elektrikli Şaryo / Electric Trolley (ET Serisi/ Series)

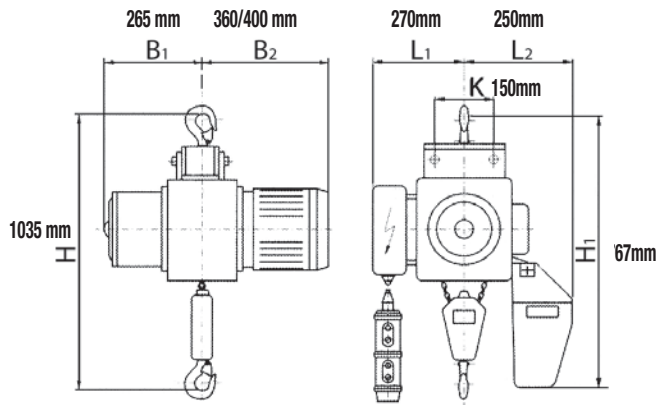

Kancalı / Upper hook (H Serisi/ Series)

ELEKTRİKLİ ZİNCİRLİ VİNÇ (NLXN) / ELECTRIC CHAIN HOIST (NLXN)

- Yükleme aralığı FEM 2m/ ISO M5' e tekabül ettiği için geniş bir uygulama alanı sağlamakta.
- Yüksek hız ile minimum hız aralığı ayarlanabilir oluşu itibarı ile kesin ve detaylı bir yükleme imkanı sunmakta.
- 48 Volt ile çalışması sonucu güvenli bir kullanım sağlamakta.
- Dayanıklı alüminyumdan üretilmiş olan zincir çantası çok sık kullanımlara uygun olarak tasarlanıp imal edilmiştir.
- Standart asmalı ürünlerimiz düz, alçak tavan ceraskal, yürütmeli arabalı ve alçak yürütme arabalı ürünlerimiz bulunmaktadır.

- Load spectrum conforms to FEM 2m/ ISO M5 covering a wide range of applications.
- Speed ratio of 4:1 clearly delineates between high speed and low speed, providing the precise load spotting capacities required in many applications.
- 48V control voltage for operator safety.
- The rugged aluminum alloy casting is engineered to withstand the rigors of repeated lifting cycles.
- Standard suspensions include Plain Trolley (PT), Low headroom Plain Trolley (LPT), Geared Trolley (GT), Low headroom Geared Trolley (LGT) and motorized Trolley.

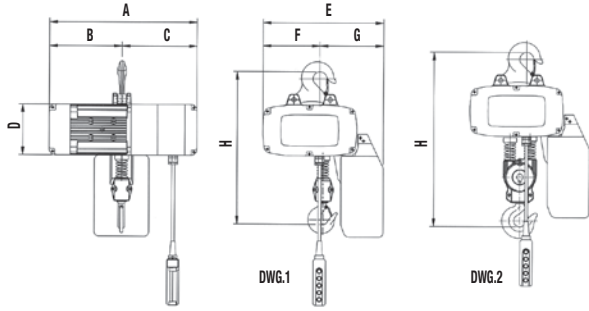

Örnek Uygulamalar / Sample Applications



İstenilen uzunlukta zincir temin edilebilmektedir.

Kod No Code No	Model	Çalışma Yük Limiti WLL (kg)	Kaldırma Yükseklği Lifting Height (m)	DWG No	Boyutlar Dimensions (mm)										Yük Zinciri Load Chain Çap x iç uzunluk Dia x pitch	Kaldırma Hızı ve Motor Gücü / Hoisting Speed and Motor Power 50Hz		Yürütme Hızı ve Motor Gücü/ Travelling Speed and Motor Power 50Hz		Enerji Energy (V/Hz)	E.D Oranı %	Donam/ Load Chain Fall No	Net Ağırlık/ Brüt Ağırlık/ N.W/G. W (kg)
					A	B	C	D	E	F	G	H	Çift Hız/ Dual Spd. m / dk	Motor Gücü/ Motor Power kw		Çift Hız/ Dual Spd. m / dk	Motor Gücü/ Motor Power kw						
71301251	NLXN-251	250	3	1	380	175	205	135	299	143	156	376	Φ 4.0x12.0	12/2.7	0.6/0.15	20/5	0.12/0.03	380/50	40/20	1	30/ 42		
71301502	NLXN-502	500	3	2	380	175	205	135	299	143	156	453	Φ 4.0x12.0	6/1.3	2/8P	20/5	2/8P	380/50	40/20	2	32/ 44		
71301501	NLXN-501	500	3	1	468	221	247	156	366	186	180	485	Φ 6.3x19.1	10/2.5	1.1/0.28	20/5	0.18/0.04	380/50	40/20	1	42/ 57		
71311002	NLXN-1002	1000	3	2	468	221	247	156	366	186	180	531	Φ 6.3x19.1	5/1.25	2/8P	20/5	2/8P	380/50	40/20	2	45/ 60		
71311001	NLXN-1001	1000	3	1	488	240	248	170	398	188	210	520	Φ 7.1x20.2	8/2	1.5/0.37	20/5	0.37/0.09	380/50	40/20	1	57/ 77		
71312002	NLXN-2002	2000	3	2	488	240	248	170	398	188	210	592	Φ 7.1x20.2	4/1	2/8P	20/5	2/8P	380/50	40/20	2	62/ 82		

ELEKTRİKLİ ŞARYO (NLXT) / ELECTRIC TROLLEY (NLXT)

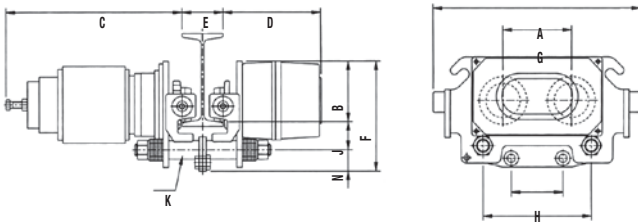
ELEKTRİKLİ ŞARYO (NLXT) /
ELECTRIC TROLLEY (NLXT)

Kod No Code No	Model	Boyutlar / Dimensions (mm)											Hız Speed (m / dk)	Motor (m / dk)	Enerji Energy (V/Hz)	Net Ağırlık/ N.W (kg)	Min Dönüş Radyusu/ Min. radius curve (m)				
		A	B	C	D	E	F	G	H	L	J	N						K			
71401501	NLXT-0501																				
71420501	NLXTD-0501	382	111.5	324	180	75-125	202	125.5	95.5	200	51.5	39	7/8"-9UNC (φ22.2)	20/5	0.12 - 2P	380/50	45	1.3			
71401502	NLXT-0502																				
71420502	NLXTD-0502	382	111.5	324	180	75-125	204	125.5	120	200	51.5	41	7/8"-9UNC (φ22.2)	20/5	0.12 - 2P	380/50	45	1.3			
71411001	NLXT-1001																				
71421001	NLXTD-1001	382	111.5	324	180	75-125	202	125.5	120	200	51.5	39	7/8"-9UNC (φ22.2)	20/5	0.18 - 2P	380/50	45	1.3			
71411002	NLXT-1002																				
71421002	NLXTD-1002	382	111.5	324	180	75-125	202	125.5	95.5	200	51.5	39	7/8"-9UNC (φ22.2)	20/5	0.18 - 2P	380/50	45	1.3			
71412002	NLXT-2002																				
71422002	NLXTD-2002	392	125	357	183	100-150	221	159	120	230	60	36	1"-8UNC (φ25.4)	20/5	0.37 - 2P	380/50	50	1.7			



ELEKTRİKLİ ZİNCİRLİ VİNÇ (Classic) / ELECTRIC CHAIN HOIST (Classic)

* Dual Speed E.D Rating: 40/ 120 * Çift Hız E.D Oranı: 40/ 120

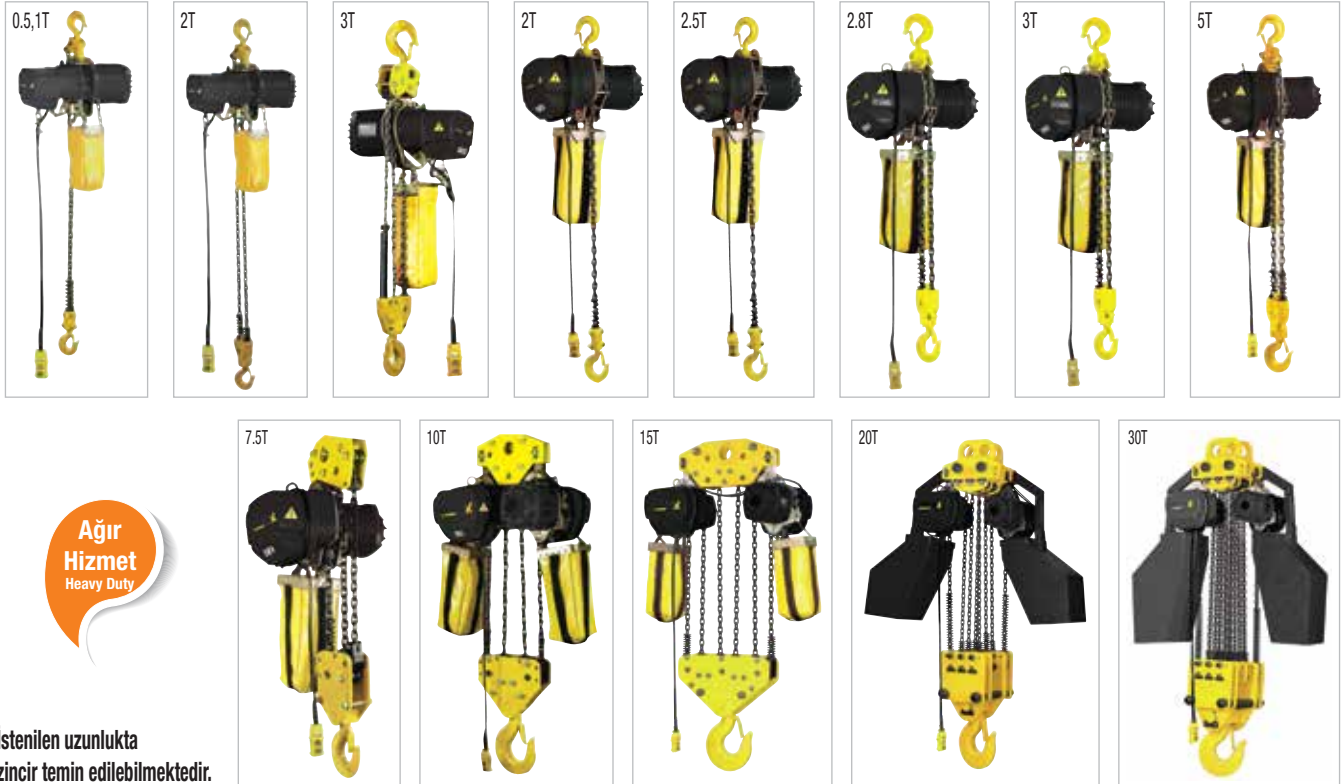

Ağır Hizmet
Heavy Duty

İstenilen uzunlukta zincir temin edilebilmektedir.

Kod No Code No	Model	Kaldırma Kapasitesi Lifting Capacity (SWL)	Kaldırma Hızı Lifting Speed (m / dk)	Zincir Çapı Chain Diam. (mm)	Zincir Donanı Load Chain Fall No	Kaldırma Yüksekliği Lifting Height (m)	Motor Gücü Motor Power (kw)	E.D. Oranı E.D Rating (%)	Enerji/ Energy (V)	Ağırlık Weight (kg)	Ambalaj Boyutları Packaging LxWxH (cm)
71100500	NSL050	0,5t	6,7	7,1	1	3 m	1,8	40	380 / 50 Hz	55	60 x 57 x 33
71100501	NSH050	0,5t	9,2	7,1	1	3 m	1,8	40	380 / 50 Hz	55	60 x 57 x 33
71100506	NSLD050	0,5t	6,7 / 2,2	7,1	1	3 m	1,8 / 0,6	40	380 / 50 Hz	55	60 x 57 x 33
71100507	NSHD050	0,5t	9,2 / 3,1	7,1	1	3 m	1,8 / 0,6	40	380 / 50 Hz	55	60 x 57 x 33
71100503	NSF050	0,5t	6,7	7,1	1	3 m	1,8	15	220 / 50 Hz	55	60 x 57 x 33
71101000	NSL100	1t	4,7	7,1	1	3 m	1,8	40	380 / 50 Hz	55	60 x 57 x 33
71101001	NSH100	1t	6,7	7,1	1	3 m	1,8	40	380 / 50 Hz	55	60 x 57 x 33
71101006	NSLD100	1t	4,7 / 1,6	7,1	1	3 m	1,8 / 0,6	40	380 / 50 Hz	55	60 x 57 x 33
71101007	NSHD100	1t	6,7 / 2,2	7,1	1	3 m	1,8 / 0,6	40	380 / 50 Hz	55	60 x 57 x 33
71101003	NSF100	1t	6,7	7,1	1	3 m	1,8	15	220 / 50 Hz	55	60 x 57 x 33
71102000	NSL200	2t	2,3	7,1	2	3 m	1,8	40	380 / 50 Hz	61	60 x 57 x 33
71102001	NSH200	2t	3,3	7,1	2	3 m	1,8	40	380 / 50 Hz	61	60 x 57 x 33
71102014	NSLD200	2t	2,3 / 0,8	7,1	2	3 m	1,8 / 0,6	40	380 / 50 Hz	61	60 x 57 x 33
71102009	NSHD200	2t	3,3 / 1,1	7,1	2	3 m	1,8 / 0,6	40	380 / 50 Hz	61	60 x 57 x 33
71102004	NSF200	2t	2,3	7,1	2	3 m	1,8	15	220 / 50 Hz	61	60 x 57 x 33
71103000	NSL300	3t	1,5	7,1	3	3 m	1,8	40	380 / 50 Hz	73	62 x 62 x 50
71103001	NSH300	3t	2,2	7,1	3	3 m	1,8	40	380 / 50 Hz	73	62 x 62 x 50
71103002	NSLD300	3t	1,5 / 0,5	7,1	3	3 m	1,8 / 0,6	40	380 / 50 Hz	73	62 x 62 x 50
71103003	NSHD300	3t	2,2 / 0,7	7,1	3	3 m	1,8 / 0,6	40	380 / 50 Hz	73	62 x 62 x 50
71102010	NSSD200	2t	6,6 / 2,2	10	1	3 m	3,7 / 1,2	40	380 / 50 Hz	125	73 x 57 x 41
71102002	NSS200	2t	6,6	10	1	3 m	3,7 / 1,2	40	380 / 50 Hz	125	73 x 57 x 41
71102500	NSS250	2,5t	5,2	11,2	1	3 m	3,7	40	380 / 50 Hz	130	73 x 57 x 41
71102501	NSSD250	2,5t	5,2 / 1,7	11,2	1	3 m	3,7 / 1,2	40	380 / 50 Hz	130	73 x 57 x 41
71103004	NSS300	3t	4,3	10	2	3 m	3,7	40	380 / 50 Hz	140	73 x 57 x 41
71103005	NSSD300	3t	4,3 / 1,4	10	2	3 m	3,7 / 1,2	40	380 / 50 Hz	140	73 x 57 x 41
71105000	NSS500	5t	2,6	11,2	2	3 m	3,7	40	380 / 50 Hz	153	73 x 57 x 41
71105001	NSSD500	5t	2,6 / 0,9	11,2	2	3 m	3,7 / 1,2	40	380 / 50 Hz	153	73 x 57 x 41
71107500	NSS750	7,5t	1,8	11,2	3	3 m	3,7	40	380 / 50 Hz	195	73 x 57 x 41
71107501	NSSD750	7,5t	1,8 / 0,6	11,2	3	3 m	3,7 / 1,2	40	380 / 50 Hz	195	73 x 57 x 41
71110000	NSS1000	10t	2,6	11,2	4	3 m	3,7 x 2	40	380 / 50 Hz	410	86 x 85 x 75
71110001	NSSD1000	10t	2,6 / 0,9	11,2	4	3 m	3,7x2 / 1,2x2	40	380 / 50 Hz	410	86 x 85 x 75
71115000	NSS1500	15t	1,8	11,2	6	3 m	5 x 2	40	380 / 50 Hz	510	140 x 85 x 97
71115001	NSSD1500	15t	1,8 / 0,6	11,2	6	3 m	5x2/1,7x2	40	380 / 50 Hz	510	140 x 85 x 97
71120000	NSS2000	20t	1,3	11,2	8	3 m	5 x 2	40	380 / 50 Hz	890	170x105x167
71120001	NSSD2000	20t	1,3 / 0,43	11,2	8	3 m	5x2/1,7x2	40	380 / 50 Hz	890	170x105 x167
71130000	NSS3000	30t	0,9	11,2	12	3 m	5 x 2	40	380 / 50 Hz	1035	170x105x167
71130001	NSSD3000	30t	0,9 / 0,3	11,2	12	3 m	5x2/1,7x2	40	380 / 50 Hz	1035	170x105x167

Ölçüler / Dimensions

Model	Kapasite Capacity (ton)	Boyutlar Dimensions (mm)												
		H (mm)	A (mm)	B (mm)	C (mm)	D (mm)	E (mm)	F (mm)	I (mm)	J (mm)	K (mm)	L (mm)	M (mm)	N (mm)
NSL050, NSH050, NSLD050, NSHD050, NSF050	0.5	570	505	245	260	240	115	125	40	28	40	28	23	23
NSL100, NSH100, NSLD100, NSHD100, NSF100	1	570	505	245	260	240	115	125	40	28	40	28	23	23
NSL200, NSH200, NSLD200, NSHD200, NSF200	2	700	505	245	260	240	175	65	46	36	46	36	31	31
NSL300, NSH300, NSLD300, NSHD300	3	880	505	245	260	280	175	105	52	43	52	43	34	34
NSSD200, NSS200,	2	835	640	326	314	448	278	170	52	43	52	43	34	34
NSS250, NSSD250	2.5	880	640	326	314	448	278	170	52	43	52	43	34	34
NSS300, NSSD300	3	960	640	326	314	448	340	108	52	43	52	43	34	34
NSS500, NSSD500	5	1030	640	326	314	448	356	92	62	45	62	45	45	45
NSS750, NSSD750	7.5	1050	640	326	314	587	388	199	72	40	75	57	84	48
NSS1000, NSSD1000	10	1270	640	326	314	970	485	485	72	40	100	68	92	60
NSS1500, NSSD1500	15	1365	640	326	314	1360	680	680	80	40	120	90	169	85
NSS2000, NSSD2000	20	1700	866	433	433	1472	736	736	82	82	140	95	164	95
NSS3000, NSSD3000	30	1700	924	462	462	1472	736	736	92	92	140	95	221	95

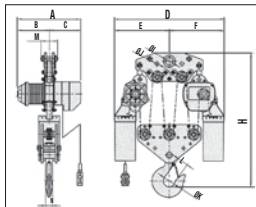
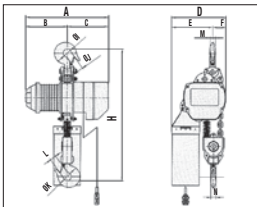
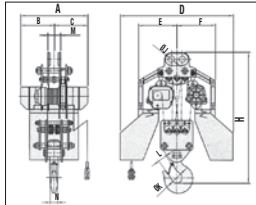
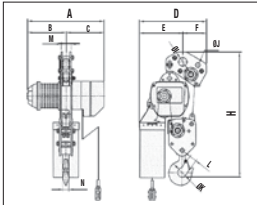
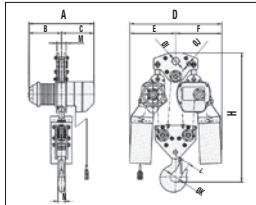
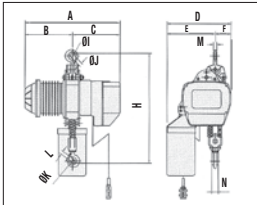

"Netlift BLACX" Elektrikli Vinçlerin Avantajları:

- 24/48 volta dönüştürülmüş elektrik akımı özellikle nemli bölgelerde yanlış kullanımlarda anında müdahale imkanı vermekte.
- Otomatik fren sistemi ani elektrik kesintilerinde veya ürünün kapanmasında anında fren sistemi devreye girmekte.
- İkili fren sistemi daha emniyetli bir kullanım sağlamakta.
- Limit dü mesi zincirin gereksiz yer boşalmasını engellemekte.
- İleri teknoloji hata tespit röleleri motoru yanlış elektrik akımlarında korumaya alıp, hareket ettirmemekte.
- Acil durum freni opsiyonel olarak mevcuttur.
- Elektronik aşırı yüklenme koruması opsiyonel olarak mevcuttur.

"Netlift BLACX" Advantages of Electric Chain Hoist:

- Pendant control voltage transformed into 24V/48V to eliminate possible accident caused by circuit short and assure safe operation in wet environments.
- Automatic motor brake system features simultaneous braking upon power failure or switching off.
- Dual brake system assures safe operation.
- Limit switches hold chain from running out.
- Advanced phase error relay keeps motor motionless at incorrect power connection
- Optional emergency stop features available.
- Optional electronic overload protection available.

ELEKTRİKLİ ŞARYO (Classic MT) /
ELECTRIC TROLLEY (Classic MT)

ELEKTRİKLİ ŞARYO (Classic MT) / ELECTRIC TROLLEY (Classic MT)

Kod No Code No	Model	Kapasite Capacity (ton)	Flanş Genişliği Flange Width (E)	Hız Speed (m / dk)	Motor (kw)	Enerji Energy	Kutup Pole (kw)	Min. Dönüş Çapı Min. Radius (m)	Ağırlık Weight (kg)
712 01 000	MT-100	1	75-125	20	0,25	380 V / 50Hz	4,6	1,3	40
712 01 003	MTD-100	1	75-125	20/7	0,25/0,08	380 V / 50Hz	4/12	1,3	40
712 01 002	MTF-100	1	75-125	20	0,25	220 V / 50Hz	4,6	1,3	40
712 02 000	MT-200	2	100-150	20	0,25	380 V / 50Hz	4,6	1,5	45
712 02 003	MTD-200	2	100-150	20/7	0,25/0,08	380 V / 50Hz	4/12	1,5	45
712 02 002	MTF-200	2	100-150	20	0,25	220 V / 50Hz	4,6	1,5	45
712 03 000	MT-300	3	125-175	20	0,6	380 V / 50Hz	4,6	1,8	65
712 03 001	MTD-300	3	125-175	20/7	0,6/0,2	380 V / 50Hz	4/12	1,8	65
712 05 000	MT-500	5	125-175	20	0,6	380 V / 50Hz	4,6	2,0	89
712 05 001	MTD-500	5	125-175	20/7	0,6/0,2	380 V / 50Hz	4/12	2,0	89
712 07 500	MT-750	7.5	150-200	13	0,9	380 V / 50Hz	6	3,0	155
712 07 501	MTD-750	7.5	150-200	13/ 6,5	0,9/0,45	380 V / 50Hz	6/12	3,0	155
712 10 000	MT-1000	10	150-200	14	1,5	380 V / 50Hz	6	3,5	218
712 10 001	MTD-1000	10	150-200	14/7	1,5/0,75	380 V / 50Hz	6/12	3,5	218
712 15 000	MT-1500	15	190	10	1,5	380 V / 50Hz	6	-	350
712 15 001	MTD-1500	15	190	10/5	1,5/0,75	380 V / 50Hz	6/12	-	350
712 20 000	MT-2000	20	200	12	2,2	380 V / 50Hz	4	-	575
712 20 001	MTD-2000	20	200	12/4	2,2/0,73	380 V / 50Hz	4/12	-	575
712 30 000	MT-3000	30	200	12	2,2	380 V / 50Hz	-	-	-
712 30 001	MTD-3000	30	200	12/4	2,2/0,73	380 V / 50Hz	-	-	-

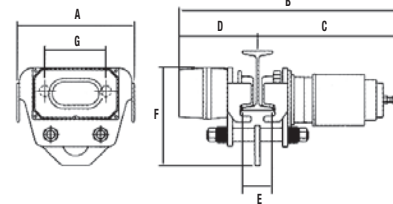

Ölçüler / Dimensions

Kapasite Capacity (ton)	Boyutlar Dimensions					
	A (mm)	B (mm)	C (mm)	D (mm)	F (mm)	G (mm)
1	295	541	345	196	246	149
2	323	567	358	209	272	161
3	359	662	417	245	297	172
5	389	673	422	251	320	183
7.5	454	736	465	271	530	228.3
10	560	821	550	271	565	277.3
15	692	878	589	289	530	353
20	882	1025	719	306	604	439.6

NOT: MT modeli tek hız, MTD modeli çift hızdır.

ALÇAK TAVAN VİNCİ - ELEKTRİK ŞARLOYU / HEADROOM HOIST - ELECTRIC TROLLEY

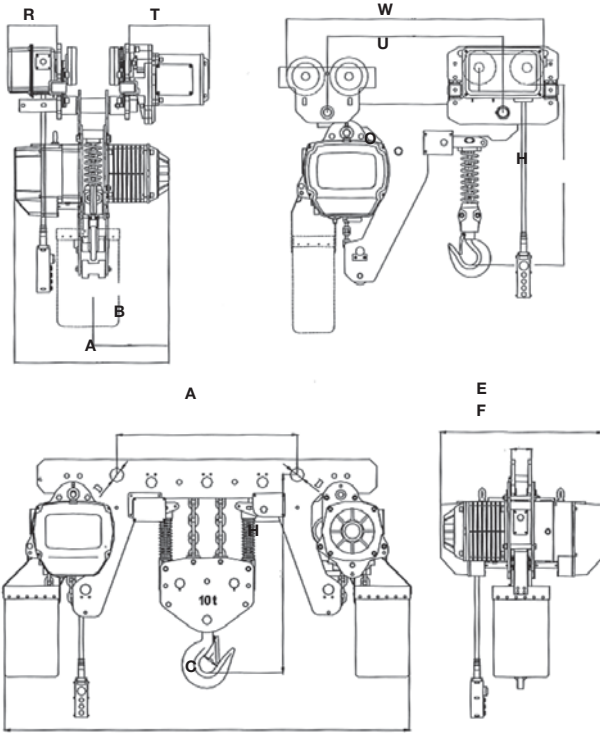

Alçak Tavan
Low Headroom

Kod No Code No	Model	Kapasite Capacity (ton)	Kaldırma Hızı min./max. Lifting Speed min./max (m / dk)	Motor Gücü Motor power (kw)	Rotasyon Hızı Rotation speed (r/min)	Güç Kaynağı Power Supply	Voltaj Voltage (V)	Kaldırma Yüksekliği Lifting Height (m)	Donam No of chain	Zincir Çapı Chain Diam. (mm)	Boyutlar / Diemensions (mm)				
											H	A	B	W	U
71100504	NL-SSDHL 0.5-01	0.5	7.2 / 2.4	0.8 / 0.27	2880 / 960	3P 380V	24 / 36 / 48	5	1	Ø 6.3	400	545	260	585	400
71101004	NL-SSDHL 0.1-01	1	6.9 / 2.3	1.8 / 0.6					1	Ø 7.1	480	582	280	630	445
71101504	NL-SSDHL 1.5-01	1.5	9.0 / 3.0	3.0 / 1.0					1	Ø 10.0	570	670	313	720	505
71102005	NL-SSDHL 2.0-01	2	6.9 / 2.3	3.0 / 1.0					1	Ø 10.0	570	670	313	720	505
71102008	NL-SSDHL 2.0-02	2	3.3 / 1.1	1.8 / 0.6					2	Ø 7.1	535	582	280	665	445
71102505	NL-SSDHL 2.5-01	2.5	5.4 / 1.8	3.0 / 1.0					1	Ø 11.2	640	670	313	775	526
71103007	NL-SSDHL 3.0-01	3	5.4 / 1.8	3.0 / 1.0					1	Ø 11.2	640	670	313	775	526
71103008	NL-SSDHL 3.0-02	3	4.5 / 1.5	3.0 / 1.0					2	Ø 10.0	685	670	313	750	503
71105002	NL-SSDHL 5.0-02	5	2.7 / 0.9	3.0 / 1.0					2	Ø 7.1	740	670	313	825	541
71107503	NL-SSDHL 7.5-03	7.5	1.8 / 0.6	3.0 / 1.0					3	Ø 11.2	890	670	313	1020	730
71110004	NL-SSDHL 10.0-04	10	2.7 / 0.9	3.0 / 1.0	4	Ø 11.2	850	670	313	996	700				

* Tek hızlı seçenekleri mevcuttur.

ELEKTRİK ŞARYO ÖLÇÜLERİ / ELECTRIC TROLLEY DIMENSIONS

Kapasite Capacity (ton)	Boyutlar / Diemensions (mm)				Hız Speed min./max (m / dk)	Motor Motor (kw)	Min. Dönme çapı Min. radius of turn
	W	U	R	T			
0.5	315	212	142	231	21	0.4	0.8
1	315	212	142	231		0.4	0.8
2	325	220	142	231		0.4	0.9
3	340	250	142	231		0.75	1.0
5	400	291	142	231		0.75	1.5
7.5	400	291	142	231		0.75	1.8
10	500	371	142	231		0.75	2.0

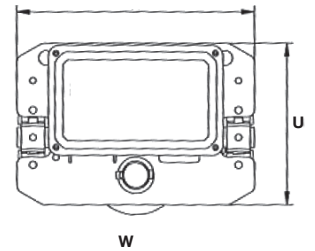
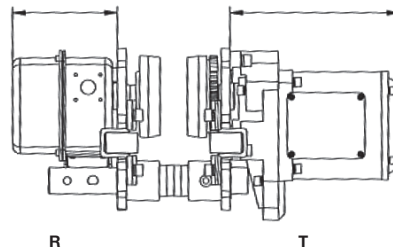

HAVALI ZİNCİRLİ VİNÇ / AIR CHAIN HOIST

Kod No Code No	Model	Kapasite Capacity (kg)	Kaldırma Yükseklği Lifting Height (m)	Sınıflandırma Classification	Çalıştırma Operation	Motor (kw)	Hava Basıncı Air Supply Pressure (kg/cm ²)	Donam no Fall no.	Yük zinciri Load Chain (mm)	Hız Speed (m/dk)	Hava Tüketimi Air Consumption (m ³ / dk)	Yalıtım Korunması Insulation protection	Fren Tipi Brake Type	Anahtar Limit Switch	Hava Giriş Air Inlet (in)	Gürültü Seviyesi Level of Noise (dB)	Ana Hava Tedarik Hatlı Main Line Air Supply
71100525	NSA-025	250	3	FEM 2m	Zincirli kontrol veya pendente kontrol/ Toggle control or pendant control	1.5	6 (85PSI)	1	6.3 x 19.1	18	2	IP 54	Disk Fren/ Disk type brake	Üst / Alt Limit/ Upper / lower limit	1/2"	85	3/4"
71100526	NSA-050	500				1		6.3 x 19.1	11	2	1/2"				85	3/4"	
71100527	NSA-100	1000				1		7.1 x 20.2	7.6	2	1/2"				85	3/4"	
71100528	NSA-200	2000				2		7.1 x 20.2	3.8	2	1/2"				85	3/4"	
71100529	NSA-320	3200				1		13 x 36	4.8	4	3/4"				90	2"	
71100530	NSA-630	6300				2		13 x 36	2.4	4	3/4"				90	2"	

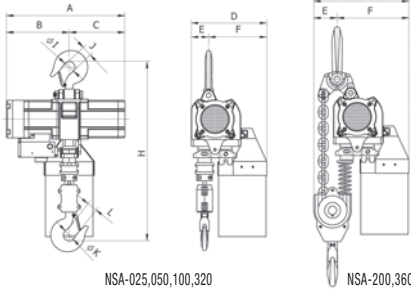

NSA-025,050,100,320

NSA-200,360

Ölçüler / Dimensions

Kapasite Capacity (kg)	Boyutlar Dimensions										
	H (mm)	A (mm)	B (mm)	C (mm)	D (mm)	E (mm)	F (mm)	I (mm)	J (mm)	K (mm)	L (mm)
250	493	350	176	174	227	50	177	40	32	40	32
500	493	350	176	174	227	50	177	40	32	40	32
1000	522	433	228.5	204.5	247	55	192	40	32	40	32
2000	652	433	288.5	204.5	325	73	252	46	40	46	40
3200	792	523.5	277.5	246	334	77	257	52	47	52	47
6300	1013	523.5	277.5	246	421	104	317	62	52	62	52

HAVALI ŞARYO / AIR TROLLEY

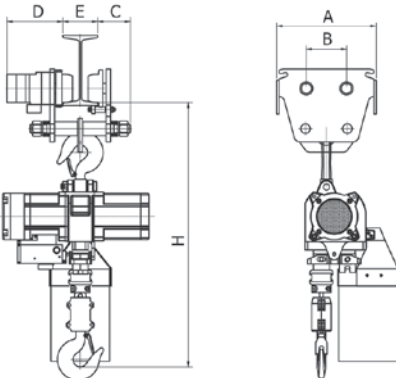

HAVALI ŞARYO / AIR TROLLEY

Kod No Code No	Şaryo Modeli Trolley model	Kapasite Capacity (kg)	Motor (kw)	Hava Basıncı Air supply pressure (kg/cm ²)	Gezdirme Traversing (m/ dk)	Fren Tipi Brake type	Hava Giriş Air inlet (in)
71400500	AT 100	1000	0.2	6	16	Disk tipi fren/ Disk type brake	5/16"
71400501	AT 200	2000	0.2	6	16	Disk tipi fren/ Disk type brake	5/16"
71400502	AT 320	3200	0.2	6	16	Disk tipi fren/ Disk type brake	5/16"
71400503	AT 630	6300	0.2	6	8	Disk tipi fren/ Disk type brake	5/16"

HAVALI VİNÇ ve ŞARYO KOMBİNASYONU- ÖLÇÜLER /
COMBINATION OF AIR CHAIN HOIST AND AIR TROLLEY

Model	Kapasite Capacity (kg)	Boyutlar Dimensions					
		H (mm)	A (mm)	B (mm)	C (mm)	D (mm)	E (mm)
NSA-025 + PT 050*	250	608	194	89	35	-	50-150
NSA-050 + PT 050*	500	608	194	89	35	-	50-150
NSA-100 + AT 100	1000	645.5	294	116	95	208	75-125
NSA-200 + AT 200	2000	785.5	322	135	100	209.5	100-150
NSA-320 + AT 320	3200	945	356	144	117.5	217	125-175
NSA-630 + AT 630	6300	1168	386	183	132.5	219	125-175

* Manuel Şaryo / Plain Trolley

ZİNCİRLİ CERASKAL (BLACX AĞIR HİZMET ZİNCİRLİ CERASKALLARI) / CHAIN HOIST (BLACX HEAVY DUTY CHAIN HOIST)

Kod No Code No	Model	Kapasite Capacity (ton)	S.W.L Güvenli Çalışma Yüklü Safe Working Load (kg)	Test Yüklü Test Load (ton)	Standart Kaldırma Yüksekliliği Standard Lifting Height (m)	Yük Zinciri Çapı Load Chain Diameter (mm)	Yük Zincir Donanı Load Chain Fall	Çekme Gücü Pulling Efforts (kg)	Ceraskal Yüksekliliği Head Room (mm) (G)	Net Ağırlık Net Weight (kg)	Brüt Ağırlık Gross Weight (kg)
71700005 71700005-1	BX-0.5 BX-0.5 yük limitörlü	0.5	500	0.75	5	6.3	1	21	305	10.3	10.8
71700100 71700100-1	BX-1 BX-1 yük limitörlü	1	1000	1.50	5	6.3	1	25	340	11.1	11.7
71700150 71700150-1	BX-1.5 BX-1.5 yük limitörlü	1.5	1500	2.25	5	7.1	1	32	385	15.5	16.3
71700200 71700200-1	BX-2 BX-2 yük limitörlü	2	2000	3.0	5	8.0	1	34	420	19.7	20.6
71700300 71700300-1	BX-3 BX-3 yük limitörlü	3	3000	4.50	5	7.1	2	34	465	23.4	24.4
71700301 71700302	BX-3 / 1 BX-3/ 1	3	3000	4.50	5	10	1	38	550	30.7	32.3
71700500 71700500-1	BX-5 BX-5 yük limitörlü	5	5000	7.5	5	8.0	3	37	575	37.8	39.6
71701000	BX-10	10	10000	15	5	10	3	40	660	69.3	73.2

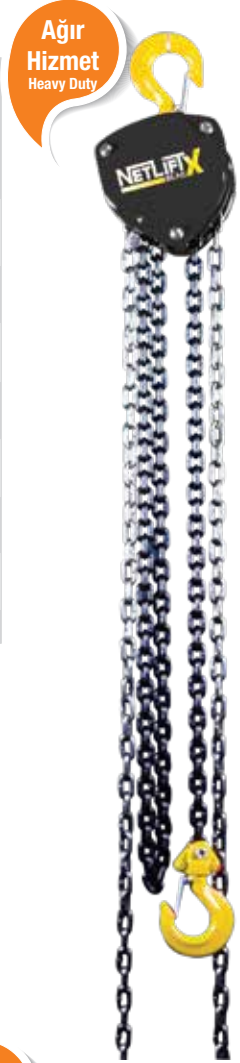

Kapasite Capacity (ton)	Boyutlar Dimensions							
	A (mm)	B (mm)	D (mm)	E (mm)	N (mm)	F (mm)	F1 (mm)	G (mm)
1.50	89	67	50	80	2650	30	26	305
1	89	67	63	87	2660	33	28	340
1.5	93	73	75	105	2660	38	34	385
2	98	77	85	115	2665	43	38	420
3	93	73	60	150	2675	43	38	465
5	98	77	120	210	2750	57	52	575

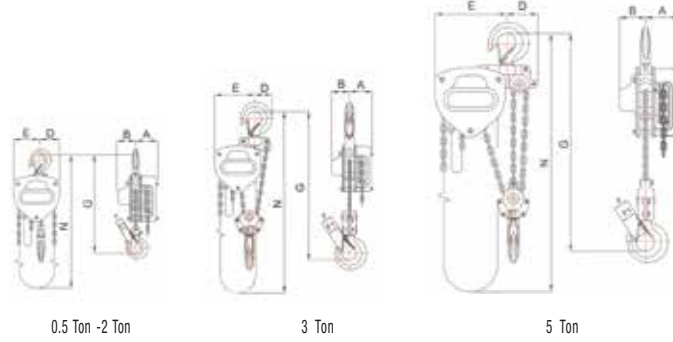

ZİNCİRLİ ÇEKTİRME (BLACX AĞIR HİZMET ZİNCİRLİ ÇEKTİRMELER) / LEVER HOIST (BLACX HEAVY DUTY LEVER HOIST)

Kod No Code No	Model	Kapasite Capacity (ton)	Çektirme mesafesi Pulling Distance (m)	Test Yüklü Test Load (kg)	Tam Yükle Harcanan Efor Pull On Lever To Lift Full Load (kg)	Yük Zinciri Çapı Load Chain Diameter (mm)	Zincir Donanı Load Chain Fall No	Net Ağırlık Net Weight (kg)	Brüt Ağırlık Gross Weight (kg)
71710025	BXL-0.25	1/4	1.0	250	30	F 4.0	1	2	2.15
71710050	BXL-0.5	1/2	1.0	500	34	F 0.5	1	3.6	3.9
71710075 71710075-1	BXL-0.75 BXL-0.75 yük limitörlü	3/4	1.5	1125	22	F 6.3	1	6.9	7.38
71710100 71710100-1	BXL-1 BXL-1 yük limitörlü	1	1.5	1500	29	F 6.3	1	7.2	7.68
71710150 71710150-1	BXL-1.5 BXL-1.5 yük limitörlü	1/1.2	1.5	2250	26	F 7.1	1	10	10.75
71710300 71710300-1	BXL-3 BXL-3 yük limitörlü	3	1.5	4500	38	F 10	1	17.7	18.85
71710600 71710600-1	BXL-6 BXL-6 yük limitörlü	6	1.5	9000	40	F 10	2	28.1	30.1
71711000 71711000-1	BXL-10 BXL-10 yük limitörlü	10	1.5	10000	46	F 10	3	43	46.3

Kapasite Capacity (ton)	Boyutlar Dimensions						
	A (mm)	B (mm)	C (mm)	D (mm)	E (mm)	F (mm)	F1 (mm)
0.25	60	156	245	82	63	27	22
0.5	75	276	270	100	75	30	26
0.75	128	240	275	158	99	30	26
1	128	240	295	158	99	34	30
1.5	154	360	320	172	104	38	34
3	182	360	400	195	108	43	38
6	242	360	570	195	108	57	52

- Sağlam çelik gövde.
- Hafif, kompakt ve portatif.
- Darbelere dayanıklı.
- 360 derece dönebilen kol.
- Kullanımı kolay.
- Toz ve suya karşı tamamen korumalı.
- Tek elle kullanılabilme özelliği.
- Çift mandallı güvenli fren sistemi.
- Alaşım zincir ve kanca.

- Rugged steel body construction.
- Light weight, compact and portable.
- Impact resistant.
- 360 degree handle rotation.
- Short stroke and low lever pull effort.
- Fully sealed and protect against damage from dust and water.
- Easy single-hand "Free chaining" operation.
- Safe, reliable mechanical brake system with two, brake pawls.
- High - tensile alloy chain and hooks

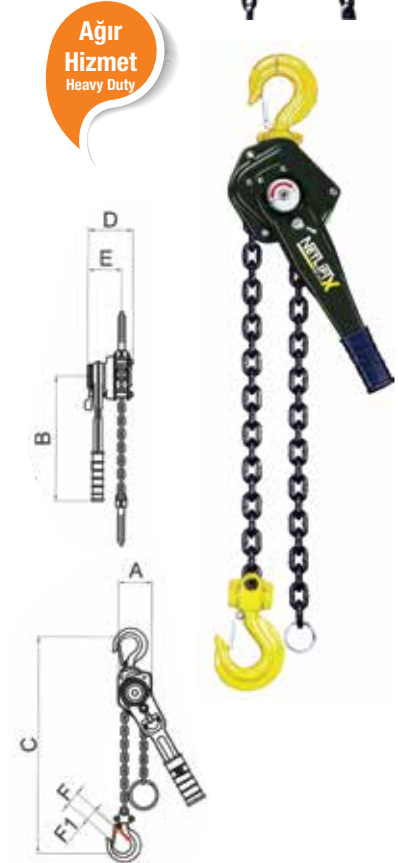

0.5 Ton

AYARLANABİLİR MANUEL ŞARYO / MANUEL ADJUSTABLE PLAIN TROLLEY

Kod No Code No	Model Düz Şaryo Model Plain Trolley	Kapasite Capacity (ton)	Ayarlanabilir İz Genişliği Track Widths Range 1 (mm)	Ölçüler / Dimensions (mm)										Min.Dönüş Radyusu Min.Curve Radius (m)	Net Ağırlık Net Weight (kg)
				A	A+	B	C	E	F	G	H	J	K		
7180005	BXP-0.5	0.5	62 - 128	195	235	106	106	98	20	64	10	24	30	0.8	5
71800100	BXP-1	1	62 - 128	213	253	113	113	106	20	71	10	27	34	1.0	7.5
71800200	BXP-2	2	88 - 154	236	284	136	136	132	25	80	13	38	46	1.3	12
71800300	BXP-3	3	87 - 153	270	318	146	146	150	25	97	13	42	53	1.5	19.5
71800500	BXP-5	5	106 - 194	323	371	169	169	174	30	117	16	46	59	1.5	30.5
71801000	BXP-10	10	125 - 320	346	394	237	236	210	40	117	-	-	-	1.5	135.5

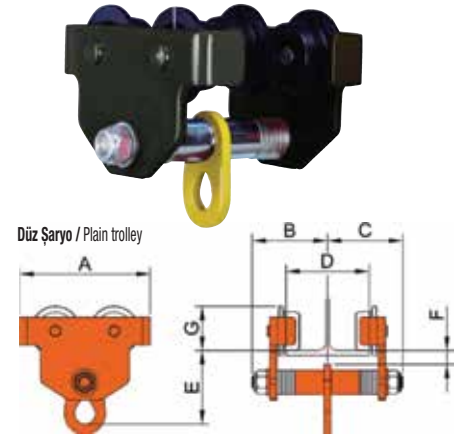

Düz Şaryo / Plain trolley

AYARLANABİLİR ZİNCİRLİ ŞARYO / MANUEL ADJUSTABLE CHAIN TROLLEY

Kod No Code No	Model Zincirli Şaryo Model Chain Trolley	Kapasite Capacity (ton)	Ayarlanabilir İz Genişliği Track Widths Range 1 (mm)	Ölçüler / Dimensions (mm)										Min.Dönüş Radyusu Min.Curve Radius (m)	Net Ağırlık Net Weight (kg)
				A	A+	B	C	E	F	G	H	J	K		
71810005	BXG-0.5	0.5	62 - 203	195	235	179	106	98	20	64	10	24	30	0.8	9
71810100	BXG-1	1	62 - 203	213	253	180	113	106	20	71	10	28	34	1.0	11
71810200	BXG-2	2	88 - 230	236	284	194	136	132	25	80	12	38	46	1.3	16.5
71810300	BXG-3	3	87 - 230	270	318	197	146	150	25	97	13	42	52	1.5	24.5
71810500	BXG-5	5	106 - 305	323	371	216	169	174	30	117	16	46	60	1.5	35.5
71811000	BXG-10	10	125 - 320	346	394	282	243	210	40	117	-	-	-	1.5	78

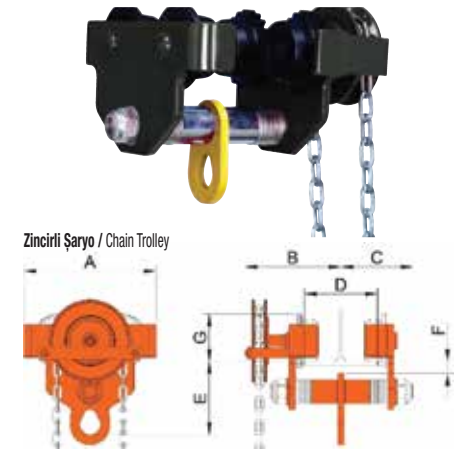

Zincirli Şaryo / Chain Trolley

Netlift Blac Rulmanlı Şaryolar

- Netlift Blac şaryolar kolay ve düzgün hareket imkanı sağlar.
- Hem elektrikli hem manuel ceraskallar için kullanılabilir.
- Güvenlik katsayısı 5'tir.
- Rulmanlı tekerler kolay ve düzgün hareket imkanı sağlar.
- Ekstra güvenlik sağlayan dizayn sayesinde tekerler ray sonlarındaki tutuculara çarpma bile zarar görmesini engeller.

Netlif Ball Bearing Trolley

- Netlif trolleys are designed to provide smooth and easy traversing.
- The 5:1 design factor allows the Netlift trolleys to be used with both manual or powered hoists.
- The Anti-Drop plates design ensure extra safety, also prevent damage to wheels when contacting end rail stoppers.
- Wheels run on sealed ball bearings. Smoother rolling with less effort and maintenance.

RAY KISKACI / BEAM CLAMPS

	NL-BC 10	NL-BC 20	NL-BC 30	NL-BC 50	NL-BC 100		
Kapasitesi / Capacity	1000	2000	3000	5000	10000	kg	
Kapma genişliği / Flange width	75-230	75-230	80-320	90-310	90-320	mm	
Ölçüler / Dimensions	A (Max.)	246	246	320	310	320	mm
	B (Min./Max.)	186/ 350	186/ 350	232/ 455	242/ 445	268/ 480	mm
	C	66	74	102	110	118	mm
	D	4	6	8	10	12	mm
	E	215	215	255	255	275	mm
	F (Max./Min.)	133/ 90	133/ 90	195/ 143	193/ 145	185/ 133	mm
	G (Min.)	44	44	75	75	66	mm
	H	20	20	22	28	38	mm
I (Min./Max.)	14/ 21	14/ 21	30/ 34	30/ 34	34/ 35	mm	
Ağırlık / Weight	4	5	9.5	11.5	18	kg	

Art.No. 52000061	NL-BC 10
Art.No. 52000062	NL-BC 20
Art.No. 52000063	NL-BC 30
Art.No. 52000064	NL-BC 50
Art.No. 52000065	NL-BC 100

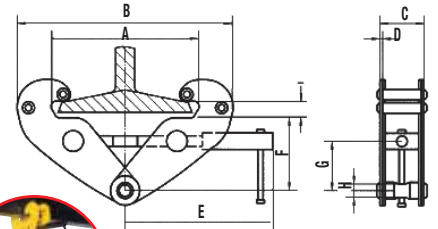

360° DÖNER CERASKAL / CHAIN HOIST

HSJ 360 1-3/2 HSJ 360 1-5/2 HSJ 360 2-3/2 HSJ 360 2-5/2 HSJ 360 3-3/2 HSJ 360 3-5/2

Kapasitesi / Capacity	1	1	2	2	3	3	ton
Kaldırma yüksekliği / Lift	3	5	3	5	3	5	m
El kuvveti / Hand force to lift load	24.49	24.49	33.56	33.56	41.73	41.73	kg
Ölçüler / Dimensions	14.93	14.93	21.64	21.64	26.51	26.51	mm
A	355.6	355.6	395	395	520	520	mm
B	22.2	22.2	30	30	38	38	mm
C	28.6	28.6	35	35	39.7	39.7	mm
D	14.3	14.3	20.6	20.6	25.4	25.4	mm
E	176	176	203	203	224	224	mm
F	155.6	155.6	182.5	182.5	220	220	mm
Ağırlık / Weight	13.9	16.9	21.6	21.6	30.6	30.6	kg



Art.No. 52000196	NL-HSJ 360 1-3/2
Art.No. 52000198	NL-HSJ 360 1-5/2
Art.No. 52000199	NL-HSJ 360 2-3/2
Art.No. 52000202	NL-HSJ 360 3-3/2
Art.No. 52000284	NL-HSJ 360 2-5/2
Art.No. 52000285	NL-HSJ 360 3-5/2



TEKNİK ÖZELLİKLER

- Her açıda ceraskal kullanımı
- Tehlikeli bölgelerde kullanımının serbest olması.
- Grade 100 (Seviye) yük zinciri – Wafios bağlantısı.
- Dövülmüş ve ısıtılmış görmüş yük kancaları.
- Çift tırnaklı fren sistemi
- Serbest fren balataları
- Dövülerek işlenmiş emniyet mandalı
- 1.5x WLL (Yük Çalışma Kapasitesi) için %100 yük testi.
- WLL'nin %400 MBL'si.
- Seri çevrim testi

KULLANIM ALANLARI

- Maden ocaklarında
- Petrol ve gas platformlarında
- Gemi inşaat sahasında
- Lojistik, orman alanlarında v.b.
- Köprü inşaatı sahasında, inşaat alanlarında v.b.
- Kaldırma, indirme, sökme ve bağlantıların sınırlı olduğu her yerde.

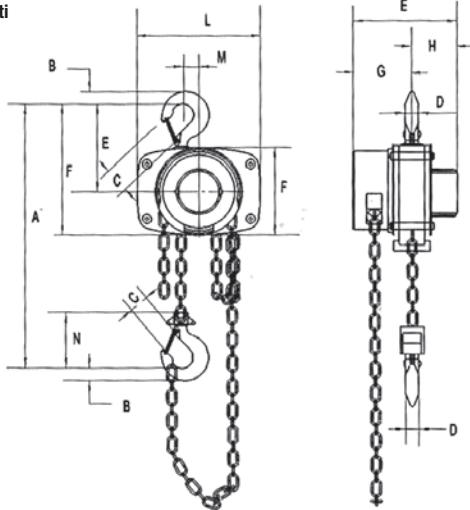

CERASKAL / CHAIN HOIST

NL-HSJ 1/4 NL-HSJ 1/2 NL-HSJ 1 NL-HSJ 2 NL-HSJ 3 NL-HSJ 5 NL-HSJ 10 NL-HSJ 20

Kaldırma kapasitesi / Capacity	1/4	1/2	1	2	3	5	10	20	ton
Standart yükseklik / Standard lift	3m/ 5m	3m/ 5m	3m/ 5m	3m/ 5m	5m	5m	5m	5m	m
Test yükü / Runnig test load	306	750	1500	3000	4500	6250	12500	25000	kg
Kapalı yükseklik / Headroom (drawn closeup) H min	230	271	400	420	620	704	720	1000	mm
Max yükte harcanan kuvvet / Effort required to life max. load	215	221	304	314	343	382	392	392	N
Zincir donam sayısı / No. of column of load chain	1	1	1	2	2	2	4	8	ad
Yük zinciri ölçüsü / Load chain dia.	4	6	6	6	8	10	10	10	mm
İlave her metre için ağırlık / Extra weight per meter of extra lift	0.4	1.7	1.7	2.5	3.7	5.3	9.7	19.4	kg
Ağırlık / Weight	3.5	9	11	15	24	39	72	160	kg



Art.No. 52000010	NL-HSJ 1/4-3
Art.No. 52000011	NL-HSJ 1/4-5
Art.No. 52000012	NL-HSJ 1/2-3
Art.No. 52000013	NL-HSJ 1/2-5
Art.No. 52000014	NL-HSJ 1-3
Art.No. 52000015	NL-HSJ 1-5
Art.No. 52000016	NL-HSJ 2-3
Art.No. 52000017	NL-HSJ 2-5
Art.No. 52000018	NL-HSJ 3-5
Art.No. 52000019	NL-HSJ 5-5
Art.No. 52000020	NL-HSJ 10-5
Art.No. 52000021	NL-HSJ 20-5

- Galvaniz zincir • Galvanized chain

ZİNCİRLİ ÇEKTİRME / LEVER HOIST

	NL-HSH-D 1/2	NL-HSH-D 1/4	NL-HSH-D 3/4	NL-HSH-D 1	NL-HSH-D 1.5	NL-HSH-D 3	NL-HSH-D 6	NL-HSH-D 9	
Kaldırma kapasitesi / Capacity	1/2	1/4	3/4	1	1.5	3	6	9	t
Çektirme mesafesi / Pulling distance	1	1	1.5	1.5	1.5	1.5	1.5	1.5	m
Test yükü / Running test load	375	375	1125	1.5	2250	4500	7500	11200	kg
Kapalı yükseklik / Headroom (drawn closeup) H min	230	230	325	340	380	480	620	700	mm
Max yükte harcanan kuvvet / Effort required to life max. load	250	250	140	187	220	320	340	360	N
Zincir donam sayısı / No. of column of load chain	1	1	1	1	1	1	2	3	ad
Yük zinciri ölçüsü / Load chain dia.	4	4	6	6	8	10	10	10	mm
İlave her metre için ağırlık / Extra weight per meter of extra lift	0.4	0.4	0.8	0.8	1.4	2.2	4.4	6.6	kg
Ağırlık / Weight	1.8	1.8	7	7.2	11	21	31	47	kg

• Galvaniz zincir • Galvanized chain



Art.No. 52000029

NL-HSH-D 1/2

Art.No. 52000022

NL-HSH-D 1/4

Art.No. 52000023

NL-HSH-D 3/4

Art.No. 52000024

NL-HSH-D 1

Art.No. 52000025

NL-HSH-D 1.5

Art.No. 52000026

NL-HSH-D 3

Art.No. 52000027

NL-HSH-D 6

Art.No. 52000028

NL-HSH-D 9

ZİNCİRLİ ŞARYO / GEARED TROLLEY

	NL-GT 0.5	NL-GT 1	NL-GT 2	NL-GT 3	NL-GT 5	NL-GT 10	NL-GT 20		
Kapasitesi / Capacity	0.5	1	2	3	5	10	20	t	
Çalışma yüksekliği / Running height	2.5	2.5	2.5	3	3	3	3	m	
Test yükü / Test load	7.35	14.71	29.42	44.13	61.29	122.58	245.7	kN	
Min. radyus açısı / Min. radius of curveve	0.8	0.9	1.0	1.2	1.3	2.0	3.5	m	
Harcanan güç / Chain pull to lift full load	25	50	90	96	140	240	240	N	
Ölçüler / Dimensions	A	272	336	350	358	373	52	98	mm
	B	194	236	268	322	362	424	555	mm
	C	176	208	247	295	342	396	498	mm
	H	95	111	134	157	185	190	233	mm
	F	1.5-3	1.5-3	1.5-3	2-3.5	2-3.5	2-3.5	2-3.5	mm
	S _≥	28	28	30	32	36	40	45	mm
	Putrel ölçüsü / I-beam commended	50-152	64-203	88-203	100-203	114-203	124-230	136-305	mm
Ağırlık / Weight	9	13	18	29	42	94	174	kg	

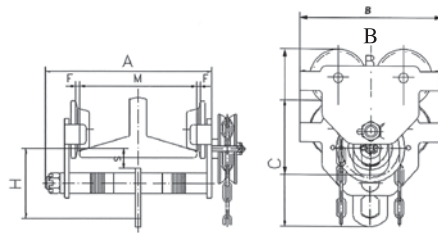

Art.No. 52000048

NL-GT 0.5

Art.No. 52000049

NL-GT 1

Art.No. 52000050

NL-GT 2

Art.No. 52000051

NL-GT 3

Art.No. 52000052

NL-GT 5

Art.No. 52000053

NL-GT 10

Art.No. 52000054

NL-GT 20



ŞARYO / MANUEL TROLLEY

	NL-PT 0.5	NL-PT 1	NL-PT 2	NL-PT 3	NL-PT 5		
Kapasitesi / Capacity	0.5	1	2	3	5	t	
Test yükü / Test load	7.35	14.71	29.42	44.13	61.29	kN	
Min. radyus açısı / Min. radius of curve	0.8	0.9	1.0	1.2	1.3	m	
Ölçüler / Dimensions	A	240	310	325	345	360	mm
	B	194	236	268	322	362	mm
	C	176	208	247	295	342	mm
	H	95	111	134	157	185	mm
	F	1.5-3	1.5-3	1.5-3	2-3.5	2-3.5	mm
	S _≥	28	28	30	32	36	mm
Putrel ölçüsü / I-beam commended	50-203	60-203	88-203	100-203	114-203	mm	
Ağırlık / Weight	5.5	9.5	14.5	24.5	37.4	kg	



Art.No. 52000055

NL-PT 0.5

Art.No. 52000056

NL-PT 1

Art.No. 52000057

NL-PT 2

Art.No. 52000058

NL-PT 3

Art.No. 52000059

NL-PT 5

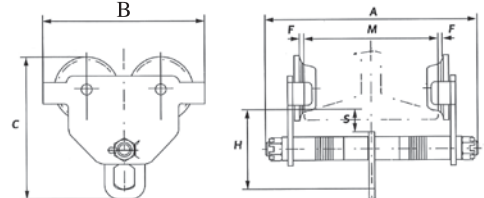

ELEKTRİKLİ HALATLI İRGAT / ELECTRIC WIRE WINCH

Kullanım Alanları:

Farklı inşaat alanları, fabrikalar, depolar, santraller, enerji tesisleri, barajlar, ziraat ve balıkçılık sektöründe, marketler, tesisat işlerinde güvenle kullanabileceğiniz yardımcıdır.

Özellikleri:

Isıl işlem görmüş aşınmayan dişliler sayesinde üstün performans, kompakt ve hafif, sessiz ve uzun ömürlü, sağlam gövde ve dişli sistemi, uzun ömürlü ağır hizmet rulmanlar, statik ve dinamik yükler için dizayn edilmiş fren sistemi, güç kaybında devreye giren otomatik fren sistemi, geniş sürtünme alanı, kullanıma hazır endüksiyon motor.



Kod No Code No	Model	Kapasite Capacity (kg)	Güç Kaynağı (Voltaj/ Voltage) Power Supply (Voltaj/ Voltage) (V)	Faz Phase	Çelik Halat Çapı Wire Rope Dia. (mm)	Çelik Halat Uzunluğu Wire Rope Length (m)	Hız Speed (m / dk)	Motor Gücü Motor Power (kw)	Net Ağırlık Net Weight (kg)	Brüt Ağırlık Gross Weight (kg)
							50 Hz			
71600221	NX-221H	250	220	1	7	30	33	1.5	41	45
71600208	NX-208	350	220	1	7	30	15	1.5	42	43
71600223	NX-223H	350	220	1	7	30	38	2	66	71
71600210	NX-210	500	220	1	8	45	21	2	70	76
71601212	NX-212	1000	380	3	10	45	12	3	133	145
71602000	NX-2K	2000	380	3	12	45	12	5	183	171
71602213	NX-213	2000	380	3	12	80	12	5	364	392
71603000	NX-3K	3000	380	3	14	45	12	7.5	205	193
71603214	NX-214	3000	380	3	14	80	12	7.5	375	405
71605215	NX-215	5000	380	3	16	80	12	10	395	426

Ölçüler/ Dimensions

Kapasite Capacity (kg)	L (mm)	W (mm)	H (mm)
250	585	201	233
350	585	201	233
350	675	220	283
500	710	310	285
1000	1120	385	340
2000	1190	400	365
2000	1290	590	520
3000	1240	400	365
3000	1350	590	520
5000	1450	590	520

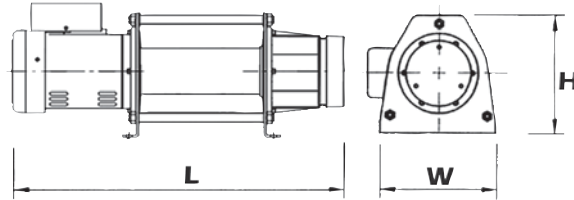

Usage:

Fit for various construction workplaces, civil engineering, general factories, plumbing, coating, scaffolding, warehousing, buildings, domestics, farming and fishing industries, stroes and even more.

Features:

Driving gear the heat treated gear with bearings features durable performance and anti-wear. Planetary and anti-wear gears. Compact and load sharing inimiz size, weight and cost. Full depth spur gear planetary reductions ensure quiet and long life. Gear box provides strength, durability and non-worry of breakage of structure. Ball bearings High efficient and heavy duty berings provide long life. Brake Designed for both static and dynamic loading. Brake will automatically apply in the event of power loss. Large friction surface area.



ELEKTRİKLİ HALATLI İRGAT / ELECTRIC WIRE WINCH

Kullanım Alanları:

Farklı inşaat alanları, fabrikalar, depolar, santraller, enerji tesisleri, barajlar, ziraat ve balıkçılık sektöründe, marketler, tesisat işlerinde güvenle kullanabileceğiniz yardımcınız.

Özellikleri:

Kaldırma ve çekme işlemlerinde özellikle ağır hizmet uygulamalarında yüksek çalıştırma torkuna sahip bir üründür. Isıl işlem görmüş aşınmayan dişliler sayesinde üstün performans, kompakt ve hafif, sessiz ve uzun ömürlü, sağlam gövde ve dişli sistemi, uzun ömürlü ağır hizmet rulmanlar.



Kod No Code No	Model	Kapasite Capacity (kg)	Güç Kaynağı (Voltaj/ Voltage) Power Supply (Voltaj/ Voltage) (V)	Faz Phase	Çelik Halat Çapı Wire Rope Dia. (mm)	Çelik Halat Uzunluğu Wire Rope Length (m)	Hız Speed (m / dk)	Motor Gücü Motor Power (kw)	Net Ağırlık Net Weight (kg)
							50 Hz		
71600001	AMW-1000	1000	380	3	11	60	13-19	3	160
71600002	AMW-1600	1600	380	3	13	100	13-19	4	185
71600003	AMW-3200	3200	380	3	18	45	8-14	7.5	440

ÇOK AMAÇLI AKÜLÜ İRGAT / MULTIPURPOSE ELECTRIC PULLER

NL-A100

Yuvarlama kapasitesi / Rolling capacity	2722/6000	kg/ lbs
Marine kapasitesi / Marine capacity	2268/5000	kg/ lbs
Çekme kapasitesi / Pulling capacity	907/2000	kg/ lbs
Hız(yüklü) / Line speed (with load)	1.8	m/min
Halat (çap / uzunluk) Wire rope (Dia x L)	5.1mm x 9m	mm/m
Güç kablosu / Power cord	4.5mm / 3m	mm/m
Motor / Motor	0.4	hp
Çalışma voltajı / Voltage	12	V/DC
Ölçüler / Dimensions	240x254x190	mm
Ağırlık / Weight	13	kg

*Montaj plakası ve krank mili dahildir. / Mounting plate and hand crank included.

Art.No. 59000093

NL-A100



ÇOK AMAÇLI AKÜLÜ İRGAT / MULTIPURPOSE ELECTRIC PULLER

NL-A101

Yuvarlama kapasitesi / Rolling capacity	4082/9000	kg/ lbs
Marine kapasitesi / Marine capacity	3175/7000	kg/ lbs
Çekme kapasitesi / Pulling capacity	1365/3000	kg/ lbs
Hız(yüklü) / Line speed (with load)	1.8	m/min
Halat (çap / uzunluk) Wire rope (Dia x L)	5.6mm x 9m	mm/m
Güç kablosu / Power cord	4.5mm / 3m	mm/m
Motor / Motor	0.6	hp
Çalışma voltajı / Voltage	12	V/DC
Ölçüler / Dimensions	260x305x193	mm
Ağırlık / Weight	15.7	kg

*Montaj plakası ve krank mili dahildir. / Mounting plate and hand crank included.

Art.No. 59000094

NL-A101



AKÜLÜ İRGAT / ELECTRIC PULLER

NL-A094

Art.No. 59000090

NL-A094

Kapasite / Capacity	909kg / 2000 lbs
Motor / Motor	12V 1.1 HP
Halat (çap/uzunluk) / Cable (Dia. x L)	4.8 mm x 7.6 m
Makara(çap/uzunluk) / Drum size (Dia. x L)	32 mm x 73 mm
Montaj civatası / Mounting bolt pattern	80mm 2-M8

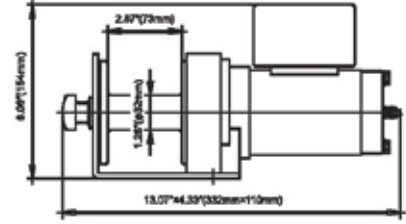

Makaralı halat çekme kapasitesi Line pull and rope capacity inlayer			Hız ve voltaj akımı Speed and Volts		
Kat Layer	Çekme gücü Ratel line pull (kg/lbs)	Makaralı halat Total rope on drum ft(m)	Çekme kolu Line pull Kg / Lbs	Hız / Line speed Ft / min (m/min)	Akım Current A
1	909 (2000)	5.5 (1.68)	0	14 (4.26)	8
2	721 (1586)	12.43 (3.79)	454 (1000)	10 (3.05)	35
3	597 (1314)	20.8 (6.34)	682 (1500)	8 (2.44)	58
4	509 (1121)	25 (7.6)	909 (2000)	4 (1.22)	85

AKÜLÜ İRGAT / ELECTRIC PULLER

NL-A096

Art.No. 59000091

NL-A096

Kapasite / Capacity	2045g / 4500 lbs
Motor / Motor	12V 2.0 HP
Halat (çap/uzunluk) / Cable (Dia. x L)	6 mm x 12 m
Makara(çap/uzunluk) / Drum size (Dia. x L)	55 mm x 75 mm
Montaj civatası / Mounting bolt pattern	123x76mm 4-M8

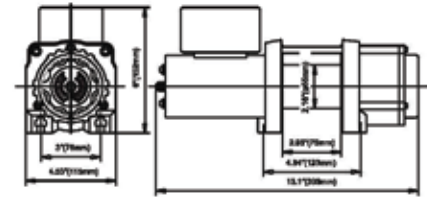

Makaralı halat çekme kapasitesi Line pull and rope capacity inlayer			Hız ve voltaj akımı Speed and Volts		
Kat Layer	Çekme gücü Ratel line pull (kg/lbs)	Makaralı halat Total rope on drum ft(m)	Çekme kolu Line pull Kg / Lbs	Hız / Line speed Ft / min (m/min)	Akım Current A
1	2045 (4500)	7.87 (2.4)	0	16 (4.88)	17
2	1726 (3798)	17.26 (5.26)	227 (500)	12.5(3.81)	50
3	1493 (3285)	28.2 (8.59)	909 (2000)	9.6(2.92)	130
4	1316 (2895)	39 (12)	2045 (4500)	3 (0.914)	245

AKÜLÜ İRGAT / ELECTRIC PULLER

NL-A097

Art.No. 59000092

NL-A097

Kapasite / Capacity	4545g / 10000 lbs
Motor / Motor	12V 6 HP
Halat (çap/uzunluk) / Cable (Dia. x L)	6 mm x 12 m
Makara(çap/uzunluk) / Drum size (Dia. x L)	9.2 mm x 28 m
Montaj civatası / Mounting bolt pattern	254x114mm 4-M10

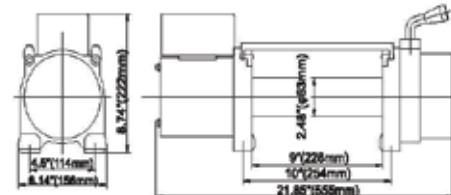

Makaralı halat çekme kapasitesi Line pull and rope capacity inlayer			Hız ve voltaj akımı Speed and Volts		
Kat Layer	Çekme gücü Ratel line pull (kg/lbs)	Makaralı halat Total rope on drum ft(m)	Çekme kolu Line pull Kg / Lbs	Hız / Line speed Ft / min (m/min)	Akım Current A
1	4545 (10000)	18 (5.5)	0	19.45 (5.93)	50
2	3622 (7969)	41 (12.5)	1363 (3000)	17.45 (5.32)	150
3	3010 (6623)	68.5 (20.9)	2727 (6000)	15.45 (4.71)	200
4	2576 (5667)	92 (28)	3636 (8000)	12.46 (3.8)	270
5			4545 (10000)	10.5 (3.2)	320

ELEKTRİKLİ MİNİ VİNÇ / MINI WIRE ROPE HOIST

NL-EW 100-200

Kaldırma kapasitesi / Capacity (Tek-Çift hat) / (Single-Double Line)	100/ 200	kg
Kaldırma yüksekliği / Lifting height (Tek-Çift hat) / (Single-Double Line)	25/ 11,5	m
Koruma sınıfı / Protection class	IP54	
Kaldırma hızı / Lifting speed (Tek-Çift hat) / (Single-Double Line)/	10/ 5	m/ dk
Halat uzunluğu / Wire rope length	25	m
Halat çapı / Wire rope diameter	3	mm
Motor gücü / Motor power	500	W
Voltaj / Power source (Tek-Çift hat) / (Single-Double Line)	230/ 50	V/Hz

Art.No. 52500042

NL-EW 100-200



ELEKTRİKLİ MİNİ VİNÇ / MINI WIRE ROPE HOIST

NL-EW 125/250

NL-EW 250/500

Kaldırma kapasitesi / Capacity (Tek-Çift hat) / (Single-Double Line)	125/ 250	250/ 500	kg
Kaldırma yüksekliği / Lifting height (Tek-Çift hat) / (Single-Double Line)	11/ 5.5	12/ 6	m
Koruma sınıfı / Protection class	IP54	IP54	
Kaldırma hızı / Lifting speed (Tek-Çift hat) / (Single-Double Line)	10/ 5	10/ 5	m/ dk
Halat uzunluğu / Wire rope length	12	12	m
Halat çapı / Wire rope diameter	3	4	mm
Motor gücü / Motor power	580	930	W
Voltaj / Power source (Tek-Çift hat) / (Single-Double Line)	230/ 50	230/ 50	V/Hz

Art.No. 52500040

NL-EW 125/250

Art.No. 52500041

NL-EW 250/500



- Limit şalteri • Limit switch
- Acil stop butonu • Emergency stop button

ELEKTRİKLİ MİNİ VİNÇ / MINI WIRE ROPE HOIST

NL-EW 200-400

NL-EW 500-1000

Kaldırma kapasitesi / Capacity (Tek-Çift hat) / (Single-Double Line)	200 - 400	500 - 1000	kg
Kaldırma yüksekliği / Lifting height (Tek-Çift hat) / (Single-Double Line)	25/11.5	12/6	m
Koruma sınıfı / Protection class	IP 54	IP 54	
Kaldırma hızı / Lifting speed (Tek-Çift hat) / (Single-Double Line)/	10/ 5	10/ 5	m/ dk
Halat uzunluğu / Wire rope length	12	12	m
Halat çapı / Wire rope diameter	3.6	6	mm
Motor gücü / Motor power	1050	1650	W
Voltaj / Power source (Tek-Çift hat) / (Single-Double Line)	230/ 50	230/ 50	V/Hz

Art.No. 52500043

NL-EW 200-400

Art.No. 52500044

NL-EW 500-1000



MİNİ VİNÇ AYAĞI / WINCH SUSPENSION SYSTEM

NL-WT 250-1100

NL-WT 300-750

Kapasite/ Rated lifting	250	600	kg
Maks. uzatma boyu / Max extension length	1200	750	mm
Brüt ağırlık / Gross weight	30	38	kg
Net ağırlık / Net weight	28	36	kg

Art.No. 52500045

NL-WT 300-750

Art.No. 52500046

NL-WT 250-1100

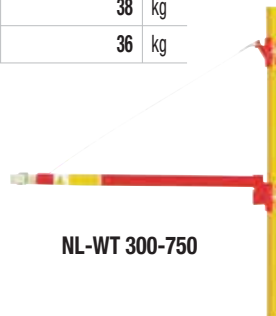

NL-WT 300-750

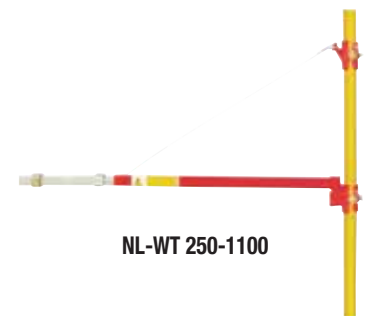

NL-WT 250-1100

HALATLI ÇEKTİRME Alüminyum Gövdeli / ALUMINIUM HOUSING PULLING HOIST

	NL-HX 800A	NL-HX 1600A	NL-HX 3200A		
Kapasitesi / Capacity	800	1600	3200	kg	
Halat çapı / Rope diameter	8.3	11	16	mm	
Ölçülen ileri el hareket gücü / Rated forward handpower	343	441	441	N	
Ölçülen ileri hareket / Rated forward travel	≥52	≥55	≥28	mm	
Test yükü / Proof test load	1200	2400	4000	kg	
Çelik halat emniyet faktörü ve yük kapasitesi/ Wire rope safety factor and load capacity/	5	5	5		
Emniyet faktörü/ Statik yük kapasitesi/ Safety factor and static load capacity	5	5	5		
Ölçüler / Dimensions	A	426	545	660	mm
	B	235	280	325	mm
	C	168	190	230	mm
	L1		800	800	mm
	L2	800	1200	1200	mm
Ağırlık / Weight	6	11	22	kg	

- Hafif, küçük ve sağlam alüminyum gövde
- Ön koldaki pim mekanizması ile sağlanan aşırı yük koruma sistemi. Taşıma kolunda veya operasyon levyesinde yedek makas pimleri
- Çelik halatın kolayca monte edilmesini sağlayan mekanizma
- Birim harekette uzun halat hareketi
- Test edilmiş %150 aşırı yük testlidir
- Üstte rahat temizliği kolaylaştıran geniş açıklık
- Makine Emniyet Yönetmeliği 2006/42 EC'ye uygun üretilmiştir.
- Özel siparişlerde çelik halat seti ile teslim
- Standart çelik halat uzunluğu 20 ve 30 metredir.

- Light weight, compact, high strength aluminium housing
- Overload protection is by a sharing pin in the forward lever. Spare shear pins are conveniently located in the carrying handle or operating lever
- Easy, smooth installation of the wire rope
- Long rope advance per each lever stroke
- 150% overload factory tested
- Large opening in the top of the unit for cleaning
- Manufactured according to machinery directive 2006/42/EC
- Can be supplied with wire rope set to special order
- The standard wire rope lengths are 20 and 30 metres.

Halat uzunluğu/ Rope length:

20m	30m	
Art.No. 52000090	Art.No. 52000091	NL-HX 800 A
Art.No. 52000092	Art.No. 52000093	NL-HX 1600 A
Art.No. 52000094	Art.No. 52000095	NL-HX 3200 A

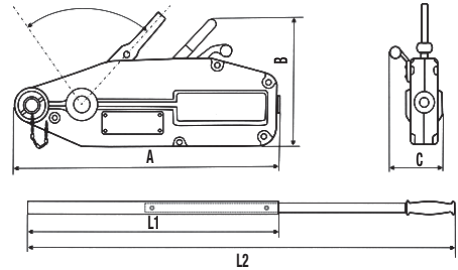

HALATLI ÇEKTİRME Çelik Gövdeli / IRON HOUSING PULLING HOIST

	NL-HX 800S	NL-HX 1600S	NL-HX 3200S		
Kapasitesi / Capacity	800	1600	3200	kg	
Halat çapı / Rope diameter	8.3	11	16	mm	
Ölçülen ileri el hareket gücü / Rated forward handpower	343	441	441	N	
Ölçülen ileri hareket / Rated forward travel	≥52	≥55	≥28	mm	
Test yükü / Proof test load	1200	2400	4000	kg	
Çelik halat emniyet faktörü ve yük kapasitesi/ Wire rope safety factor and load capacity/	5	5	5		
Emniyet faktörü/ Statik yük kapasitesi/ Safety factor and static load capacity	5	5	5		
Ölçüler / Dimensions	A	440	550	690	mm
	B	265	300	350	mm
	C	63	77	91	mm
	L1		800	800	mm
	L2	800	1200	1200	mm
Ağırlık / Weight	18	30	56	kg	

Halat uzunluğu/ Rope length:

20m	30m	
Art.No. 52000096	Art.No. 52000097	NL-HX 800 S
Art.No. 52000098	Art.No. 52000099	NL-HX 1600 S
Art.No. 52000100	Art.No. 52000101	NL-HX 3200 S

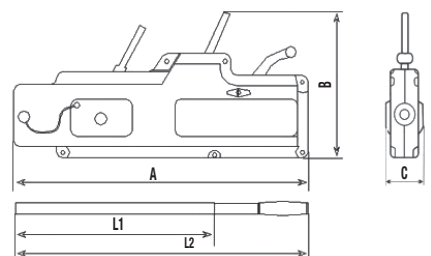

HALATLI ÇEKTİRME Alüminyum Gövdeli / ALUMINUM HOUSING PULLING HOIST

NL-HX 5400A

Halat uzunluğu/ Rope length:

20m 30m

Art.No. 52000102

Art.No. 52001002

NL-HX 5400 A

Kapasitesi / Capacity		5400	kg
Halat çapı / Rope diameter		20	mm
Ölçülen ileri el hareket gücü		745	N
Ölçülen ileri hareket /Rated forward travel		≥30	mm
Test yükü / Proof test load		8000	kg
Çelik halat emniyet faktörü ve yük kapasitesi/ Wire rope safety factor and load capacity		5	mm
Emniyet faktörü/ Statik yük kapasitesi/ Safety factor and static load capacity		5	mm
Ölçüler / Dimensions	A	932	mm
	B	420	mm
	C	300	mm
	L1	880	mm
	L2	1360	mm

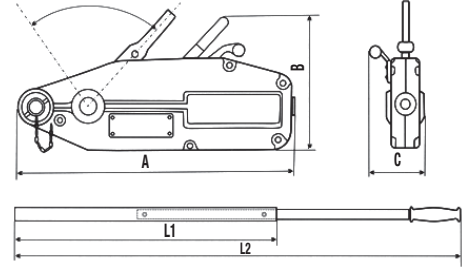
**HALATLI ÇEKTİRME / HAND POWER PULLER**

NL-HP 147 D

Kapasite/ Capacity	4000	kg
Halat ölçüleri / Cable	6 x 3000	mm
Kanca sayısı / Hook	3	
Et kalınlığı (kol) / Thickness handle	5	mm
Et kalınlığı (gövde) / Thickness body	6	mm
Ağırlık / Weight	7.3	kg

Art.No. 52000116

NL-HP 147 D**POLYESTER BANTLI ÇEKTİRME / WEB-STRAP PULLER**

NL-WS 10

NL-WS 15

Kapasite / Capacity	1000	1500	kg
Bant ölçüsü / Strap dimension	2 x 33	2.2 x 40	mm
Kol uzunluğu / Lever length	400	460	mm
Maks. uzunluk / Max. length	1280	1320	mm
Min. uzunluk / Min. length	420	450	mm
Ağırlık / Weight	3.2	4.5	kg

Art.No. 52000118

NL-WS 10

Art.No. 52000119

NL-WS 15**ELEKTRİKLİ VİNÇ-IRGAT / ELECTRIC ROPE PULLER**

EWP 250-15

EWP 500-15

EWP 500-30

Çekme gücü / Pulling force in the upper layer	250	500	500	kg
Kaldırma hızı / Lifting speed	15	15	30	m/min
Çelik halat / Wire rope	5	6	6	mm
Motor gücü / Motor performance	0.55	1.1	2.2	kw
Standart halat boyu / Standart rope length	60	60	60	m
Halatsız ağırlık / Weight without rope	55	90	96	kg
Voltaj / Voltage		380		V

Art.No. 52500067

NL-EWP 250-15

Art.No. 52500069

NL-EWP 500-15

Art.No. 52500070

NL-EWP 500-30

Her vinç aşırı yükte test edilmiştir. DIN15020'ye, VBG8 (vinç, kaldırma, çekme ekipmanları) güvenlik tüzüğüne ve EC makine direktiflerine uyumludur. Az yer kaplayan ölçüleri iç fren motoruna uygundur. Standart: Euro-Voltaj 230/400V, 50Hz 3 faz, Koruma sınıfı IP 54,izolasyon sınıfı F. Tetikleyici dişli güç aktarım sistemi sayesinde düzgün hareket sağlar. Yağlanarak kolay işler hale getirilir. Motorun içine dahil edilmiş olan fren diski elektrik kesildiğinde bile yükü güvenli bir şekilde tutar. Düz halat tambur standardındadır. Halat sonu tambura sabitlendiği için zarar görmeden defalarca sarılıp açılabilir. Direk kontrol standarttır.

Every winch is factory tested with overload. In accordance with DIN15020, safety regulation VBG8 (winch, lift and pull equipment) and the EC machinery directives. Compact dimensions due to internal brake motor. Standard: Euro- voltage 230/400V, 50Hz. 3-phase, protected to IP 54, Insulation class F. Spur gear transmission with helical first gear ensures smooth motion. Lubricated by grease and can, therefore, be used in any position. Spring pressure disc brake incorporated in the motor holds the load secure even in the event of power failure. Plain rope drum standard. The rope is secured to the drum in a recess so that the rope can be wound onto the drum in several layers without damage. Direct control as standard.

EMNİYETLİ MANUEL İRGAT / BRAKE WINCH

	NL-BHW 800	NL-BHW 1200	NL-BHW 1800	NL-BHW 2600
Kapasite / Capacity	360	550	800	1180
Gerekli el kuvveti / Required hand force	20	14	22	10
Dışli oranı / Gear ratio	4.1 : 1	4.1 : 1	5 : 1	10 : 1
Irgat göbek çapı / Hub diameter	40	50	70	80
Kol uzunluğu / Handle length	160	210	320	320
Halat çapı / Cable diameter	4	4.8	6.4	8
Kablo muhafaza kapasitesi / Cable storage cap.	36	23	24	18
Birim ağırlığı / Unit weight	3	3.3	8	10.3

Art.No. 52000190	NL-BHW 800
Art.No. 52000127	NL-BHW 1200
Art.No. 52000128	NL-BHW 1800
Art.No. 52000191	NL-BHW 2600
Art.No. 52000192	NL-BHW 800 PLUS
Art.No. 52000193	NL-BHW 1200 PLUS
Art.No. 52000194	NL-BHW 1800 PLUS
Art.No. 52000195	NL-BHW 2600 PLUS

- Kompakt, hafif ve sağlam ürün yapısına sahiptir.
- Dişliler ve fren mekanizması, toz, kir ve yağmur atıklarından korumayı sağlamak üzere kapalı sistem tasarlanmıştır.
- Operatör ürünü kullanırken çok az enerji sarf eder.
- Üniversal montaj plakasına sahiptir.
- Renkli fırınlanmış emaye kaplama sayesinde korozyon dayanımını artırılmıştır.

- Positive load, actuated brake can hold the load in any position
- Compact, light-weight and rugged construction
- Gears and brake are fully covered to prevent dust, dirt and rain contamination
- Very low operator effort is required for easy operation
- Universal mounting base
- Baked yellow enamel paint finish for corrosion protection



NL- BHW 2600

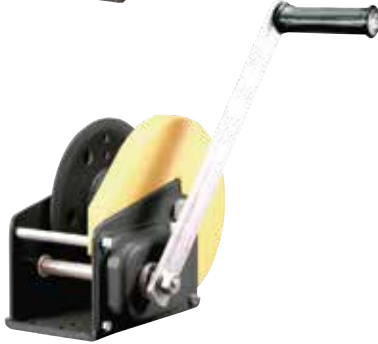
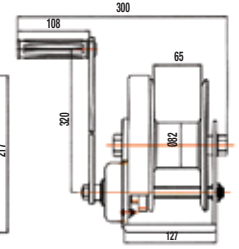
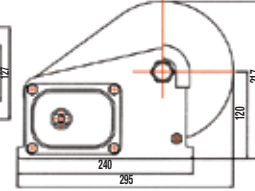
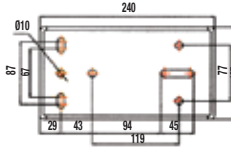

NL- BHW 1800

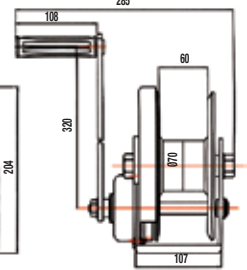
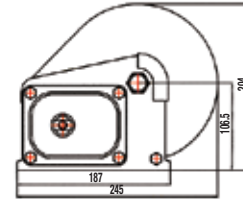
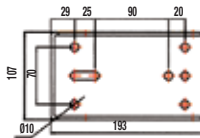

NL- BHW 1200

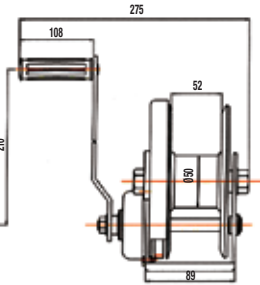
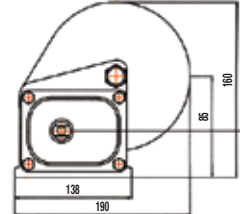
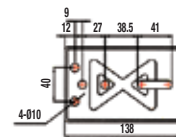

NL- BHW 800

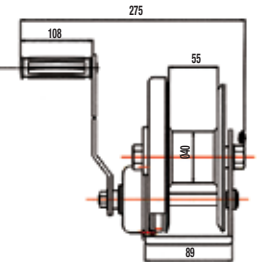
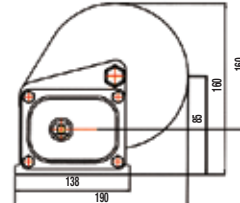
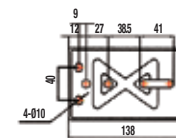

POLYESTER HALATLI IRGAT / BRAKE WINCH WITH WEBBING

	BHW 800W	BHW 1200W	BHW 1800W	BHW 2600W	
Kapasite / Capacity	360	550	800	1180	kg
Gerekli el kuvveti / Required hand force	20	14	22	10	kg
Dışli oranı / Gear ratio	4.1 : 1	4.1 : 1	5 : 1	10 : 1	
Irgat göbek çapı / Hub diameter	40	50	70	80	mm
Kol uzunluğu / Handle length	160	210	320	320	mm
Birim ağırlığı / Unit weight	3	3.3	8	10.3	kg
Polyester bant uzunluğu / Length of polyester	6	6	6	6	m

Art.No. 52000208

NL-BHW 800W

Art.No. 52000214

NL-BHW 1800W

Art.No. 52000209

NL-BHW 1200W

Art.No. 52000219

NL-BHW 2600W



KABLO ÇEKİTİRME APARATI (mini) / WIRE GRIP (mini)

NL-WG 05G

Kapasite / Capacity	500	kg
Min. kablo çapı / Min. cable dia.	1	mm
Max. kablo çapı / Max. cable dia.	10	mm
Ağırlık / Weight	0.4	kg

- Bakır kaplı, kılavuz kabloları, dikenli tel ve kılavuz telleri çekmede kullanılır.
- Used for copper cable, covered conductor, steel rod, messenger wire and barbed wire.

Art.No. 52000122

NL-WG 05G



KABLO ÇEKİTİRME APARATI / WIRE GRIP

NL-WG SDL 10C

Kapasite / Capacity	500	kg
Min. kablo çapı / Min. cable dia.	2.6	mm
Max. kablo çapı / Max. cable dia.	15	mm
Ağırlık / Weight	0.75	kg

- Bakır kaplı, kılavuz kabloları, dikenli tel ve kılavuz telleri çekmede kullanılır.
- Used for copper cable, covered conductor, steel rod, messenger wire and barbed wire.

Art.No. 52000124

NL-WG SDL 10C



KABLO ÇEKİTİRME APARATI / WIRE GRIP

NL-WG 30MCL

Kapasite / Capacity	3000	kg
Min. kablo çapı / Min. cable dia.	8	mm
Max. kablo çapı / Max. cable dia.	25	mm
Ağırlık / Weight	2.2	kg

- Bakır kaplı, kılavuz kabloları ve kılavuz telleri çekmede kullanılır.
- Used for copper cable, covered conductor, messenger wire and barbed wire.

Art.No. 52000125

NL-WG 30MCL



KABLO ÇEKİTİRME APARATI / WIRE GRIP

NL-WG 1656-20

Kapasite / Capacity	2000	kg
Min. kablo çapı / Min. cable dia.	5	mm
Max. kablo çapı / Max. cable dia.	10	mm
Çene uzunluğu / Jaw length	105	mm
Ağırlık / Weight	1.36	kg

- Alüminyum ve bakır kablolar için uygundur.
- Tutma yüzeyinin büyüklüğü kabloya az zarar verilmesini önler.
- Used for bare A.C.S.R. aluminium and stranded-copper cable.
- Maximum contact; less damage for conductors.

Art.No. 52000126

NL-WG 1656-20





NET MAK
METAL MAKİNA SANAYİ VE TİCARET LTD. ŞTİ.

200 TON'a kadar olan YÜKLERİNİZİ TAŞIR!

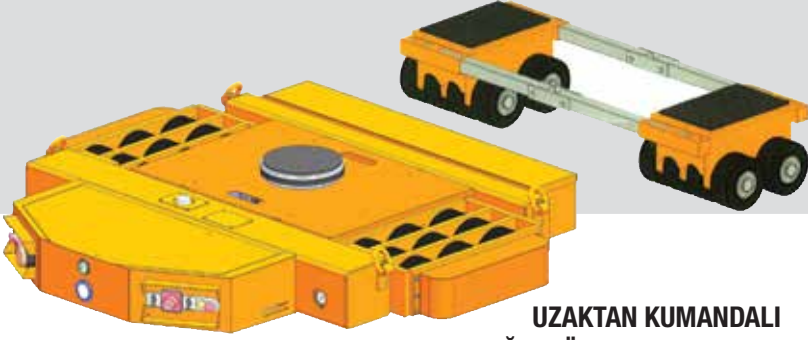

**UZAKTAN KUMANDALI
AĞIR YÜK TAŞIMA ARABALARI**



REMOTE
KONTROL

UZAKTAN
KUMANDALI



HİDROLİK KRİKOLAR
HYDRAULIC JACKS

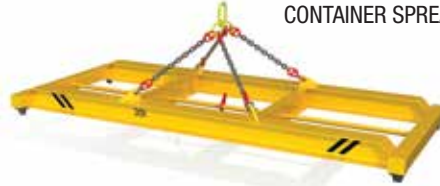

**KONTEYNER
TRAVERS**
CONTAINER SPREADER



ÖZEL TRAVERSLER
SPECIAL BEAMS



YÜK ARABALARI
TROLLEYS



H TİPİ TRAVERSLER
H TYPE BEAMS



**MOTORLU
TRAVERSLER**
ROTATING BEAMS



**MOTORLU RULO
TAŞIMA ARABASI**
MOTORIZED
TROLLEYS FOR REELS



**ALÜMİNYUM
TAŞINABİLİR
TRAVERSLER**
ALUMINIUM PORTABLE
GANTRIES



**MİKNATISLI
TRAVERSLER**
MAGNET BEAMS



**ÇİFT KOLLU
C KANCALAR**
DOUBLE
C TYPE HOOKS

**ELEKTRONİK
KANCALI VİNÇ**
ELECTRONIC
HOOK BLOCK
WEIGHT CRANE



C KANCALAR
C TYPE HOOKS



■ **Silindirler**
Cylinders

■ **El Pompaları**
Hand Pumps

■ **Elektrikli Pompalar**
Electric Pumps

■ **Hidrolik Ayırıcılar**
Hydraulic Spreaders

■ **Tork Anahtarları**
Torque Wrench

HİDROLİK KRIKO ve EKİPMANLARI

HIGHT PRESSURE HYDRAULIC TOOLS AND EQUIPMENTS

PRATİK SİLİNDİR SEÇİM TABLOSU CYLINDER QUICK SELECTION CHART

Kapasite Capacity (t)	Silindir Tipi Cylinder Type	Strok Stroke (mm)	Kapalı Yükseklik Collapsed Height (mm)	MODEL	Sayfa no
2.5	Çekiş Silindiri / Pully Cylinder	127	265	ESP-25	192
	Tek Tesirli-Genel / Single Acting-General	16	41	ES-50	173
5	Tek Tesirli-Genel / Single Acting-General	25	110	ES-51	173
	Tek Tesirli-Genel / Single Acting-General	75	165	ES-53	173
	Tek Tesirli-Genel / Single Acting-General	127	216	ES-55	173
	Tek Tesirli-Genel / Single Acting-General	177	44	ES-57	173
	Tek Tesirli-Genel / Single Acting-General	232	324	ES-59	173
	Tesirli-Düşük Yük. / Single Acting-Low Height	6	33	ESL-50	174
	Çekiş Silindiri / Pully Cylinder	140	302	ESP-46	192
	Tek Tesirli-Genel / Single Acting-General	26	90	ES-101	173
	Tek Tesirli-Genel / Single Acting-General	54	121	ES-102	173
	Tek Tesirli-Genel / Single Acting-General	105	171	ES-104	173
10	Tek Tesirli-Genel / Single Acting-General	156	248	ES-106	173
	Tek Tesirli-Genel / Single Acting-General	203	298	ES-108	173
	Tek Tesirli-Genel / Single Acting-General	257	349	ES-1010	173
	Tek Tesirli-Genel / Single Acting-General	304	400	ES-1012	173
	Tek Tesirli-Genel / Single Acting-General	356	451	ES-1014	173
	Tek Tesirli-Düşük Yük. / Single Acting-Low Height	10	43	ESL-100	174
	Tek Tesirli-Düşük Yük. / Single Acting-Low Height	38	88	ESL-101	176
	Çift Tesirli / Double Acting	254	409	ED-1010	182
	Çift Tesirli / Double Acting	305	457	ED-1012	182
	Çekiş Silindiri / Pully Cylinder	151	587	ESP-106C	192
13	Çekiş Silindiri / Pully Cylinder	151	542	ESP-106L	192
	Çekiş Silindiri / Pully Cylinder	151	289	ESP-106	192
	Tek Tesirli - Ortası Delik / Single Acting - Hollow	8	55	ESH-120	178
15	Tek Tesirli - Ortası Delik / Single Acting - Hollow	42	120	ESH-121	178
	Tek Tesirli - Ortası Delik / Single Acting - Hollow	76	184	ESH-123	178
	Tek Tesirli-Genel / Single Acting-General	25	124	ES-151	192
20	Tek Tesirli-Genel / Single Acting-General	51	149	ES-152	192
	Tek Tesirli-Genel / Single Acting-General	101	200	ES-154	192
	Tek Tesirli-Genel / Single Acting-General	152	272	ES-156	192
	Tek Tesirli-Genel / Single Acting-General	203	322	ES-158	192
	Tek Tesirli-Genel / Single Acting-General	254	373	ES-1510	192
	Tek Tesirli-Genel / Single Acting-General	305	424	ES-1512	192
	Tek Tesirli-Genel / Single Acting-General	356	475	ES-1514	192
	Tek Tesirli-Düşük Yük. / Single Acting-Low Height	11	52	ESL-200	174
25	Tek Tesirli-Düşük Yük. / Single Acting-Low Height	45	99	ESL-201	176
	Tek Tesirli-Alüminyum / Single Acting-Aluminum	54.10	162	ESA-202	177
	Tek Tesirli-Alüminyum / Single Acting-Aluminum	104.90	213	ESA-204	177
	Tek Tesirli-Alüminyum / Single Acting-Aluminum	155.95	263	ESA-206	177
	Tek Tesirli - Ortası Delik / Single Acting - Hollow	49	162	ESH-202	178
	Tek Tesirli - Ortası Delik / Single Acting - Hollow	155	306	ESH-206	178
	Tek Tesirli-Genel / Single Acting-General	26	140	ES-251	192
	Tek Tesirli-Genel / Single Acting-General	50	165	ES-252	192
30	Tek Tesirli-Genel / Single Acting-General	102	216	ES-254	192
	Tek Tesirli-Genel / Single Acting-General	158	273	ES-256	192
	Tek Tesirli-Genel / Single Acting-General	210	324	ES-258	192
	Tek Tesirli-Genel / Single Acting-General	261	375	ES-2510	192
	Tek Tesirli-Genel / Single Acting-General	311	425	ES-2512	192
	Tek Tesirli-Genel / Single Acting-General	362	476	ES-2514	192
	Tek Tesirli-Genel / Single Acting-General	209	387	ES-308	192
	Tek Tesirli-Düşük Yük. / Single Acting-Low Height	13	59	ESL-300	174
50	Tek Tesirli-Düşük Yük. / Single Acting-Low Height	62	118	ESL-302	176
	Tek Tesirli-Alüminyum / Single Acting-Aluminum	54.10	187	ESA-302	177
	Tek Tesirli-Alüminyum / Single Acting-Aluminum	104.90	238	ESA-304	177
	Tek Tesirli-Alüminyum / Single Acting-Aluminum	155.95	289	ESA-306	177
	Tek Tesirli - Ortası Delik / Single Acting - Hollow	64	179	ESH-302	178
	Tek Tesirli - Ortası Delik / Single Acting - Hollow	155	330	ESH-306	178
	Çift Tesirli - Ortası Delik / Double Acting - Hollow	178	330	EDH-307	180
	Çift Tesirli - Ortası Delik / Double Acting - Hollow	258	431	EDH-3010	180
	Çift Tesirli / Double Acting	209	387	ED-308	182

Kapasite Capacity (t)	Silindir Tipi Cylinder Type	Strok Stroke (mm)	Kapalı Yükseklik Collapsed Height (mm)	MODEL	Sayfa no
30	Çift Tesirli / Double Acting	368	546	ED-3014	182
	Çekiş Silindiri / Pully Cylinder	155	1085	ESP-306	192
	Tek Tesirli-Düşük Yük. / Single Acting-Low Height	16	67	ESL-500	174
	Tek Tesirli-Düşük Yük. / Single Acting-Low Height	60	122	ESL-502	174
	Tek Tesirli-Genel / Single Acting-General	51	176	ES-502	192
	Tek Tesirli-Genel / Single Acting-General	102	227	ES-504	192
	Tek Tesirli-Genel / Single Acting-General	159	283	ES-506	192
	Tek Tesirli-Genel / Single Acting-General	337	461	ES-5013	192
	Tek Tesirli-Alüminyum / Single Acting-Aluminum	54.10	171	ESA-552	177
	Tek Tesirli-Alüminyum / Single Acting-Aluminum	104.90	222	ESA-554	177
50	Tek Tesirli-Alüminyum / Single Acting-Aluminum	155.95	273	ESA-556	177
	Tek Tesirli-Em.somunlu-Alü. / S.Acting-Lock-Al.	152.4	318	ELA-556	188
	Çift Tesirli / Double Acting	156	331	ED-506	182
	Çift Tesirli / Double Acting	334	509	ED-5013	182
	Çift Tesirli / Double Acting	511	733	ED-5020	182
	Tek Tesirli-Yüksek Tonaj / Single Acting-High Ton.	50	162	ESX-502	184
	Tek Tesirli-Yüksek Tonaj / Single Acting-High Ton.	100	212	ESX-504	184
	Tek Tesirli-Yüksek Tonaj / Single Acting-High Ton.	150	262	ESX-506	184
	Tek Tesirli-Yüksek Tonaj / Single Acting-High Ton.	200	312	ESX-508	184
	Tek Tesirli-Yüksek Tonaj / Single Acting-High Ton.	250	362	ESX-5010	184
60	Yüksek Tonaj / Single Acting-High Ton.	300	412	ESX-5012	184
	Çift Tesirli-Yüksek Tonaj / Double Acting-High Ton.	50	162	EDX-502	186
	Çift Tesirli-Yüksek Tonaj / Double Acting-High Ton.	100	212	EDX-504	186
	Çift Tesirli-Yüksek Tonaj / Double Acting-High Ton.	150	262	EDX-506	186
	Çift Tesirli-Yüksek Tonaj / Double Acting-High Ton.	200	312	EDX-508	186
	Çift Tesirli-Yüksek Tonaj / Double Acting-High Ton.	250	362	EDX-510	186
	Çift Tesirli-Yüksek Tonaj / Double Acting-High Ton.	300	412	EDX-5012	186
	Tek Tesirli-Emniyet somunlu / Single Acting-Lock	50	164	EL-502	191
	Tek Tesirli-Emniyet somunlu / Single Acting-Lock	100	214	EL-504	191
	Tek Tesirli-Emniyet somunlu / Single Acting-Lock	150	264	EL-506	191
75	Tek Tesirli-Emniyet somunlu / Single Acting-Lock	200	314	EL-508	191
	Tek Tesirli-Emniyet somunlu / Single Acting-Lock	250	364	EL-5010	191
	Tek Tesirli-Emniyet somunlu / Single Acting-Lock	300	414	EL-5012	191
	Çekiş Silindiri / Pully Cylinder	152	720	ESP-606	192
	Tek Tesirli - Ortası Delik / Single Acting - Hollow	76	247	ESH-603	178
	Tek Tesirli - Ortası Delik / Single Acting - Hollow	153	323	ESH-606	178
	Çift Tesirli - Ortası Delik / Double Acting - Hollow	89	247	EDH-603	180
	Çift Tesirli - Ortası Delik / Double Acting - Hollow	166	323	EDH-606	180
	Çift Tesirli - Ortası Delik / Double Acting - Hollow	257	438	EDH-6010	180
	Tek Tesirli-Düşük yükseklik - Emniyet somunlu / Single Acting-Low Height-Lock	50	125	ELL-602	189
95	Tek Tesirli-Genel / Single Acting-General	156	286	ES-756	192
	Tek Tesirli-Genel / Single Acting-General	333	492	ES-7513	192
	Tek Tesirli-Düşük Yük. / Single Acting-Low Height	16	80	ESL-750	174
	Çift Tesirli / Double Acting	156	347	ED-756	182
	Çift Tesirli / Double Acting	333	525	ED-7513	182
	Tek Tesirli-Genel / Single Acting-General	168	357	ES-1006	192
	Tek Tesirli-Genel / Single Acting-General	260	449	ES-10010	192
	Tek Tesirli - Ortası Delik / Single Acting - Hollow	76	254	ESH-1003	178
	Çift Tesirli - Ortası Delik / Double Acting - Hollow	38	165	EDH-1001	180
	Çift Tesirli - Ortası Delik / Double Acting - Hollow	76	254	EDH-1003	180
100	Çift Tesirli - Ortası Delik / Double Acting - Hollow	153	342	EDH-1006	180
	Çift Tesirli - Ortası Delik / Double Acting - Hollow	257	460	EDH-10010	180
	Çift Tesirli / Double Acting	168	357	ED-1006	182
	Çift Tesirli / Double Acting	333	524	ED-10013	182
	Çift Tesirli / Double Acting	460	687	ED-10018	182
	Tek Tesirli-Düşük Yük. / Single Acting-Low Height	16	86	ESL-1000	174
	Tek Tesirli-Düşük Yük. / Single Acting-Low Height	57	141	ESL-1002	174
	Tek Tesirli-Alüminyum / Single Acting-Aluminum	54.10	197	ESA-1002	177
	Tek Tesirli-Alüminyum / Single Acting-Aluminum	159	298	ESA-1006	177
	Tek Tesirli-Yüksek Tonaj / Single Acting-High Ton.	50	182	ESX-1002	184
Tek Tesirli-Yüksek Tonaj / Single Acting-High Ton.	100	232	ESX-1004	184	

PRATİK SİLİNDİR SEÇİM TABLOSU

CYLINDER QUICK SELECTION CHART

Kapasite Capacity (t)	Silindir Tipi Cylinder Type	Strok Stroke (mm)	Kapalı Yükseklik Collapsed Height (mm)	MODEL	Sayfa no
100	Tek Tesirli-Yüksek Tonaj / Single Acting-High Ton.	150	282	ESX-1006	184
	Tek Tesirli-Yüksek Tonaj / Single Acting-High Ton.	200	332	ESX-1008	184
	Tek Tesirli-Yüksek Tonaj / Single Acting-High Ton.	250	382	ESX-10010	184
	Tek Tesirli-Yüksek Tonaj / Single Acting-High Ton.	300	432	ESX-10012	184
	Tek Tesirli-Emniyet somunlu / Single Acting-Lock	50	187	EL-1002	191
	Tek Tesirli-Emniyet somunlu / Single Acting-Lock	100	237	EL-1004	191
	Tek Tesirli-Emniyet somunlu / Single Acting-Lock	150	287	EL-1006	191
	Tek Tesirli-Emniyet somunlu / Single Acting-Lock	200	337	EL-1008	191
	Tek Tesirli-Emniyet somunlu / Single Acting-Lock	250	387	EL-10010	191
	Tek Tesirli-Emniyet somunlu / Single Acting-Lock	300	437	EL-10012	191
	Çift Tesirli-Yüksek Tonaj / Double Acting-High Ton.	50	179	EDX-1002	186
	Çift Tesirli-Yüksek Tonaj / Double Acting-High Ton.	100	229	EDX-1004	186
	Çift Tesirli-Yüksek Tonaj / Double Acting-High Ton.	150	279	EDX-1006	186
	Çift Tesirli-Yüksek Tonaj / Double Acting-High Ton.	200	329	EDX-1008	186
	Çift Tesirli-Yüksek Tonaj / Double Acting-High Ton.	250	379	EDX-10010	186
	Çift Tesirli-Yüksek Tonaj / Double Acting-High Ton.	300	429	EDX-10012	186
140	Tek Tesirli-Düşük yükseklik -Emniyet somunlu / Single Acting-Low Height-Lock	50	137	ELL-1002	189
	Tek Tesirli-Emniyet somunlu-Alüminyum / Single Acting-Lock - Aluminum	152.4	340	ELA-1006	188
	Çift Tesirli / Double Acting	57	196	ED-1502	182
	Çift Tesirli / Double Acting	156	385	ED-1506	182
	Çift Tesirli / Double Acting	333	582	ED-15013	182
	Çift Tesirli - Ortası Delik / Double Acting - Hollow	203	349	EDH-1508	180
	Tek Tesirli-Yüksek Tonaj / Single Acting-High Ton.	50	196	ESX-1502	184
	Tek Tesirli-Yüksek Tonaj / Single Acting-High Ton.	100	246	ESX-1504	184
	Tek Tesirli-Yüksek Tonaj / Single Acting-High Ton.	150	296	ESX-1506	184
	Tek Tesirli-Yüksek Tonaj / Single Acting-High Ton.	200	346	ESX-1508	184
	Tek Tesirli-Yüksek Tonaj / Single Acting-High Ton.	250	396	ESX-15010	184
	Tek Tesirli-Yüksek Tonaj / Single Acting-High Ton.	300	446	ESX-15012	184
	Tek Tesirli-Emniyet somunlu / Single Acting-Lock	50	209	EL-1502	191
	Tek Tesirli-Emniyet somunlu / Single Acting-Lock	100	259	EL-1504	191
	Tek Tesirli-Emniyet somunlu / Single Acting-Lock	150	309	EL-1506	191
	Tek Tesirli-Emniyet somunlu / Single Acting-Lock	200	359	EL-1508	191
Tek Tesirli-Emniyet somunlu / Single Acting-Lock	250	409	EL-15010	191	
Tek Tesirli-Emniyet somunlu / Single Acting-Lock	300	459	EL-15012	191	
Tek Tesirli-Düşük Yük. / Single Acting-Low Height	16	100	ESL-1500	174	
Çift Tesirli-Yüksek Tonaj / Double Acting-High Ton.	50	196	EDX-1502	186	
Çift Tesirli-Yüksek Tonaj / Double Acting-High Ton.	100	246	EDX-1504	186	
Çift Tesirli-Yüksek Tonaj / Double Acting-High Ton.	150	296	EDX-1506	186	
Çift Tesirli-Yüksek Tonaj / Double Acting-High Ton.	200	346	EDX-1508	186	
Çift Tesirli-Yüksek Tonaj / Double Acting-High Ton.	250	396	EDX-15010	186	
Çift Tesirli-Yüksek Tonaj / Double Acting-High Ton.	300	446	EDX-15012	186	
160	Tek Tesirli-Düşük yükseklik -Emniyet somunlu / Single Acting-Low Height-Lock	45	148	ELL-1602	189
	Tek Tesirli-Emniyet somunlu / Single -Lock	50	243	EL-2002	191
	Tek Tesirli-Emniyet somunlu / Single -Lock	150	343	EL-2006	191
	Tek Tesirli-Emniyet somunlu / Single -Lock	250	443	EL-20010	191
	Çift Tesirli / Double Acting	152	430	ED-2006	182
	Çift Tesirli / Double Acting	330	608	ED-20013	182
	Tek Tesirli-Yüksek Tonaj / Single Acting-High Ton.	50	216	ESX-2002	184
	Tek Tesirli-Yüksek Tonaj / Single Acting-High Ton.	150	316	ESX-2006	184
	Tek Tesirli-Yüksek Tonaj / Single Acting-High Ton.	300	466	ESX-20012	184
	Çift Tesirli-Yüksek Tonaj / Double Acting-High Ton.	50	212	EDX-2002	186
	Çift Tesirli-Yüksek Tonaj / Double Acting-High Ton.	150	312	EDX-2006	186
	Çift Tesirli-Yüksek Tonaj / Double Acting-High Ton.	300	462	EDX-20012	186
	Tek Tesirli-Düşük yükseklik -Emniyet somunlu / Single Acting-Low Height-Lock	45	155	ELL-2002	189
	Tek Tesirli-Yüksek Tonaj / Single Acting-High Ton.	50	235	ESX-2502	184
	Tek Tesirli-Yüksek Tonaj / Single Acting-High Ton.	150	335	ESX-2506	184
	Tek Tesirli-Yüksek Tonaj / Single Acting-High Ton.	300	485	ESX-25012	184
Çift Tesirli-Yüksek Tonaj / Double Acting-High Ton.	50	235	EDX-2502	186	
Çift Tesirli-Yüksek Tonaj / Double Acting-High Ton.	150	335	EDX-2506	186	
Çift Tesirli-Yüksek Tonaj / Double Acting-High Ton.	300	485	EDX-25012	186	
Tek Tesirli-Emniyet somunlu / Single Action -Lock	50	249	EL-2502	191	

Kapasite Capacity (t)	Silindir Tipi Cylinder Type	Strok Stroke (mm)	Kapalı Yükseklik Collapsed Height (mm)	MODEL	Sayfa no
250	Tek Tesirli-Emniyet somunlu / Single Acting-Lock	150	349	EL-2506	191
	Tek Tesirli-Emniyet somunlu / Single Acting-Lock	250	449	EL-25010	191
260	Tek Tesirli-Düşük yükseklik -Emniyet somunlu / Single Acting-Low Height-Lock	45	159	ELL-2502	189
	Çift Tesirli / Double Acting	153	485	ED-3006	182
300	Tek Tesirli-Yüksek Tonaj / Single Acting-High Ton.	50	312	ESX-3002	184
	Tek Tesirli-Yüksek Tonaj / Single Acting-High Ton.	150	412	ESX-3006	184
	Tek Tesirli-Yüksek Tonaj / Single Acting-High Ton.	300	562	ESX-30012	184
	Çift Tesirli-Yüksek Tonaj / Double Acting-High Ton.	50	322	EDX-3002	180
	Çift Tesirli-Yüksek Tonaj / Double Acting-High Ton.	150	422	EDX-3006	180
	Çift Tesirli-Yüksek Tonaj / Double Acting-High Ton.	300	572	EDX-30012	180
	Tek Tesirli-Emniyet somunlu / Single Acting-Lock	50	295	EL-3002	191
	Tek Tesirli-Emniyet somunlu / Single Acting-Lock	150	395	EL-3006	191
	Tek Tesirli-Emniyet somunlu / Single Acting-Lock	250	495	EL-30010	191
	Tek Tesirli-Emniyet somunlu / Single Acting-Lock	50	335	EL-4002	191
	Tek Tesirli-Emniyet somunlu / Single Acting-Lock	150	435	EL-4006	191
	Tek Tesirli-Emniyet somunlu / Single Acting-Lock	250	535	EL-40010	191
	Tek Tesirli-Yüksek Tonaj / Single Acting-High Ton.	50	375	ESX-4002	184
	Tek Tesirli-Yüksek Tonaj / Single Acting-High Ton.	150	475	ESX-4006	184
	Tek Tesirli-Yüksek Tonaj / Single Acting-High Ton.	300	625	ESX-40012	184
	Çift Tesirli-Yüksek Tonaj / Double Acting-High Ton.	50	374	EDX-4002	186
Çift Tesirli-Yüksek Tonaj / Double Acting-High Ton.	150	474	EDX-4006	186	
Çift Tesirli-Yüksek Tonaj / Double Acting-High Ton.	300	624	EDX-40012	186	
Tek Tesirli-Düşük yükseklik -Emniyet somunlu / Single Acting-Low Height-Lock	45	178	ELL-4002	189	
Tek Tesirli-Yüksek Tonaj / Single Acting-High Ton.	50	419	ESX-5002	184	
Tek Tesirli-Yüksek Tonaj / Single Acting-High Ton.	150	519	ESX-5006	184	
Tek Tesirli-Yüksek Tonaj / Single Acting-High Ton.	300	669	ESX-50012	184	
Çift Tesirli-Yüksek Tonaj / Double Acting-High Ton.	50	419	EDX-5002	180	
Çift Tesirli-Yüksek Tonaj / Double Acting-High Ton.	150	519	EDX-5006	180	
Çift Tesirli-Yüksek Tonaj / Double Acting-High Ton.	300	669	EDX-50012	180	
Tek Tesirli-Emniyet somunlu / Single Acting-Lock	50	375	EL-5002	191	
Tek Tesirli-Emniyet somunlu / Single Acting-Lock	150	475	EL-5006	191	
Tek Tesirli-Emniyet somunlu / Single Acting-Lock	250	575	EL-50010	191	
520	Tek Tesirli-Düşük yükseklik -Emniyet somunlu / Single Acting-Low Height-Lock	45	192	ELL-5002	189
	Tek Tesirli-Yüksek Tonaj / Single Acting-High Ton.	50	429	ESX-6002	184
Tek Tesirli-Yüksek Tonaj / Single Acting-High Ton.	150	529	ESX-6006	184	
Tek Tesirli-Yüksek Tonaj / Single Acting-High Ton.	300	679	ESX-60012	184	
Çift Tesirli-Yüksek Tonaj / Double Acting-High Ton.	50	429	EDX-6002	180	
Çift Tesirli-Yüksek Tonaj / Double Acting-High Ton.	150	529	EDX-6006	180	
Çift Tesirli-Yüksek Tonaj / Double Acting-High Ton.	300	679	EDX-60012	180	
Tek Tesirli-Emniyet somunlu / Single Acting-Lock	50	395	EL-6002	191	
Tek Tesirli-Emniyet somunlu / Single Acting-Lock	150	495	EL-6006	191	
Tek Tesirli-Emniyet somunlu / Single Acting-Lock	250	595	EL-60010	191	
Tek Tesirli-Yüksek Tonaj / Single Acting-High Ton.	50	474	ESX-8002	184	
Tek Tesirli-Yüksek Tonaj / Single Acting-High Ton.	150	574	ESX-8006	184	
Tek Tesirli-Yüksek Tonaj / Single Acting-High Ton.	300	724	ESX-80012	184	
Çift Tesirli-Yüksek Tonaj / Double Acting-High Ton.	50	484	EDX-8002	180	
Çift Tesirli-Yüksek Tonaj / Double Acting-High Ton.	150	584	EDX-8006	180	
Çift Tesirli-Yüksek Tonaj / Double Acting-High Ton.	300	734	EDX-80012	180	
Tek Tesirli-Emniyet somunlu / Single Acting-Lock	50	455	EL-8002	191	
Tek Tesirli-Emniyet somunlu / Single Acting-Lock	150	555	EL-8006	191	
Tek Tesirli-Emniyet somunlu / Single Acting-Lock	250	655	EL-80010	191	
Tek Tesirli-Yüksek Tonaj / Single Acting-High Ton.	50	564	ESX-10002	184	
Tek Tesirli-Yüksek Tonaj / Single Acting-High Ton.	150	664	ESX-10006	184	
Tek Tesirli-Yüksek Tonaj / Single Acting-High Ton.	300	814	ESX-100012	184	
Çift Tesirli-Yüksek Tonaj / Double Acting-High Ton.	50	564	EDX-10002	180	
Çift Tesirli-Yüksek Tonaj / Double Acting-High Ton.	150	663	EDX-10006	180	
Çift Tesirli-Yüksek Tonaj / Double Acting-High Ton.	300	814	EDX-100012	180	
Tek Tesirli-Emniyet somunlu / Single Acting-Lock	50	495	EL-10002	191	
Tek Tesirli-Emniyet somunlu / Single Acting-Lock	150	595	EL-10006	191	
Tek Tesirli-Emniyet somunlu / Single Acting-Lock	250	695	EL-100010	191	

ES SERİSİ / ES SERIES

GENEL AMAÇLI TEK TESİRLİ SİLİNDİRLER / GENERAL PURPOSE, SINGLE ACTING CYLINDERS



Soldan sağa doğru modeller / Shown from left to right
ES-1010, ES-256, ES-252, ES-10010,
ES-504, ES-59, ES 2510

Opsiyonel Oynar Piston Başlığı / Optional Tilt Saddle

Kullanılacak Silindir Kapasitesi / For use with Cylinder Capacity	Oynar Piston Başlığı Modeli / Tilt Saddle Model	Kullanılacak Silindir Kapasitesi / For use with Cylinder Capacity	Oynar Piston Başlığı Modeli / Tilt Saddle Model
Metrik Ton / Metric Ton (US Ton)*		Metrik Ton / Metric Ton (US Ton)*	
5 (5.5)	-	30 (33)	ST-50
10 (11)*	ST-10	50 (55)	ST-100
15 (16.5)	ST-10	75 (82.5)	ST-100
25 (27.5)	ST-50	95 (102.3)	ST-100

* ES-101 dışında

Özellikler

- ASME B-30.1 regülasyonuna uygundur. Yüksek kalite çelik alalım sayesinde emniyet ve dayanıklılık artırılmıştır.
- Sertleştirilmiş ve krom kaplanmış piston sayesinde dayanıklılık artırılarak aşınma indirgenmiştir.
- Kolay sabitlemeyi gerçekleştirmek için sıkma bileziği dişleri, piston dişleri ve gövde montaj delikleri.
- Ağır yük pistonu çekme yayları.
- EAB 201 yüksek kalite çabuk bağlantı rakorları.
- Çevre dostu boya ile korozyon dayanımı sağlanmıştır.

Features

- Complies with ASME B-30.1. High strength steel for durability and increased safety.
- Hardened and chromed piston increase durability and reduces wear.
- Collar threads, piston threads and base mounting holes enable easy fixturing.
- Heavy-duty piston return springs.
- High quality EAB 201 quick couplers.
- Environmentally friendly painting process provides a durable anti-corrosion finish.



- Yüksek basınç hortumlarını seçiniz.
Quality pressure hoses



- EV-23 ile birlikte kullanılması önerilen yük taşıyıcı manuel kontrol valfi.
Use with EV-23 manually operated check valve for load holding.



- Aşırı yüklenmeleri önlemek için sistemin çalışma basıncını kontrol etmeye yarayan göstergeyi seçiniz.
Pressure gauges vaible to monitor system pressure.

1. Kılavuz halka merkez dışı yüklerle karşı koruma, destek sağlar ve fazla yükselmeye engel olur.
2. Silindirin toz ve kirlere korunmasını sağlamak, performansını ve servis ömrünü artırmak için toz contası
3. Merkezlenmemiş yüklerde aşınmayı engellemek ve ek destek sağlayan şaft bileziği.
4. Yüksek dayanıma sahip emaye kaplı çelik gövde dayanıklılık için kaplanmıştır.
5. Sertleştirilmiş ve krom kaplanmış piston sayesinde dayanıklılık artırılarak aşınma indirgenmiştir.
6. Sızıntıları önleyen sızdırmaz conta ve endüstriyel keçe.
7. Tüm silindirlerde ağır hizmet toz kapaklı standart bağlantı rakorları.
8. Yüksek dayanıklı dönüş yayı.

1. Guide Ring eliminates over travel, and provides support to reduce wear from off center loads.
2. Heavy duty wiper ring keep duts and debris out of cylinder body, improving performance and service life of cylinder.
3. Bearing ring provides additional support to reduce wear from center loads.
4. All steel body with baked enamel finish for durability.
5. Hardened and chromed piston increase durability and reduces wear.
6. Secondary gasket and industrial seal ring assembly prevent costly leaks.
7. Standard coupler on all cylinders provided with heavy duty dust cover.
8. High strength return spring.



**106 adet ES-306 tek
tesirli silindirler, stator
çekirdeği tutucu
laminenin
preslenmesinde
kullanılmıştır.**



106 pieces of ES-306
single acting cylinders
are used to press the
laminates into stator
core hold-down gear.

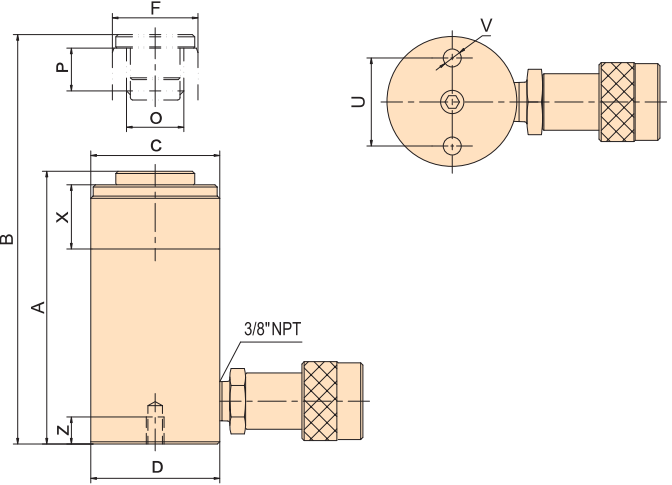

Art. No. / Cod No.	Silindir Kapasitesi @700bar (10,000 PSI) Cylinder Capacity (10,000 PSI)	Strok / Stroke	Model	Silindir Etkelil Alanı / Cylinder Effective Area	Yağ Kapasitesi Oil Capacity	İnmiş Durumda Yükseklik / Collapsed Height	Genişlemiş Durumda Yükseklik / Extended Height	Gövde Diş Çapı / Collar Diam	Gövde Diş Uzunluğu Collar Thread Length	Diş Çapı / Outside Diameter	Piston Mil Çapı Piston Rod Diam.	Piston İç Diş Piston Internal Thread	Piston Diş Uzunluğu/ Piston Thread Length	Tutucu Civ. Delikleri / Base Fix Holes			Ağırlık / Weight
														Civata Merk. mesafesi/ Bolt Circle	Diş / Thread	Diş Derinliği/ Thread Depth	
	ton	mm		cm ²	cm ³	A mm	B mm	C in	X mm	D mm	F mm	O -	P mm	U mm	V in	Z mm	kg
91100001	5	16	ES-50	7,1	11,5	42	58	—	—	59 x 42	25	—	—	28	0,22	—	0.8
91100002		25	ES-51	7,1	17,9	110	135	1 1/2"-16	28	38	25	3/4"-16 UNF	16	25	1/4"-20	14	1.0
91100003		75	ES-53	7,1	53,3	165	240	1 1/2"-16	28	38	25	3/4"-16 UNF	16	25	1/4"-20	14	1.3
91100004		127	ES-55	7,1	90,2	215	342	1 1/2"-16	28	38	25	3/4"-16 UNF	16	25	1/4"-20	14	1.7
91100005		177	ES-57	7,1	125,8	273	450	1 1/2"-16	28	38	25	3/4"-16 UNF	16	25	1/4"-20	14	2.1
91100006		232	ES-59	7,1	164,8	323	555	1 1/2"-16	28	38	25	3/4"-16 UNF	16	25	1/4"-20	14	2.3
91100007	10	26	ES-101	14,5	37,7	89	115	2 1/4"-14	26	57	38	10-24 UNC	6	39	5/16"-18	11,9	1.7
91100008		54	ES-102	14,5	78,4	121	175	2 1/4"-14	26	57	38	1"-8 UNC	19	39	5/16"-185/	11,9	2.2
91100009		105	ES-104	14,5	152,4	171	276	2 1/4"-14	26	57	38	1"-8 UNC	19	39	16"-185/1	11,9	2.9
91100010		156	ES-106	14,5	226,3	247	403	2 1/4"-14	28	57	38	1"-8 UNC	19	39	6"-185/16	11,9	4.1
91100011		203	ES-108	14,5	294,5	298	501	2 1/4"-14	26	57	38	1"-8 UNC	19	39	"-185/16"	11,9	4.9
91100012		257	ES-1010	14,5	372,8	349	606	2 1/4"-14	28	57	38	1"-8 UNC	19	39	185/16"-1	11,9	5.6
91100013		304	ES-1012	14,5	441,0	400	704	2 1/4"-14	26	57	38	1"-8 UNC	19	39	85/16"-10	11,9	6.4
91100014		356	ES-1014	14,5	516,4	450	806	2 1/4"-14	26	57	38	1"-8 UNC	19	39	3/8"-16	11,9	7.2
91100015		25	ES-151	21,2	53,0	124	149	2 3/4"-16	35	70	42	1"-8 UNC	25	47	3/8"-16	11,9	3.2
91100016		51	ES-152	21,2	108,2	149	200	2 3/4"-16	35	70	42	1"-8 UNC	25	47	3/8"-16	11,9	3.7
91100017	15	101	ES-154	21,2	214,2	200	301	2 3/4"-16	35	70	42	1"-8 UNC	25	47	3/8"-16	11,9	5.0
91100018		152	ES-156	21,2	322,4	271	423	2 3/4"-16	35	70	42	1"-8 UNC	25	47	3/8"-16	11,9	6.5
91100019		203	ES-158	21,2	430,5	322	525	2 3/4"-16	35	70	42	1"-8 UNC	25	47	3/8"-16	11,9	7.7
91100020		254	ES-1510	21,2	538,7	373	627	2 3/4"-16	35	70	42	1"-8 UNC	25	47	3/8"-16	11,9	8.7
91100021		305	ES-1512	21,2	646,8	423	728	2 3/4"-16	35	70	42	1"-8 UNC	25	47	3/8"-16	11,9	9.8
91100022		356	ES-1514	21,2	755,1	474	830	2 3/4"-16	35	70	42	1"-8 UNC	25	47	1/2"-13	11,9	10.8
91100023		26	ES-251	33,2	86,4	139	165	3 5/16"-12	54	86	57	1 1/2"-16 UN	26	58	1/2"-13	19,1	5.3
91100024		50	ES-252	33,2	166,1	165	215	3 5/16"-12	54	86	57	1 1/2"-16 UN	26	58	1/2"-13	19,1	6.2
91100025	25	102	ES-254	33,2	338,8	215	317	3 5/16"-12	54	86	57	1 1/2"-16 UN	26	58	1/2"-13	19,1	8.0
91100026		158	ES-256	33,2	524,8	273	431	3 5/16"-12	54	86	57	1 1/2"-16 UN	26	58	1/2"-13	19,1	10.3
91100027		210	ES-258	33,2	697,5	323	533	3 5/16"-12	54	86	57	1 1/2"-16 UN	26	58	1/2"-13	19,1	12.1
91100028		261	ES-2510	33,2	866,9	374	635	3 5/16"-12	54	86	57	1 1/2"-16 UN	26	58	1/2"-13	19,1	14.1
91100029		311	ES-2512	33,2	1032,9	425	736	3 5/16"-12	54	86	57	1 1/2"-16 UN	26	58	1/2"-13	19,1	15.5
91100030		362	ES-2514	33,2	1202,3	476	838	3 5/16"-12	54	86	57	1 1/2"-16 UN	26	58		19,1	17.4
91100031	30	209	ES-308	44,2	924,1	387	596	3 5/16"-12	50	105	57	1 1/2"-16 UN	26	60	1/2"-13		21.5
91100032	50	51	ES-502	70,9	361,8	176	227	5"-12	55	127	80	—	—	95	1/2"-13	19,1	14.4
91100033		102	ES-504	70,9	723,4	227	329	5"-12	55	127	80	—	—	95	1/2"-13	19,1	18.1
91100034		159	ES-506	70,9	1127,8	282	441	5"-12	55	127	80	—	—	95	1/2"-13	19,1	22.2
91100035		337	ES-5013	70,9	2390,3	460	797	5"-12	55	127	80	—	—	95		19,1	34.3
91100036	75	156	ES-756	103,9	1621,5	285	441	5 3/4"-12	45	146	95	—	—	—			30.5
91100037		333	ES-7513	103,9	3461,2	492	825	5 3/4"-12	45	146	95	—	—	—	3/4"-10		50.3
91100038	90	168	ES-1006	133	2235,3	357	525	6 7/8"-12	44	177	105	—	—	139	3/4"-10	24,9	59.6
91100039		260	ES-10010	133	3459,4	449	709	6 7/8"-12	44	177	105	—	—	139		24,9	72.8

ESL SERİSİ / ESL SERIES

TEK TESİRLİ DÜŞÜK YÜKSEKLİK Lİ SİLİNDİRLER SINGLE ACTING, LOW HEIGHT CYLINDERS



Soldan sağa doğru modeller / Shown from left to right
ESL-1002, ESL-302, ESL-500, ESL-50, ESL-300

Özellikler

- Sınırlı alanlarda kullanım kolaylığı sağlar.
- ASME B-30.1 regülasyonuna uygundur.
- Yüksek kalite çelik alaşım sayesinde emniyet ve dayanıklılık artırılmıştır.
- Montaj delikleri kolayca sabitlemenizi sağlar.
- Ağır yük pistonu çekme yayları.
- EAB 201 yüksek kalite çabuk bağlantı rakorları.
- Yivli piston yapısı, piston başlığı gerektirmez.
- Çevre dostu boya ile korozyon dayanımı sağlanmıştır.

Features

- Use in confined spaces.
- Complies with ASME B-30.1. High strength steel for durability and increased safety.
- Mounting holes permit easy fixturing.
- Heavy-duty piston return springs.
- High quality EAB 201 quick couplers.
- Grooved piston end requires no saddle.
- Environmentally friendly painting process provides a durable anti-corrosion finish.

Kod No / Code No	Silindir Kapasitesi @700bar / Cylinder Capacity (10,000 PSI)	Strok / Stroke mm	Model	Silindir Etketif Alanı / Cylinder Effective Area cm ²	Yağ Kapasitesi / Oil Capacity cm ³	İnmiş Durumda Yükseklik / Collapsed Height		Genişlemiş DurumdaYükseklik / Extended Height	
						A	B	A	B
						mm	mm	mm	mm
91110001	5	6	ESL-50*	7,1	4,3	33	39		
91110002	10	10	ESL-100	14,5	14,4	42	53		
91110003	20	11	ESL-200	28,3	31,2	51	62		
91110004	30	13	ESL-300	41,8	54,3	58	71		
91110005	50	16	ESL-500	63,6	101,8	67	83		
91110006	75	16	ESL-750	103,9	166,3	79	95		
91110007	100	16	ESL-1000	132,7	212,5	86	102		
91110008	150	16	ESL-1500	201,1	321,9	100	116		

ESL SERİSİ / ESL SERIES



Köprüyü istenen pozisyona getirmek için elektrik pompaları ile birlikte 24 adet silindir kullanılmıştır.

24 hydraulic cylinders with an electric hydraulic pump lift a bridge into position.

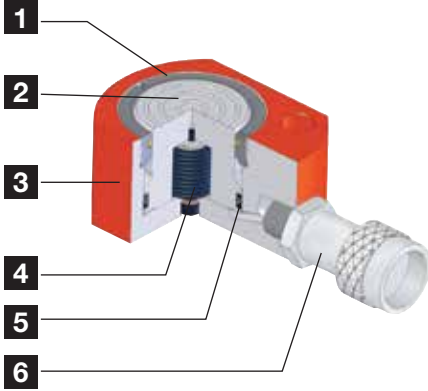

1. Kılavuz halka merkez dışı yüklerle karşı koruma, destek sağlar ve fazla yükselmeye engel olur.
2. Sertleştirilmiş ve krom kaplanmış piston sayesinde dayanıklılık artırılarak aşınma indirgenmiştir.
3. Yüksek dayanıma sahip emaye kaplı çelik gövde dayanıklılık için kaplanmıştır.
4. Yüksek dayanıklı dönüş yayı.
5. Sızıntıları önleyen sızdırmaz conta ve endüstriyel keçe.
6. Tüm silindirlere ağır hizmet toz kapaklı standart bağlantı rakorları.

1. Steel guide ring eliminates over travel and withstands full dead end load, it also provides support to reduce wear from off center loads.
2. Hardened and chromed piston increase durability and reduces wear.
3. All steel body with baked enamel finish for durability.
4. High strength return spring.
5. Secondary gasket and industrial seal ring assembly prevent costly leaks.
6. Standard coupler on all cylinders provided with heavy duty dust cover.

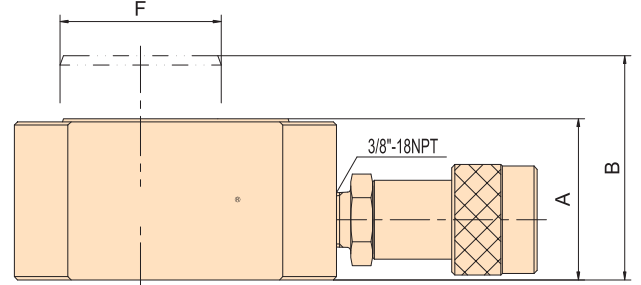
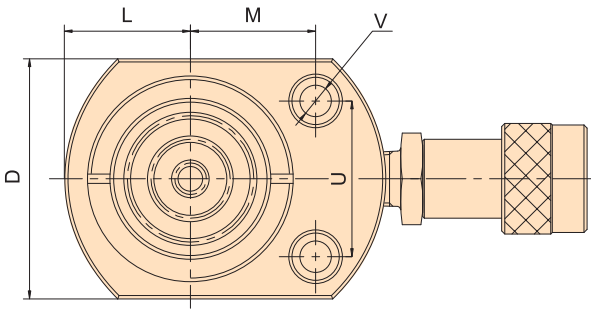

Not: ESL-50 de EAB 203A kaplin, diğer modellerde EAB 201A kaplin kullanılmıştır.
ESL-50 has EAB-203A coupler, the other models have EAB-201A coupler.

Dış Çap / Outside Diameter	Piston Mil Çapı / Piston Rod Diam.	Üst Ölçüler / Upside Dimension				Ağırlık / Weight
		M	L	V	U	
D	F	M	L	V	U	kg
mm	mm	mm	mm	mm	mm	kg
59 x 42	25	23	21	5,6	28,4	0,6
83 x 56	38	34	28	7,1	36,6	1,5
102 x 76	51	40	40	19,9	49,3	2,7
117 x 95	66	45	48	9,9	52,1	4,3
140 x 114	70	54	57	10,9	66,5	6,7
165 x 139	83	66	69	13,5	76,2	11,4
178 x 153	92	74	76	13,5	76,2	14,5
215 x 190	115	82	95	13,5	117,3	26,3

ESL SERİSİ / ESL SERIES

Özellikler

- Düşük yükseklik ve özellikli tasarımı ile sınırlı çalışma alanlarında kullanım olanağı sağlar.
- ASME B-30.1 regülasyonuna uygundur. Yüksek kalite çelik alaşım sayesinde emniyet ve dayanıklılık artırılmıştır.
- Tek tesirli, dönüş yayı.
- EAB 201 yüksek kalite çabuk bağlantı rakorları.
- Oynar piston başlığı montajı için civata delikli oluklu piston uçları.
- Çevre dostu boya ile korozyon dayanımı sağlanmıştır.

Features

- Low profile design for use in confined spaces.
- Complies with ASME B-30.1. High strength steel for durability and increased safety.
- Single-acting spring return.
- High quality EAB 201 quick couplers.
- Grooved piston ram with threaded holes for mounting tilt saddles.
- Environmentally friendly painting process provides a durable anti-corrosion finish.

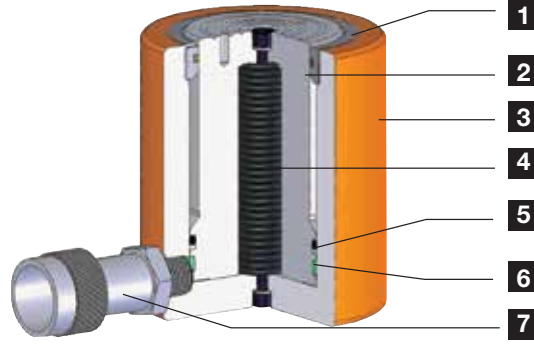
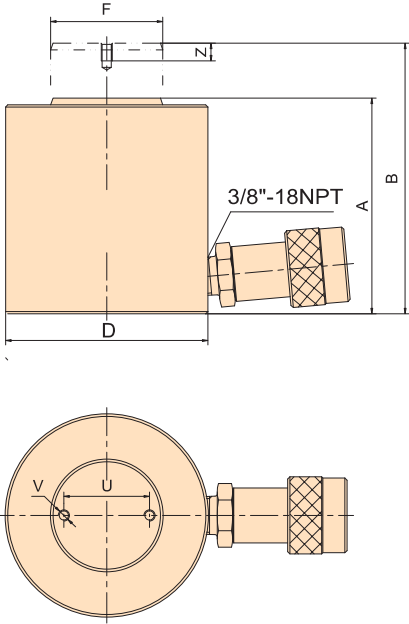

1. Kılavuz halka merkez dışı yüklerle karşı koruma, destek sağlar ve fazla yükselmeye engel olur.
2. Sertleştirilmiş ve krom kaplanmış piston sayesinde dayanıklılık artırılarak aşınma indirilmiştir.
3. Yüksek dayanıma sahip emaye kaplı çelik gövde dayanıklılık için kaplanmıştır.
4. Yüksek dayanıklı dönüş yayı.
5. Sızıntıları önleyen endüstriyel keçe.
6. Merkezlenmemiş yüklerde aşınmayı engellemek ve ek destek sağlayan şaft bileziği.
7. Tüm silindirlere ağır hizmet toz kapaklı standart bağlantı rakorları.

1. Steel guide ring eliminates over travel and provides additional support to reduce wear from off center loads.
2. Hardened and chromed piston increase durability and reduces wear.
3. All steel body with baked enamel finish for durability.
4. High strength return spring.
5. Industrial seal ring assembly prevent costly leaks.
6. Bearing ring provides additional support to reduce wear from off center loads.
7. Standard coupler on all cylinders provided with heavy duty dust cover.

Opsiyonel Oynar Piston Başlığı /

Optional Tilt Saddle

Silindir Model / Cylinder Model	Oynar Piston Başlığı Modeli / Tilt Saddle Model
ESL-101	ST-11
ESL-201, 302, 502	ST-51
ESL-1002	ST-101

Kod no / Code No	Silindir Kapasitesi @700bar Cylinder Capacity	Strok / Stroke	Model	Silindir Etketif Alanı / Cylinder Effective Area	Yağ Kapasitesi / Oil Capacity	Inmiş Durumda Yükseklik / Collapsed Height	Genişleşmiş Durumda Yükseklik/ Extended Height	Dış Çap / Outside Diameter	Piston Mil Çapı / Piston Rod Diam.	Üst Ölçüler/ Upside Dimension			Ağırlık / Weight		
						A	B			D	F	Dış / Thread		Civata Mrk.mes. Bolt Circle	Dış Derinliği / Thread Depth
						mm	mm			mm	mm	mm		mm	mm
91110009	10	38	ESL-101	14,4	54,8	88	126	69	38	M4	26	8	4,1		
91110010	20	45	ESL-201	28,3	127,4	98	143	92	51	M5	39	8	4,7		
91110011	30	62	ESL-302	41,8	259,3	117	179	102	66	M5	39	8	6,8		
91110012	50	60	ESL-502	63,6	381,8	122	182	124	70	M5	39	8	10,1		
91110013	100	57	ESL-1002	132,7	757,2	141	198	165	92	M8	55	11	19,2		

ESA SERİSİ / ESA SERIES**TEK TESİRLİ ALÜMİNYUM SİLİNDİRLER**
SINGLE ACTING, ALUMINUM CYLINDERS

Soldan sağa doğru modeller / Shown from left to right
ESA-202 / ESA-304

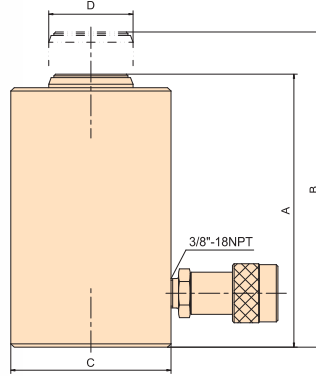
**Özellikler**

- Düşük ağırlıkta ve taşınması kolay.
- Korozyon ve aşınma dayanımına sahip ve özel işlemlerden geçirilmiş yüksek mukavemetli alüminyum malzeme.
- Zor çevresel şartlarda kullanım olanağı.
- Tek tesirli, dönüş yayı.

Features

- Low weight, easy to carry.
- High strength aluminum material treated to resist wear and corrosion.
- For use in extreme environment.
- Single acting, spring return.

1. Kılavuz halka pistonun limitinde durmasını sağlar ve merkezlenmemiş yüklerde destek görevi üstlenir.
2. Yüksek mukavemetli alüminyum alaşımlı gövde korozyona karşı koruma sağlayacak şekilde kaplanmıştır.
3. Yüksek mukavemetli, düz inen dönüş yayı hızlı hareket eder.
4. Ürün üzerinde toz kapaklı standart kaplin bulunur.
5. Yüksek mukavemetli kompozit rulmanlar merkezlenmemiş yüklerle karşı destek görevi sağlar ve silindir duvarlarının hasar görmesini önler.

1. Guide ring allows the piston to stop at its limit and it acts as a support for decentralized loads.
2. High strength aluminum alloy body is resistant to corrosion coated to protect against.
3. High strength, flat descending return spring moves fast.
4. There is a standard coupling with dust cover on the product.
5. High strength composite bearings are not centered provides support against loads and ensures that the cylinder wall prevents damage.

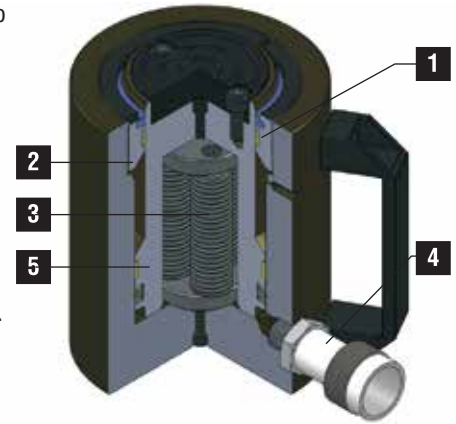

Kod no / Code No	Silindir Kapasitesi @700bar Cylinder Capacity	Strok / Stroke	Model	Silindir Efektif Alanı / Cylinder Effective Area	Yağ Kapasitesi / Oil Capacity	İnmiş Durumda Yükseklik / Collapsed Height		Genişleşmiş Durumda Yükseklik/ Extended Height	Dış Çap / Outside Diameter	Piston Mil Çapı / Piston Rod Diam.	Ağırlık / Weight
						A	B				
	ton	mm		cm ²	cm ³	mm	mm	mm	mm	kg	
91120001	20	54	ESA-202	28,3	152,9	162	216	95	50	3,5	
91120002		105	ESA-204	28,3	297,3	213	318	95	50	4,3	
91120003		156	ESA-206	28,3	441,48	263	420	95	50	5,2	
91120004	30	54	ESA-302	44,2	238,7	188	242	109	65	5,2	
91120005		105	ESA-304	44,2	464,3	238	343	109	65	6,1	
91120006		156	ESA-306	44,2	689,8	289	445	109	65	7,6	
91120007	50	54	ESA-552	70,9	382,9	172	226	134	80	7,2	
91120008		105	ESA-554	70,9	744,7	222	327	134	80	8,9	
91120009		156	ESA-556	70,9	1106,5	273	429	134	80	10,9	
91120010	100	54	ESA-1002	133,0	718,5	197	251	188	105	15,8	
91120011		159	ESA-1006	133,0	2115,6	299	458	188	105	22,5	

ESH SERİSİ / ESH SERIES

TEK TESİRLİ ORTASI DELİK SİLİNDİRLER SINGLE ACTING HOLLOW CENTER CYLINDERS



ESH-302

ESH-120

Özellikler

- Delikli piston tasarımı itme ve çekme güçlerine izin verir.
- ASME B-30.1 regülasyonuna uygundur.
Yüksek kalite çelik alaşım sayesinde emniyet ve dayanıklılık artırılmıştır.
- Tek tesirli, dönüş yayı.
- EAB 201 yüksek kalite çabuk bağlantı rakorları.
- Kolay monte edilebilir sıkma bileziği dişleri ve piston.
- Çevre dostu boya ile korozyon dayanımı sağlanmıştır.

Features

- Hollow piston design allows for both pull and push forces.
- Complies with ASME B-30.1. High strength steel for durability and increased safety.
- Single acting, spring return.
- High quality EAB 201 quick couplers.
- Collar threads, piston threads for easy fixturing.
- Environmentally friendly painting process provides a durable anti-corrosion finish.

► Opsiyonel Isıl İşlemli Ortası Delik Başlık / Optional Heat Treated Hollow Saddles

Silindir Model / Cylinder Model	Oynar Piston Başlığı Modeli / Tilt Saddle Model	Oynar Piston Başlığı Ölçüleri / Saddle Dimensions			
		A	B	V	D
		mm	in	mm	in
ESH-202,206	SH-2015	55	1"-8UNC	9	1 9/16"-16UN
ESH-302,306	SH-3015	63	1 1/4"-7UN	9	1 13/16"-16UN
ESH-603,606	SH-5016	91	1 5/8"-5 1/2UN	12	2 3/4"-16UN
ESH-1003	SH-10016	126	2 1/2"-8UN	12	4"-16UN

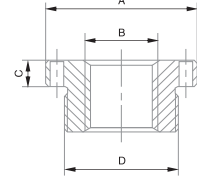

Kod no / Code No	Silindir Kapasitesi @700bar Cylinder Capacity	Strok / Stroke	Model	Silindir Etketif Alanı / Cylinder Effective Area	Yağ Kapasitesi / Oil Capacity	İnmiş Durumda Yükseklik / Collapsed Height	Genişleşmiş Durumda Yükseklik/ Extended Height	Sıkma Gövde/ Collar Thread	Gövde Diş Uzu. / Collar Thread Length	Dış Çap / Outside Diameter
		mm	cm ²		cm ³	mm	mm	in	mm	mm
91130001	13	8	ESH-120*	18,5	14,8	55	63	2 3/4"-16	30	70
91130002		42	ESH-121*	18,5	77,7	120	162	2 3/4"-16	30	70
91130004		76	ESH-123*	18,5	140,6	184	260	2 3/4"-16	30	70
91130005	20	49	ESH-202	32,8	160,7	162	211	3 7/8"-12	38	99
91130006		155	ESH-206	32,8	508,6	306	461	3 7/8"-12	38	99
91130007	30	64	ESH-302	47,7	305,4	178	242	4 1/2"-12	42	115
91130008		155	ESH-306	47,7	739,6	330	485	4 1/2"-12	42	115
91130009	60	76	ESH-603	87,5	665,4	246	322	6 1/4"-12	48	159
91130010		153	ESH-606	87,5	1338,2	323	476	6 1/4"-12	48	159
91130011	95	76	ESH-1003	135,3	1028,8	254	330	8 3/8"-12	60	212

ESH SERİSİ / ESH SERIES

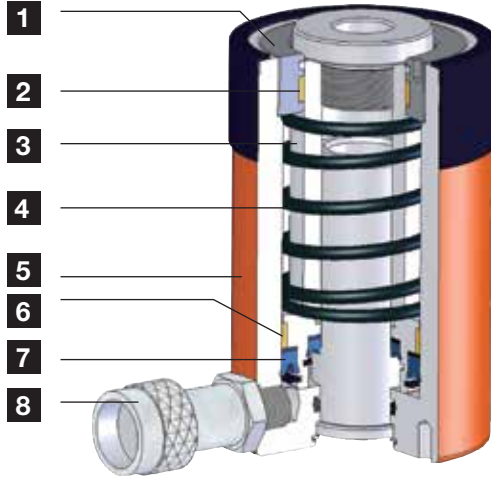

1. Kılavuz halka merkez dışı yüklerle karşı koruma, destek sağlar ve fazla yükselmeye engel olur.
2. Merkezlenmemiş yüklerde aşınmayı engellemek ve ek destek sağlayan şaft bileziği.
3. Sertleştirilmiş ve krom kaplanmış piston sayesinde dayanıklılık artırılarak aşınma indirmişdir.
4. Yüksek dayanıklı dönüş yayı.
5. Yüksek dayanıma sahip emaye kaplı çelik gövde dayanıklılık için kaplanmışdır.
6. Merkezlenmemiş yüklerde aşınmayı engellemek ve ek destek sağlayan şaft bileziği.
7. Sızıntıları önleyen endüstriyel keçe.
8. Tüm silindirlere ağır hizmet toz kapaklı standart bağlantı rakorları.

1. Steel guide ring eliminates over travel and provides additional support to reduce wear from off center loads.
2. Bearing ring provides additional support to reduce wear from off center loads.
3. Hardened and chromed piston increase durability and reduces wear.
4. High strength return spring.
5. All steel body with baked enamel finish for durability.
6. Industrial bearing ring provides additional support to reduce wear from off center loads.
7. Industrial seal ring assembly prevent costly leaks.
8. Standard coupler on all cylinders provided with heavy duty dust cover.



SONDEX firmasındaki eşanjörlerde H serisi ürünler kullanılmaktadır.

ESH series are being used to pull the threaded bar on the largest heat-exchanger in SONDEX's factory.

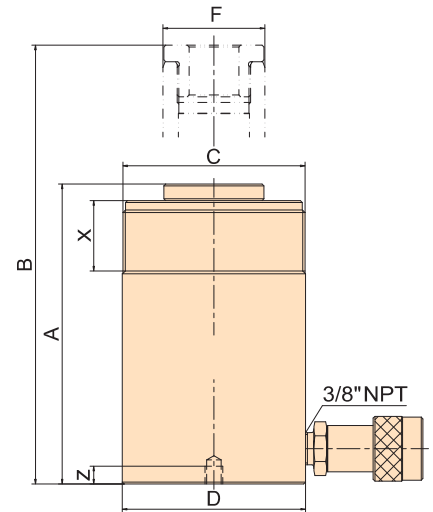
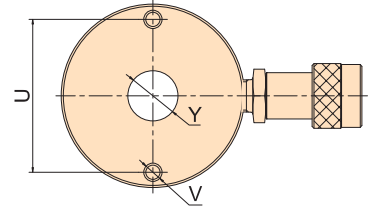

NOT: ESH-120, ESH-121 ve ESH-123 üzerine EAB 202A kaplin ve 1/4\"/>

Piston Mil Çapı / Piston Rod Diam.	Piston İç Diş Çapı / Outside/Inside Diameter	Piston Diş Uzunluğu / Piston Thread	Tutucu Civata Delikleri			Merkez Deliği Çapı / Center Hole Dimanter	Ağırlık / Weight
			Civata Merk. Mesafesi / Bolt Circle	Diş / Thread	Diş Derinliği / Thread Depth		
F		P	U	V	Z	Y	
mm	in	mm	mm	UNC	mm	mm	kg
35	3/4"-16UN	16	51	5/16"-18	9	20	1,5
35	-	-	—	—	—	20	2,8
35	-	-	51	5/16"-18	9	20	4,4
55	1-9/16"-16UN	19	83	3/8"-16	9	27	7,3
55	1-9/16"-16UN	19	83	3/8"-16	9	27	13,4
65	1-13/16"-16UN	22	92	3/8"-16	14	33	10,5
65	1-13/16"-16UN	22	92	3/8"-16	14	33	19,3
92	2-3/4"-16UN	19	130	1/2"-13	14	54	27,4
92	2-3/4"-16UN	19	130	1/2"-13	14	54	34,8
127	4"-16UN	25	178	5/8"-11	20	79	59,4

EDH SERİSİ / EDH SERIES

ÇİFT TESİRLİ ORTASI DELİK SİLİNDİRLER DOUBLE ACTING, HOLLOW CENTER CYLINDERS



Soldan sağa doğru modeller / Shown from left to right
EDH-3010, EDH-603, EDH-6010

Özellikler

- Delikli piston tasarımı itme ve çekme güçlerine izin verir.
- ASME B-30.1 regülasyonuna uygundur. Yüksek kalite çelik alaşım sayesinde emniyet ve dayanıklılık artırılmıştır.
- Hızlı iniş için çift tesirli işleyiş.
- Gövde üzerindeki emniyet vanası aşırı basınç yüklenmesinde meydana gelebilecek kazaları engeller.
- EAB 201 yüksek kalite çabuk bağlantı rakorları.
- Kolay monte edilebilir sıkma bileziği dişleri ve piston.
- Çevre dostu boya ile korozyon dayanımı sağlanmıştır.

Features

- Hollow piston design allows for both pulling and pushing actions.
- Complies with ASME B-30.1. High strength steel for durability and increased safety.
- Double acting operation for fast piston retraction.
- Built-in safety valve prevents accidental over-pressurization.
- High quality EAB 201 quick couplers.
- Collar and piston threads for easy fixturing.
- Environmentally friendly painting process provides a durable corrosion resistant finish.

Opsiyonel Isıl İşlemli Ortası Delik Başlık / Optional Heat Treated Hollow Saddles

Silindir Model / Cylinder Model	Piston Model Numarası / Saddle Model Number	Oynar Piston Başlığı Ölçüleri / Saddle Dimensions			
		A	B	C	D
		mm	in	mm	in
EDH-307,3010	SH-3015	63	1 1/4"-7UN	9	1 13/16"-16UN
EDH-603,606,6010	SH-5016	91	1 5/8"-5 1/2UN	12	2 3/4"-16UN
EDH-1001, 1003, 1006, 10010	SH-10016	126	2 1/2"-8UN	12	4"-16UN

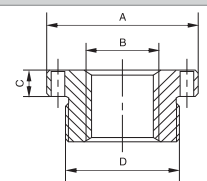

Kod no / Code No	Silindir Kapasitesi @700bar Cylinder Capacity (10.000 PSI) ton	Strok / Stroke mm	Model	Maks.Silindir Kapasitesi / Max.Cylinder Capacity		Silindir Efektif Alanı / Cylinder Effective Area		Yağ Kapasitesi / Oil Capacity		İnmiş Durumda Yükseklik / Collapsed Height A mm
				İleri / Advance ton	Geri/ Retract ton	İleri / Advance cm2	Geri / Retract cm2	İleri / Advance cm3	Geri / Retract cm3	
91140001	30	178	EDH-307	36	25	47,7	32,4	849,4	577,3	330
91140002		258	EDH-3010	36	25	47,7	32,4	1231,2	836,4	431
91140003	60	89	EDH-603	66	43	87,5	56,2	779,0	481,2	246
91140004		166	EDH-606	66	43	87,5	56,2	1453,0	891,3	323
91140005		257	EDH-6010	66	43	87,5	56,2	2249,6	1388,6	438
91140006	95	38	EDH-1001	102	66	135,3	87,1	514,3	331,1	165
91140007		76	EDH-1003	102	66	135,3	87,1	1028,8	662,2	254
91140008		153	EDH-1006	102	66	135,3	87,1	2071,0	1333,5	342
91140009		257	EDH-10010	102	66	135,3	87,1	3478,6	2239,9	460
91140010	150	203	EDH-1508	149	64	197,0	102,0	4000,8	2074,8	349

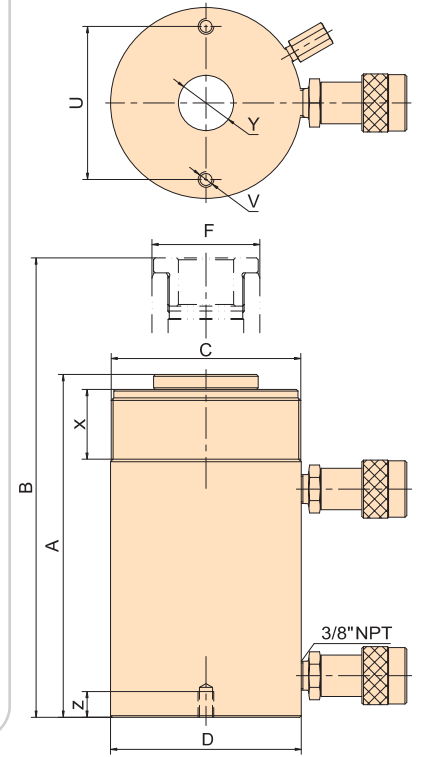
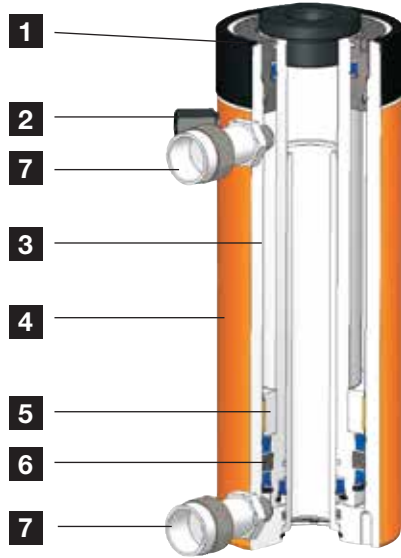
EDH SERİSİ / EDH SERIES

1. Kılavuz halka merkez dışı yüklerle karşı koruma, destek sağılar ve fazla yükselmeye engel olur.
 2. Aşırı yüklenmeyi önlemek için emniyet valfi otomatik tahliye sistemi devreye girer.
 3. Sertleştirilmiş ve krom kaplanmış piston sayesinde dayanıklılık artırılarak aşınma indirgenmiştir.
 4. Yüksek dayanıma sahip emaye kaplı çelik gövde dayanıklılık için kaplanmıştır.
 5. Merkezlenmemiş yüklerde aşınmayı engellemek ve ek destek sağlayan şaft bileziği.
 6. Sızıntıları önleyen endüstriyel keçe.
 7. Tüm silindirlere ağır hizmet toz kapaklı standart bağlantı rakorları.
1. Steel guide ring eliminates over travel and also provides support to reduce wear from off center loads.
 2. Safety valve automatic release the pressure to avoid overload.
 3. Hardened and chromed piston increase durability and reduces wear.
 4. All steel body with baked enamel finish for durability.
 5. Industrial bearing ring provides additional support to reduce wear from off center loads.
 6. Industrial seal ring assembly prevent costly leaks.
 7. Standard coupler on all cylinders provided with heavy duty dust cover.

Genişlemiş Durumda Yükseklik / Extended Height	Sıkma Gövde / Collar Thread		Dış Çap / Outside Diameter	Piston Mil Çapı / Piston Rod Diam.	Piston İç Dış Çapı / Piston Outside / Inside Diameter	Piston Dış Uzunluğu / Piston Thread	Tutucu Civata Delikleri / Base Fix Holes			Merkez Deliği Çapı / Center Hole Diameter	Ağırlık / Weight
	C	X					Civata Merk. mesafesi / Bolt Circle	Diş / Thread	Diş Derinliği / Thread Depth		
B	C	X	D	F	O	P	U	V	Z	Y	
mm	in	mm	mm	mm	in	mm	mm	in	mm	mm	kg
508	4 1/2"-12 UN	42	115	65	1 13/16"-16	559	92	3/8"-16 UNC	15,5	33,3	18,3
689	4 1/2"-12 UN	42	115	65	1 13/16"-16	559	92	3/8"-16 UNC	15,5	33,3	24,5
335	6 1/4"-12 UNC	48	159	92	2 3/4"-16	483	130	1/2"-13 UNC	14	53,8	27,2
489	6 1/4"-12 UNC	48	159	92	2 3/4"-16	483	130	1/2"-13 UNC	14	53,8	34,2
695	6 1/4"-12 UNC	48	159	92	2 3/4"-16	635	130	1/2"-13 UNC	14	53,8	46,9
203	8 3/8"-12 UN	—	212	127	4"-16	635	178	5/8"-11 UNC	20	79	37,0
330	8 3/8"-12 UN	60	212	127	4"-16	635	178	5/8"-11 UNC	20,1	79	55,4
495	8 3/8"-12 UN	60	212	127	4"-16	635	178	5/8"-11 UNC	20,1	79	70,9
717	8 3/8"-12 UN	60	212	127	4"-16	635	178	5/8"-11 UNC	20,1	79	92,4
552	—	—	247	150	4 1/4"-12	635	—	—	—	79,2	102,9

ED SERİSİ / ED SERIES

ÇİFT TESİRLİ SİLİNDİRLER DOUBLE ACTING CYLINDERS

Soldan sağa
doğru modeller /
Shown from left to right
ED-506, ED-7513



Özellikler

- ASME B-30.1 regülasyonuna uygundur. Yüksek kalite çelik alaşım sayesinde emniyet ve dayanıklılık artırılmıştır.
- Hızlı iniş için çift tesirli işleyiş.
- Gövde üzerindeki emniyet vanası aşırı basınç yüklenmesinde meydana gelebilecek kazaları engeller.
- EAB 201 yüksek kalite çabuk bağlantı rakorları.
- Kolay monte edilebilir sıkma bileziği dişleri ve piston.
- Çevre dostu boya ile korozyon dayanımı sağlanmıştır.

Features

- Complies with ASME B-30.1. High strength steel for durability and increased safety.
- Double acting operation for fast retraction.
- Built-in safety valve prevents accidental over-pressurization.
- High quality EAB 201 quick couplers.
- Collar and piston threads for easy fixturing.
- Environmentally friendly painting process provides a durable corrosion resistant finish.

► Opsiyonel Oynar Piston Başlığı / Optional Tilt Saddle

Silindir Model / Cylinder Model	Oynar Piston Başlığı Modeli / Tilt Saddle Model
ED-308, 3014	ST-50
ED-506, 5013, 5020, 756, 7513	ST-100

Kod no / Code No	Silindir Kapasitesi @700bar Cylinder Capacity (10.000 PSI) ton	Strok / Stroke mm	Model	Maks.Silindir Kapasitesi / Max.Cylinder Capacity		Silindir Efektif Alanı / Cylinder Effective Area		Yağ Kapasitesi / Oil Capacity	
				İleri / Advance ton	Geri / Retract ton	İleri / Advance cm2	Geri / Retract cm2	İleri / Advance cm3	Geri / Retract cm3
91150001	10 (11)	254	ED-1010	10 (11)	4 (4,4)	14,5	4,9	368,5	124,5
91150002		305	ED-1012	10 (11)	4 (4,4)	14,5	4,9	442,5	149,6
91150003	30 (33)	209	ED-308	30 (33)	6 (6,6)	41,9	18,1	876,1	378,5
91150004		368	ED-3014	30 (33)	6 (6,6)	41,9	18,1	1542,6	666,3
91150005	50 (55)	156	ED-506	50 (55)	16 (17,6)	70,9	20,6	1106,5	321,4
91150006		334	ED-5013	50 (55)	16 (17,6)	70,9	20,6	2368,0	688,3
91150007		511	ED-5020	50 (55)	16 (17,6)	70,9	20,6	3624,4	1053,0
91150008	75 (82.5)	156	ED-756	75 (82,5)	25 (27,5)	103,9	33	1621,5	515,0
91150009		333	ED-7513	75 (82,5)	25 (27,5)	103,9	33	3461,2	1099,3
91150010	95 (104.5)	168	ED-1006	95 (104,5)	48 (52,8)	133	61,9	2235,3	1040,4
91150011		333	ED-10013	95 (104,5)	48 (52,8)	133	61,9	4430,6	2061,1
91150012		460	ED-10018	95 (104,5)	48 (52,8)	133	61,9	6120,5	2847,5
91150013	140 (154)	57	ED-1502	140 (154)	75 (82,5)	201	97,2	1146,2	554,3
91150014		156	ED-1506	140 (154)	75 (82,5)	201	97,2	3136,8	1517,3
91150015		333	ED-15013	140 (154)	75 (82,5)	201	97,2	6696,0	3238,0
91150017	200 (220)	152	ED-2006	200 (220)	108(118,8)	283,4	140,4	4310,9	2135,1
91150018		330	ED-20013	200 (220)	108(118,8)	283,4	140,4	9359,3	4635,1
91150019		300	ED-3006	300 (330)	184(202,4)	452,3	238,6	6924,4	3652,1

ED SERİSİ / ED SERIES

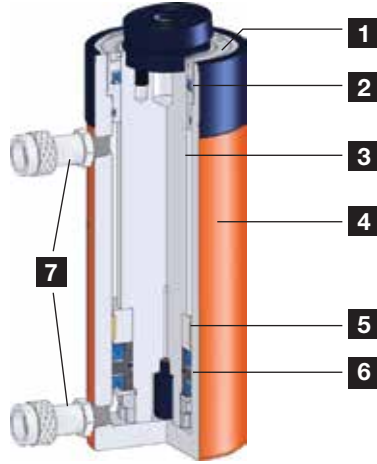

1. Kılavuz halka merkez dışı yüklerle karşı koruma, destek sağlar ve fazla yükselmeye engel olur.
2. Sızıntıları önleyen endüstriyel keçe.
3. Sertleştirilmiş ve krom kaplanmış piston sayesinde dayanıklılık artırılarak aşınma indirgenmiştir.
4. Yüksek dayanıma sahip emaye kaplı çelik gövde dayanıklılık için kaplanmıştır.
5. Merkezlenmemiş yüklerde aşınmayı engellemek ve ek destek sağlayan şaft bileziği.
6. Sızıntıları önleyen endüstriyel keçe.
7. Tüm silindirlere ağır hizmet toz kapaklı standart bağlantı rakorları.

1. Steel guide ring eliminates over travel and also provides additional support to reduce wear from off center loads.
2. Industrial seal ring assembly prevent costly leaks.
3. Hardened and chromed piston increase durability and reduces wear.
4. All steel body with baked enamel finish for durability.
5. Industrial bearing ring provides additional support to reduce wear from off center loads.
6. Industrial seal ring assembly prevent costly leaks.
7. Standard coupler on all cylinders provided with heavy duty dust cover.

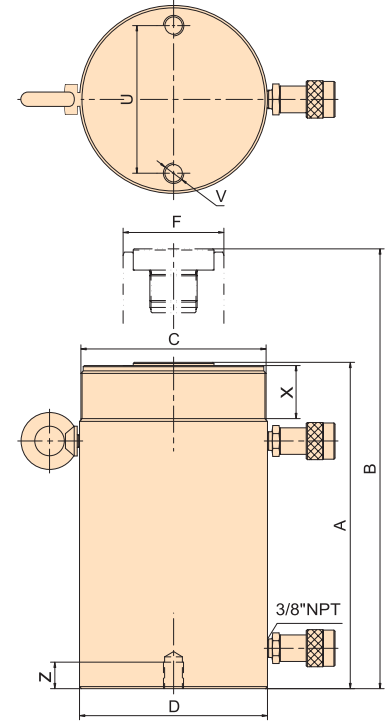

Elektrik santralinde çıkışın geçit üzerine bağlanmasında 56 adet ED-308 kullanıldı.
56 pieces of ED-308 used to flange the gate on the track in generation station.

İnmiş Durumda Yükseklik / Collapsed Height	Genişlemiş Durumda Yükseklik/ Extended Height	Sıkma Gövde/ Collar Thread	Sıkma Gövde Uzunluğu / Collar Thread Lenght	Dış Çap / Outside Diameter	Piston Mil Çapı / Piston Rod Diam.	Tutucu Cıvata Delikleri / Base Fix Holes			Ağırlık / Weight
						Çap / Diameter	Diş / Thread	Diş Derinliği/ Thread Depth	
A	B	C	X	D	F	U	V	Z	kg
mm	mm	in	mm	mm	mm	mm	in	mm	
409	663	2 1/4"-14	26	73	35	—	—	—	12
457	762	2 1/4"-14	26	73	35	—	—	—	14
387	596	3 5/16"-12	49	105	55	—	—	—	20
549	917	3 5/16"-12	49	105	55	—	—	—	31
331	487	5"-12	44	127	80	—	—	—	30
509	843	5"-12	44	127	80	—	—	—	51,9
733	1244	5"-12	44	132	80	76	1/2"-13UNC	25	69,9
347	503	5 3/4"-12	38	146	95	—	—	—	41
525	858	5 3/4"-12	38	146	95	—	—	—	67,9
357	525	6 7/8"-12	50	177	95	139	3/4"-10UNC	25	60,9
524	857	6 7/8"-12	50	177	95	139	3/4"-10UNC	25	92,9
687	1147	6 7/8"-12	50	177	95	139	3/4"-10UNC	25	116,9
196	253	8"-12	—	204	115	—	—	—	48,9
385	541	8"-12	55	204	115	158	3/4"-16UNC	28	92,9
582	915	8"-12	55	204	115	158	3/4"-16UNC	28	123,9
430	582	9 3/4"-12	—	249	135	127	1"-8UNC	25	146,8
608	938	9 3/4"-12	54	249	135	127	1"-8UNC	25	198,8
485	638	12 1/4"-12	58	312	165	158	1 1/4"-7UNC	44	199,8

ESX SERİSİ / ESX SERIES

TEK TESİRLİ YÜKSEK TONAJLI SİLİNDİRLER SINGLE ACTING, HIGH TONNAGE CYLINDERS



Soldan sağa doğru modeller / Shown from left to right
ESX-506, ESX-2002, ESX 1008

Özellikler

- ASME B-30.1 regülasyonuna uygundur. Yüksek dayanıma sahip çelik alaşım ilave emniyet sistemi sağlar.
- Montaj kolaylığı sağlayan vidalı yapı.
- Taşıma kolaylığı sağlayan mapa ve mapa yuvası.
- EAB 201 yüksek kalite, çabuk bağlantı rakorları.
- Çevre dostu boya ile korozyon dayanımı sağlanmıştır.
- Tek tesirli yük geri dönüşlü silindir.
- Eğim yatak kovanları mevcuttur.

Features

- Complies with ASME B-30.1. High grade steel cylinder is heat treated for additional strength.
- Threaded base easier to install.
- Threaded hole & rigging easier to carry.
- High flow EAB 201 quick coupler.
- Environmentally friendly painting process provides a durable corrosion resistant finish.
- Single acting, load return.
- Tilt saddle available.

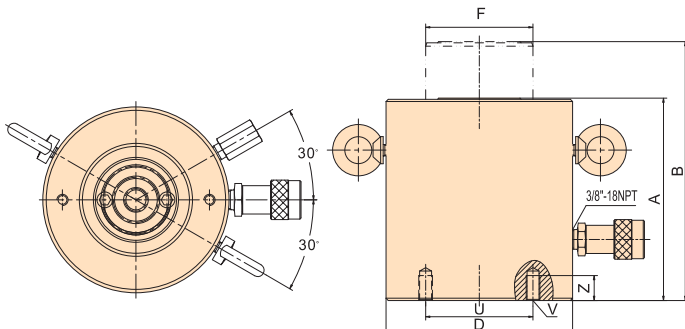

Kod no / Code No	Silindir Kapasitesi @700bar Cylinder Capacity (10.000 PSI)	Strok / Stroke	Model	Silindir Etkif Alanı / Cylinder Effective Area
				ton
91160001	50	50	ESX-502	75,4
91160002		100	ESX-504	75,4
91160003		150	ESX-506	75,4
91160004		200	ESX-508	75,4
91160005		250	ESX-5010	75,4
91160006		300	ESX-5012	75,4
91160007	100	50	ESX-1002	132,7
91160008		100	ESX-1004	132,7
91160009		150	ESX-1006	132,7
91160010		200	ESX-1008	132,7
91160011		250	ESX-10010	132,7
91160012		300	ESX-10012	132,7
91160013	150	50	ESX-1502	201
91160014		100	ESX-1504	201
91160015		150	ESX-1506	201
91160016		200	ESX-1508	201
91160017		250	ESX-15010	201
91160018		300	ESX-15012	201
91160019	200	50	ESX-2002	268,8
91160020		150	ESX-2006	268,8
91160021		300	ESX-20012	268,8
91160022	250	50	ESX-2502	363,1
91160023		150	ESX-2506	363,1
91160024		300	ESX-25012	363,1
91160025	300	50	ESX-3002	452,4
91160026		150	ESX-3006	452,4
91160027		300	ESX-30012	452,4
91160028	400	50	ESX-4002	551,5
91160029		150	ESX-4006	551,5
91160030		300	ESX-40012	551,5
91160031	500	50	ESX-5002	730,6
91160032		150	ESX-5006	730,6
91160033		300	ESX-50012	730,6
91160034	600	50	ESX-6002	855,3
91160035		150	ESX-6006	855,3
91160036		300	ESX-60012	855,3
91160037	800	50	ESX-8002	1164,2
91160038		150	ESX-8006	1164,2
91160039		300	ESX-80012	1164,2
91160040	1000	50	ESX-10002	1452,5
91160041		150	ESX-10006	1452,5
91160042		300	ESX-100012	1452,5

ESX SERİSİ / ESX SERIES



- **Yüksek basınç hortumlarını seçiniz.**
Quality pressure hoses.



- **EV-23 ile birlikte kullanılması önerilen yük taşıyıcı manuel kontrol valfi**
Use with EV-23 manually operated check valve for load holding.



- **Aşırı yüklenmeleri önlemek için sistemin çalışma basıncını kontrol etmeye yarayan göstereyi seçiniz.**
Pressure gauges available to monitor system pressure.

Yağ Kapasitesi / Oil Capacity	İnmiş Durumda Yükseklik / Collapsed Height	Genişlemiş Durumda Yükseklik / Extended Height	Dış Çap / Outside Diameter	Piston Mil Çapı / Piston Rod Diam.	Tutucu Civata Delikleri / Base Fix Holes			Ağırlık / Weight
					Civata Merk. mesafesi / Bolt Circle	Diş / Thread	Diş Derinliği / Thread Depth	
cm3	mm	mm	mm	mm	U	V	Z	kg
377,2	162	212	51	70	65	M12	22	16
754,2	212	312	51	70	65	M12	22	19
1131,4	262	412	51	70	65	M12	22	23
1508,6	312	512	51	70	65	M12	22	26
1885,8	362	612	51	70	65	M12	22	30
2262,9	412	712	51	70	65	M12	22	34
663,7	179	229	65	95	95	M12	22	28
1327,6	229	329	65	95	95	M12	22	34
1991,3	279	429	65	95	95	M12	22	40
2655,0	329	529	65	95	95	M12	22	45,9
3318,9	379	629	65	95	95	M12	22	51,9
3982,6	429	729	65	95	95	M12	22	57,9
1005,5	196	246	81	115	130	M12	22	479
2010,8	246	346	81	115	130	M12	22	56,9
3016,3	296	446	81	115	130	M12	22	65,9
4021,6	346	546	81	115	130	M12	22	74,9
5027,1	396	646	81	115	130	M12	22	84,9
6032,4	446	746	81	115	130	M12	22	93,9
1344,5	212	262	93	135	165	M12	22	67,9
4033,6	312	462	93	135	165	M12	22	92,9
8067,2	462	762	93	135	165	M12	22	128,
1816,3	235	285	108	165	190	M12	25	8
5448,7	335	485	108	165	190	M12	25	103,
10897,3	485	785	108	165	190	M12	25	9
2262,9	312	362	122	195	180	M16	30	138,
6788,8	412	562	122	195	180	M16	30	8
13577,4	562	862	122	195	180	M16	30	191,
2758,6	374	424	18	215	205	M16	30	8
8275,8	474	624	138	215	205	M16	30	176,
16551,7	624	924	138	215	205	M16	30	8
3654,4	419	469	158	250	250	M24	36	222,
10963,4	519	669	158	250	250	M24	36	7
21926,8	669	969	158	250	250	M24	36	292,
4278,3	429	479	169	265	275	M24	36	6
12834,6	529	679	169	265	275	M24	36	269,
25669,3	679	979	169	265	275	M24	36	7
5823,3	484	534	199	320	330	M24	36	329,
17469,9	584	734	199	320	330	M24	36	6
34940	734	1034	199	320	330	M24	36	420,
7262,5	564	614	221	345	375	M24	36	5
21796,3	664	814	221	345	375	M24	36	400,
43592,5	814	1114	221	345	375	M24	36	5

EDX SERİSİ / EDX SERIES

ÇİFT TESİRLİ YÜKSEK TONAJLI SİLİNDİRLER DOUBLE ACTING, HIGH TONNAGE CYLINDERS



Soldan sağa doğru modeller /
Shown from left to right
EDX-1006, EDX-1002, EDX-2006

Özellikler

- ASME B-30.1 regülasyonuna uygundur. Yüksek dayanıma sahip çelik alaşım ilave emniyet sistemi sağlar.
- Yanlışlıkla aşırı basınç uygulanmasından kaynaklanacak hasarları önlemek için silindir çıkışında emniyet valfi.
- Mapa yuvası ve mapa sayesinde taşınması kolaydır.
- EAB 201 yüksek kalite çabuk bağlantı rakorları.
- Çevre dostu boya ile korozyon dayanımı sağlanmıştır.
- Çift tesirli, hidrolik geri dönüşü.

Features

- Complies with ASME B-30.1. High grade steel cylinder is heat treated for additional strength.
- Safety valve in retraction side of cylinder helps to prevent damage in case of accidental over pressurization.
- Easy to carry with threaded hole and ring bolt.
- High flow EAB 201 quick coupler.
- Environmentally friendly painting process provides a durable corrosion resistant finish.
- Double acting, hydraulic return.

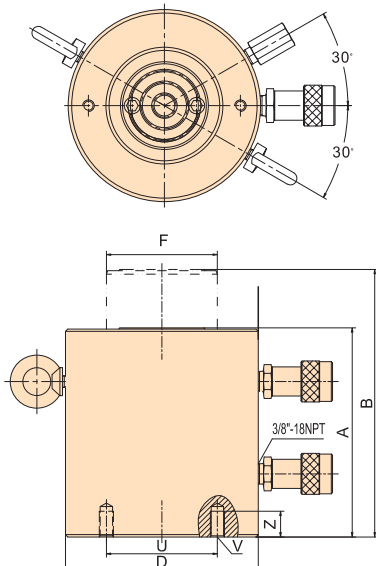

Kod no / Code No	Silindir Kapasitesi @700bar Cylinder Capacity (10.000 PSI) ton	Strok / Stroke mm	Model	Maks.Silindir Kapasitesi / Max.Cylinder Capacity		Silindir Etketif Alanı / Cylinder Effective Area	
				İleri / Advance	Geri/ Retract	İleri / Advance	Geri / Retract
				ton	ton	cm ²	cm ²
91170001	50	50	EDX-502	58	25.9	75,4	36,9
91170002		100	EDX-504	58	25.9	75,4	36,9
91170003		150	EDX-506	58	25.9	75,4	36,9
91170004		200	EDX-508	58	25.9	75,4	36,9
91170005		250	EDX-5010	58	25.9	75,4	36,9
91170006		300	EDX-5012	58	25.9	75,4	36,9
91170007	100	50	EDX-1002	102	43.3	132,7	61,9
91170008		100	EDX-1004	102	43.3	132,7	61,9
91170009		150	EDX-1006	102	43.3	132,7	61,9
91170010		200	EDX-1008	102	43.3	132,7	61,9
91170011		250	EDX-10010	102	43.3	132,7	61,9
91170012		300	EDX-10012	102	43.3	132,7	61,9
91170013	150	50	EDX-1502	154	68	201	97,2
91170014		100	EDX-1504	154	68	201	97,2
91170015		150	EDX-1506	154	68	201	97,2
91170016		200	EDX-1508	154	68	201	97,2
91170017		250	EDX-15010	154	68	201	97,2
91170018		300	EDX-15012	154	68	201	97,2
91170019	200	50	EDX-2002	203	88	268,8	125,7
91170020		150	EDX-2006	203	88	268,8	125,7
91170021		300	EDX-20012	203	88	268,8	125,7
91170022	250	50	EDX-2502	279	104.5	363,1	149,2
91170023		150	EDX-2506	279	104.5	363,1	149,2
91170024		300	EDX-25012	279	104.5	363,1	149,2
91170025	300	50	EDX-3002	348	107.6	452,4	153,7
91170026		150	EDX-3006	348	107.6	452,4	153,7
91170027		300	EDX-30012	348	107.6	452,4	153,7
91170028	400	50	EDX-4002	425	131.9	551,5	188,5
91170029		150	EDX-4006	425	131.9	551,5	188,5
91170030		300	EDX-40012	425	131.9	551,5	188,5
91170031	500	50	EDX-5002	563	167.8	730,6	239,7
91170032		150	EDX-5006	563	167.8	730,6	239,7
91170033		300	EDX-50012	563	167.8	730,6	239,7
91170034	600	50	EDX-6002	659	212.6	855,3	303,8
91170035		150	EDX-6006	659	212.6	855,3	303,8
91170036		300	EDX-60012	659	212.6	855,3	303,8
91170037	800	50	EDX-8002	896	251.9	1164,2	359,9
91170038		150	EDX-8006	896	251.9	1164,2	359,9
91170039		300	EDX-80012	896	251.9	1164,2	359,9
91170040	1000	50	EDX-10002	1118	362.2	1452,5	517,4
91170041		150	EDX-10006	1118	362.2	1452,5	517,4
91170042		300	EDX-100012	1118	362.2	1452,5	517,4

EDX SERİSİ / EDX SERIES



Yağ Kapasitesi / Oil Capacity		İnmiş Durumda Yükseklik / Collapsed Height	Genişlemiş Durumda Yükseklik/ Extended Height	Dış Çap / Outside Diameter	Piston Mil Çapı / Piston Rod Diam.	Tutucu Civata Delikleri / Base Fix Holes			Ağırlık / Weight
İleri / Advance	Geri / Retract					Civata Merk.mesafesi/ Bolt Circle	Diş / Thread	Diş Derinliği/ Thread Depth	
İleri / Advance	Geri / Retract	A	B	D	F	U	V	Z	kg
cm ³	cm ³	mm	mm	mm	mm	mm	mm	mm	kg
377,2	184,5	162	212	129	70	65	2xM12	22	16
754,2	369,2	212	312	129	70	65	2xM12	22	19
1131,4	553,7	262	412	129	70	65	2xM12	22	23
1508,6	738,3	312	512	129	70	65	2xM12	22	26
1885,8	922,8	362	612	129	70	65	2xM12	22	30
2262,9	1107,5	412	712	129	70	65	2xM12	22	34
663,7	309,6	179	229	165	95	95	2xM12	22	28
1327,6	619,3	229	329	165	95	95	2xM12	22	34
1991,3	928,9	279	429	165	95	95	2xM12	22	40
2655	1238,5	329	529	165	95	95	2xM12	22	45,9
3318,9	1548,2	379	629	165	95	95	2xM12	22	51,9
3982,6	1857,8	429	729	165	95	95	2xM12	22	57,9
1005,5	486,3	196	246	206	115	130	2xM12	22	47,9
2010,8	972,4	246	346	206	115	130	2xM12	22	56,9
3016,3	1458,6	296	446	206	115	130	2xM12	22	65,9
4021,6	1944,7	346	546	206	115	130	2xM12	22	74,9
5027,1	2431	396	646	206	115	130	2xM12	22	84,9
6032,4	2917,2	446	746	206	115	130	2xM12	22	93,9
1344,5	628,8	212	262	236	135	165	3xM12	22	67,9
4033,6	1886,3	312	462	236	135	165	3xM12	22	92,9
8067,2	3772,5	462	762	236	135	165	3xM12	22	128,8
1816,3	746,4	235	285	275	165	190	3xM12	25	103,9
5448,7	2238,9	335	485	275	165	190	3xM12	25	138,8
10897,3	4477,9	485	785	275	165	190	3xM12	25	191,8
2262,9	768,8	312	362	310	195	180	3xM16	30	176,8
6788,8	2306,5	412	562	310	195	180	3xM16	30	222,7
13577,4	4612,8	562	862	310	195	180	3xM16	30	292,6
2758,6	942,8	374	424	350	215	205	3xM16	30	269,7
8275,8	2828,7	474	624	350	215	205	3xM16	30	329,6
16551,7	5657,3	624	924	350	215	205	3xM16	30	420,5
3654,4	1199	419	469	400	250	250	3xM24	36	400,5
10963,4	3597	519	669	400	250	250	3xM24	36	479,4
21926,8	7193,9	669	969	400	250	250	3xM24	36	598,3
4278,3	1519,6	429	479	430	265	275	3xM24	36	473,4
12834,6	4558,9	529	679	430	265	275	3xM24	36	564,3
25669,3	9117,6	679	979	430	265	275	3xM24	36	700,2
5823,3	1800,2	484	534	505	320	330	3xM24	36	740,1
17469,9	5400,7	584	734	505	320	330	3xM24	36	867
34940	10801,4	734	1034	505	320	330	3xM24	36	1056,7
7265,4	2588,1	564	614	560	345	375	3xM24	36	1060,7
21796,3	7764,1	664	814	560	345	375	3xM24	36	1211,5
43592,5	15528,2	814	1114	560	345	375	3xM24	36	1437,3

ELA-SERİSİ / ELA SERIES

TEK TESİRLİ EMNİYET SOMUNLU ALÜMİNYUM SİLİNDİRLER SINGLE ACTING, ALUMINIUM LOCK NUT



ELA- 1006



Mekanik yük taşıma olanağı sağlayan emniyet somunu.
Load nut feature permits mechanical load holding

Özellikler

- Mekanik yük kaldırmaları için emniyet somunu.
- Hafiflik ve kolay taşıma olanağı.
- EAB 201 yüksek kalite çabuk bağlantı rakorları.
- Strok limitleyici olarak görev yapan taşma portu.
- Yay geri dönüşlü.
- Taşıma kolu.

Features

- Safety lock nut for mechanical load holding.
- Low weight and good portability.
- High flow EAB 201 quick coupler.
- Overflow port functions as a stroke limiter.
- Spring return.
- Features carrying handle.

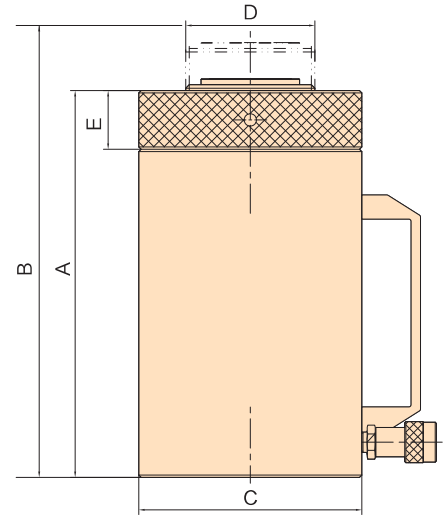

Kod no / Code No	Silindir Kapasitesi @700bar Cylinder Capacity (10.000 PSI)	Strok / Stroke	Model	Maks.Silindir Kapasitesi / Max.Cylinder Capacity	Yağ Kapasitesi / Oil Capacity	İnmiş Durumda Yükseklik / Collapsed Height	Genişleşmiş Durumda Yükseklik/ Extended Height	Dış Çap / Outside Diameter	Piston Mil Çapı / Piston Rod Diam.	Somun Kalınlığı / Nut Thickness	Ağırlık / Weight
						A	B				
	ton	mm		cm ²	cm ³	mm	mm	mm	mm	mm	kg
91138001	50	152.4	ELA-556	70.89	1098	317.5	472	138	Tr 80X4	40	12
91138002	100	152.4	ELA-1006	132.3	2098	340	498	189	Tr 110X6	50	30

ELL SERİSİ / ELL SERIES**YASSI,TEK TESİRLİ EMNİYET SOMUNLU SİLİNDİRLER
PANCAKE LOCK NUT CYLINDERS**

Soldan sağa doğru modeller / Shown from left to right
ELL-602, ELL-1002

Özellikler

- Sınırlı alanlarda kullanım kolaylığı sağlayan minimum silindir yüksekliği.
- Mekanik yük tutmayı sağlayan emniyet somunu.
- Eğimli yük yatakları.
- ASME B-30.1 regülasyonuna uygundur.
- Yüksek dayanıma sahip çelik emniyet sistemi oluşturur.
- Strok limitleyici olarak görev yapan taşma portu.
- EAB 201 yüksek kalite çabuk bağlantı rakorları.
- Çevre dostu boya ile korozyon dayanımı sağlanmıştır.

Features

- Extremely low height for use in confined spaces.
- Safety lock nut for mechanical load holding
- Tilting saddle.
- Complies with ASME B-30.1.High strength steel for durability increased safety.
- Overflow port functions as a stroke limiter.
- High flow EAB 201 quick coupler.
- Environmentally-friendly painting process provides a durable anti-corrosion finish.

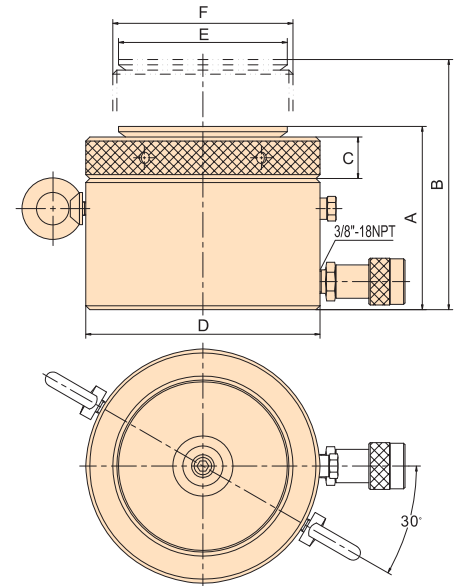

Kod no / Code No	Silindir Kapasitesi @700bar Cylinder Capacity (10.000 PSI)	Strok / Stroke	Model	Silindir Efektif Alanı / Cylinder Effective Area	Yağ Kapasitesi / Oil Capacity	Inmiş Durumda Yükseklik / Collapsed Height	Genişleşmiş Durumda Yükseklik/ Extended Height	Emniyet Somunu Yüksekliği / Lock Nut High	Dış Çap / Outside Diameter	Yatak Kovanı Çapı / Saddle Diameter	Piston Mil Çapı / Piston Rod Diam.	Ağırlık / Weight
						A	B	C	D	E	F	kg
91180001	60 (66)	50	ELL-602	86,6	433	125	175	28	140	96	Tr 104x4	14,5
91180002	100 (110)	50	ELL-1002	143,1	716	137	187	31	175	126	Tr 134,5x6	23,5
91180003	160 (176)	45	ELL-1602	227	1022	148	193	40	219	159	Tr 170x6	41,5
91180004	200 (220)	45	ELL-2002	283,5	1276	155	200	43	245	180	Tr 190x6	57
91180005	250 (275)	45	ELL-2502	363,1	1634	159	204	44	275	200	Tr 215x6	74
91180006	400 (440)	45	ELL-4002	551,5	2482	178	223	55	350	250	Tr 265x6	134
91180007	520 (572)	45	ELL-5002	730,6	3288	192	237	62	400	290	Tr 305x6	189

EL SERİSİ / EL SERIES

TEK TESİRLİ EMNİYET SOMUNLU SİLİNDİRLER SINGLE ACTING, LOCK NUT CYLINDERS



Soldan sağa doğru modeller / Shown from left to right
EL-1502 / EL-1506

Özellikler

- Mekanik yük kaldırmaları için emniyet somunu.
- EAB 201 yüksek kalite çabuk bağlantı rakorları.
- Strok limitleyici olarak görev yapan taşma portu.
- Çevre dostu boya ile korozyon dayanımı sağlanmıştır.

Features

- Safety lock nut for mechanical load holding.
- High flow EAB 201 quick coupler.
- Overflow port function as a stroke limiter.
- Environmental-friendly paintings prevent rust and corrosion ability.



1. High strength steel safety nut.
2. Movable piston head is standard accessory.
3. Hardened chrome plated sealed piston prevents wear and corrosion.
4. High strength composite bearings It protects the cylinder walls against off-center loads.
5. Industrial U type gasket prevents oil leaks.
6. Body made of high strength alloy steel It is resistant to abrasion.
7. Dust cap coupling.

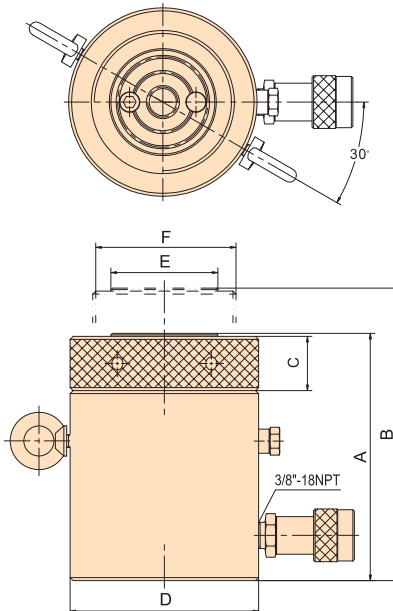

Opsiyonel Oynar Piston Başlığı

Kullanılacak Silindir Kapasitesi	Oynar Piston Başlığı Modeli
ton	
50	ST-100
100	ST-100
150	ST-200
200	ST-200
250	ST-250
300	ST-300
400	ST-400
500	ST-500
600	ST-600
800	ST-800
1000	ST-1000

EL SERİSİ / EL SERIES



- Yüksek basınç hortumlarını seçiniz.

Quality pressure hoses



- Aşırı yüklenmeleri önlemek için sistemin çalışma basıncını kontrol etmeye yarayan göstergeyi seçiniz.

Pressure gauges available to monitor system



- Opsiyonel olarak eğimli ve dişli piston başlıkları mevcuttur.

Optional tilting and threaded saddles available.

Art. No / Code No	Silindir Kapasitesi @700bar Cylinder Capacity (10.000PSI)	Strok / Stroke	Model	Silindir Efektif Alanı Cylinder Effective Area	Yağ Kapasitesi Oil Capacity	İnmiş Durumda Yükseklik Collapsed Height		Genişlemiş Durumda Yükseklik Extended Height		Emniyet Somunu Yüksekliği Lock Nu Height	Dış Çap Outside Diameter	Yatak Kovanı Çapı Saddle Diameter	Piston Mil Çapı Piston Rod Diameter	Ağırlık Weight
						A	B	C	D					
	ton	mm		cm ²	cm ³	mm	mm	mm	mm	mm	mm	mm	mm	kg
91190001	50	50	EL-502	70,9	354,6	164	214	36	125	71	Tr 95x4	15		
91190002		100	EL-504	70,9	709,3	214	3134	36	125	71	Tr 95x4	20		
91190003		150	EL-506	70,9	1063,9	264	13	36	125	71	Tr 95x4	25		
91190004		200	EL-508	70,9	1418,6	313	513	36	125	71	Tr 95x4	30		
91190005		250	EL-5010	70,9	1773,2	364	613	36	125	71	Tr 95x4	35		
91190006		300	EL-5012	70,9	2127,9	413	713	36	125	71	Tr 95x4	40		
91190007	100	50	EL-1002	132,7	663,7	187	237	44	44	71	Tr 130x6	30		
91190008		100	EL-1004	132,7	1327,6	237	336	44	44	71	Tr 130x6	47,9		
91190009		150	EL-1006	132,7	1991,3	287	436	44	44	71	Tr 130x6	55,9		
91190010		200	EL-1008	132,7	2655	336	536	44	44	71	Tr 130x6	63,9		
91190011		250	EL-10010	132,7	3318,9	286	636	44	44	71	Tr 130x6	72,9		
91190012		300	EL-10012	132,7	3982,6	436	736	44	44	71	Tr 130x6	52,9		
91190013	150	50	EL-1502	201,1	1006	206	259	44	44	129	Tr160x6	65,9		
91190014		100	EL-1504	201,1	2011,8	259	358	44	44	129	Tr160x6	65,9		
91190015		150	EL-1506	201,1	3017,8	308	458	44	44	129	Tr160x6	77,9		
91190016		200	EL-1508	201,1	4023,6	258	558	44	44	129	Tr160x6	91,9		
91190017		250	EL-15010	201,1	5029,6	408	658	44	44	129	Tr160x6	103,9		
91190018		300	EL-15012	201,1	6035,4	458	758	44	44	129	Tr160x6	116,9		
91190019	200	50	EL-2002	268,7	1344,5	243	292	50	50	129	Tr185x6	82,9		
91190020		150	EL-2006	268,7	4033,6	342	492	50	50	129	Tr185x6	117,9		
91190021		250	EL-20010	268,7	6722,7	442	692	50	50	129	Tr185x6	152,8		
91190022	250	50	EL-2502	363	1816,3	249	299	56	276	149	Tr 215x6	115,9		
91190023		150	EL-2506	363	5448,7	349	498	56	276	149	Tr 215x6	162,8		
91190024		250	EL-25010	363	9081,2	448	698	56	276	149	Tr 215x6	209,7		
91190025	300	50	EL-3002	452,3	2262,9	294	344	60	309	139	Tr 240x6	172,8		
91190026		150	EL-3006	452,3452,3	6788,8	394	544	60	309	139	Tr 240x6	232,7		
91190027		250	EL-30010	551,4	13314,5	494	744	60	309	139	Tr 240x6	292,6		
91190028	400	50	EL-4002	551,4	2758,6	335	384	70	350	159	Tr 265x6	250,7		
91190029		150	EL-4006	551,4	8275,8	434	584	70	350	159	Tr 265x6	326,6		
91190030		250	EL-40010	730	13793,1	534	784	70	350	159	Tr 265x6	402,5		
91190031	500	50	EL-5002	730	3652,4	374	424	80	399	179	Tr 305x6	366,6		
91190032		150	EL-5006	730	10957,3	474	624	80	399	179	Tr 305x6	466,4		
91190033		250	EL-50010	854,7	18262,4	574	824	80	399	179	Tr 305x6	567,3		
91190034	600	50	EL-6002	854,7	4276,1	394	444	85	429	194	Tr 330x6	446,5		
91190035		150	EL-6006	854,7	12828,6	494	644	85	429	194	Tr 330x6	562,3		
91190036		250	EL-60010	1163,3	21381	594	844	85	429	194	Tr 330x6	679,2		
91190037	800	50	EL-8002	1163,3	5820,4	454	504	100	504	224	Tr 385x6	710,1		
91190038		150	EL-8006	1163,3	17460,9	554	704	100	504	224	Tr 385x6	870		
91190039		250	EL-80010	1451,1	29101,6	654	904	100	504	224	Tr 385x6	1029,8		
91190040	1000	50	EL-10002	1451,1	12672,4	494	544	110	559	249	Tr 430x6	949,9		
91190041		150	EL-10006	1451,1	21781,2	594	744	110	559	249	Tr 430x6	1141,6		
91190042		250	EL-100010	36302,1	694	943	110	559	249	Tr 430x6	1333,4			

ESP SERİSİ / ESP SERIES

ÇEKİŞ SİLİNDİRLERİ PULLY CYLINDERS



Soldan sağa doğru modeller / Shown from left to right
ESP-606, ESP-25, ESP-46
ESP-106C, ESP-106E

Özellikler

- Yüksek dayanıklı çelik alaşım yapı.
- Aşınma ve paslanma rezistansı için krom piston çubuğu.
- Paslanma ve korozyon dayanıklılığı sağlanmıştır.
- EAB 201 yüksek kalite çabuk bağlantı rakorları.

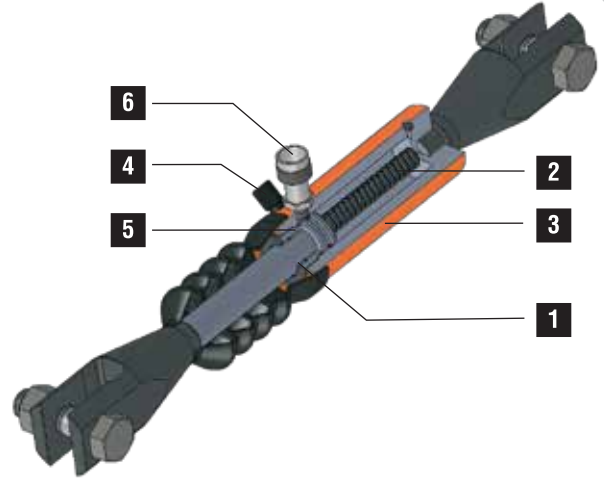

1. Endüstriyel toz keçesi kir ve pislikler karşı silindiri korur.
2. Yüksek mukavemetli geri dönüş yayı.
3. Yüksek mukavemetli alaşımli çelik gövde.
4. Dahili emniyet valfi milin aşırı açılmasını önler.
5. Yüksek mukavemetli kompozit rulman sayesinde merkezlenmemiş yüklerle karşı silindir duvarlarını korur.
6. Toz kapaklı EAB-201A dişli kaplin.

1. Industrial dust seal protects the cylinder against dirt and impurities.
2. High strength return spring.
3. High strength alloy steel body.
4. Built-in safety valve prevents the spindle from over opening.
5. Thanks to high strength composite bearing it protects the cylinder walls against off-center loads.
6. EAB-201A female coupling with dust cap.

Features

- High strength alloy steel construction.
- Chromed piston rod for wear and corrosion resistance.
- Baked enamel finish prevent rust and corrosion.
- High flow EAB 201 quick couplers.

Kod no / Code No	Silindir Kapasitesi @700bar Cylinder Capacity (10.000 PSI) ton	Strok / Stroke mm	Model	Silindir Etketif Alanı Cylinder Effective Area cm ²	Yağ Kapasitesi Oil Capacity cm ³	İnmiş Durumda Yükseklik / Collapsed Height mm	Genişlemiş Durumda Yükseklik/ Extended Height mm	Dış Çap / Outside Diameter mm	Bağlantı Delik Dış Genişliği Link Holes Width mm
						A	B	D	J
91121001	10 (11)	151	ESP-106C	14,14	214	738	587	85	119
91121002	10 (11)	151	ESP-106L	14,14	214	692	541	85	64
91121003	30 (33)	155	ESP-306	47,71	740	1240	1085	136	114
91121004	50 (55)	152	ESP-606	71,3	1084	871	719	140	130

Kod no / Code No	Silindir Kapasitesi @700bar Cylinder Capacity (10.000 PSI) ton	Strok / Stroke mm	Model	Silindir Etketif Alanı Cylinder Effective Area cm ²	Yağ Kapasitesi Oil Capacity cm ³	İnmiş Durumda Yükseklik / Collapsed Height mm	Genişlemiş Durumda Yükseklik/ Extended Height mm	Dış Çap / Outside Diameter mm	Piston Mil Çapı / Piston Rod Diam. mm	Başlık Dış çapı / Top to port mm
						A	B	D	F	H
91121005	2.5	127	ESP-25	3,9	50	391	264	50	20	45
91121006	5	140	ESP-46	7,5	105	441	301	57	30	42
91121007	10	151	ESP-106	14	214	440	289	85	35	39

ESP SERİSİ / ESP SERIES

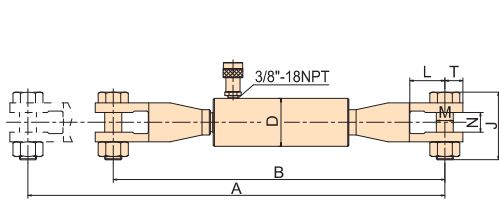

ESP106C

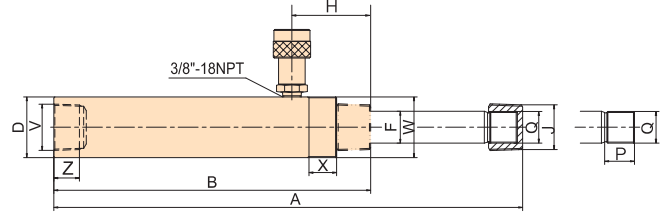

ESP25 ESP46 ESP106

ESP106L

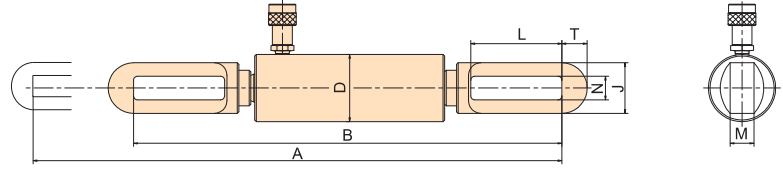

ESP606

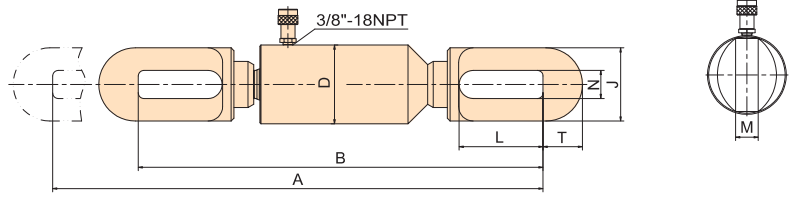

ESP306

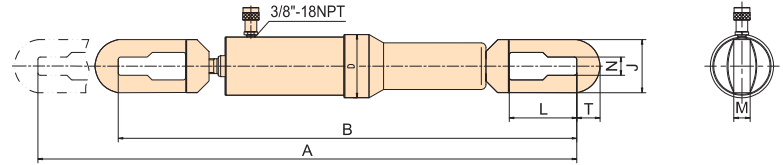

Bağlantı Delik Açılma Uzunluğu Link Holes Opening Length	Bağlantı Civata Çapı Link Bolt Diameter	Bağlantı Delik İç Genişliği Link Holes Width	Bağlantı Delik Ucu Et kalınlığı Link Holes end Width	Ağırlık / Weight	Model
L	M	N	T		
mm	mm	mm	mm	kg	
62	30	35	32	16	ESP-106C
115	22	30	32	13	ESP-106L
145	35	39	50	48	ESP-306
149	40	50	70	54	ESP-606

Yatak Kovanı Çapı Saddle Diameter	Piston Dış Uzunluğu Plunger Thread Length	Piston Dış Uzunluğu Plunger Outside Length	Taban Civata Deliği Base Fix Holes	Sıkma Bileziği Dişi Collar Thread	Sıkma Bileziği Dış Uzunluğu Collar Thread Length	Dış Uzunluğu Thread Length	Ağırlık / Weight	Model
J	P	Q	V	W	X	Z		
in	mm	mm	mm	mm	mm	mm	kg	
3/4"-14	22	11/16"-24UNEF	3/4"-14NPT	1 1/2"-16UN	27	17	1,8	ESP-25
1 1/4"-11 1/2	28	1 3/16"-16UN	1 1/4"-11 1/2NPT	2 1/4"-14UN	26	24	4,5	ESP-46
-	20	M30*2	M30X2	M85X2	25	27	9,5	ESP-106

HİDROLİK EL POMPASI SEÇİM TABLOSU

HYDRAULIC HAND PUMP SELECTION CHART/

MODEL	Kademe Stage	Akış / Flow (in ³)	Kapasite / Capacity (ton)														
			5	10	15	25	30	50	75	100	150	200	250	300	400	500	
			1" Kaldırmak için gerekli silindir stroku / Required strokes for cylinder to lift 1 inch														
EPA-10521	1. Kademe / 1st. Stage	0.22	5	10	15												
	2. Kademe / 2st. Stage	0.05	19	42	58												
EPA-10921A	1. Kademe / 1st. Stage	2.038	1	2	2	3											
	2. Kademe / 2st. Stage	0.201	6	12	16	26											
EPA-10922A	1. Kademe / 1st. Stage	2.038	1	2	2	3											
	2. Kademe / 2st. Stage	0.201	6	12	16	26											
EPA-12321A	1. Kademe / 1st. Stage	2.038	1	2	2	3	4	6	8								
	2. Kademe / 2st. Stage	0.201	6	12	16	26	31	55	81								
EPA-12322A	1. Kademe / 1st. Stage	1.59	1	2	2	3	3	6	8								
	2. Kademe / 2st. Stage	0.18	6	12	16	26	34	55	81								
EPA-14521	1. Kademe / 1st. Stage	1.59	1	1	2	3	4	8	10	13	19	26					
	2. Kademe / 2st. Stage	0.18	6	13	18	29	38	69	90	114	174	229					
EPA-14522	1. Kademe / 1st. Stage	1.59	1	1	2	3	4	8	10	13	19	26					
	2. Kademe / 2st. Stage	0.18	6	13	18	29	38	69	90	114	174	229					
EPA-17522	1. Kademe / 1st. Stage	7.63	1	1	1	1	1	2	2	3	4	5	7				
	2. Kademe / 2st. Stage	0.35	3	7	9	15	19	35	45	58	88	116	158				
EPA-17521	1. Kademe / 1st. Stage	7.63	1	1	1	1	1	2	2	3	4	5	7				
	2. Kademe / 2st. Stage	0.35	3	7	9	15	19	35	45	58	88	116	158				

HAVALI HİDROLİK EL POMPASI SEÇİM TABLOSU

AIR HYDRAULIC HAND PUMP SELECTION CHART

MODEL	Tek Kademe Single Stage	Akış / Flow (in ³)	Kapasite / Capacity (ton)														
			5	10	15	25	30	50	75	100	150	200	250	300	400	500	
			1" Kaldırmak için gerekli zaman (sn) / Required time (seconds) for cylinder to lift 1 inch														
EPC-001	Alçak Basınç / Low Pressure	0.81	1.30	2.90	3.90	6.40	8.30	15.00	19.50	25.60							
	Yüksek Basınç / High Pressure	0.12	8.70	19.00	26.30	42.50	55.00	100.00	130.00	166.00							
EPC-002	Alçak Basınç / Low Pressure	0.81	1.30	2.90	3.90	6.40	8.30	15.00	19.50								
	Yüksek Basınç / High Pressure	0.12	8.70	19.00	26.30	42.50	55.00	100.00	130.00								
EPC-003	Alçak Basınç / Low Pressure	0.81	1.30	2.90	3.90	6.40	8.30	15.00	19.50	25.60							
	Yüksek Basınç / High Pressure	0.12	8.70	19.00	26.30	42.50	55.00	100.00	130.00	166.00							
EPC-004	Alçak Basınç / Low Pressure	0.81	1.30	2.90	3.90	6.40	8.30	15.00	19.50	25.60	38.00						
	Yüksek Basınç / High Pressure	0.12	8.70	19.00	26.30	42.50	55.00	100.00	130.00	166.00	252.50						
EPC-008	Alçak Basınç / Low Pressure	0.81	1.30	2.90	3.90	6.40	8.30	15.00	19.50								
	Yüksek Basınç / High Pressure	0.12	8.70	19.00	26.30	42.50	55.00	100.00	130.00								
EPC-009	Alçak Basınç / Low Pressure	0.81	1.30	2.90	3.90	6.40	8.30	15.00	19.50	25.60	38.00						
	Yüksek Basınç / High Pressure	0.12	8.70	19.00	26.30	42.50	55.00	100.00	130.00	166.00	252.50						
EPC-010	Alçak Basınç / Low Pressure	0.81	1.30	2.90	3.90	6.40	8.30	15.00	19.50								
	Yüksek Basınç / High Pressure	0.12	8.70	19.00	26.30	42.50	55.00	100.00	130.00								

HİDROLİK ELEKTRİK POMPASI SEÇİM TABLOSU

HYDRAULIC ELECTRIC PUMP SELECTION CHART

MODEL	Tek Kademe Single Stage	Akış / Flow (in ³)	Kapasite / Capacity (ton)														
			5	10	15	25	30	50	75	100	150	200	250	300	400	500	
			1" Kaldırmak için gerekli zaman (sn) / Required time (seconds) for cylinder to lift 1 inch														
EPB-3B+	1. Kademe / 1st. Stage	4.00	0.3	0.6	0.8	1.3	1.7	2.8	4.0	5.1							
	2. Kademe / 2st. Stage	0.27	4.1	8.4	12.2	19.3	25.5	41.2	60.3	76.8							
EPB-6B+	1. Kademe / 1st. Stage	10.17	0.1	0.2	0.3	0.5	0.7	1.1	1.6	2.0	3.0	4.1					
	2. Kademe / 2st. Stage	0.65	1.7	3.5	5.0	7.9	10.5	16.9	24.8	31.5	47.5	63.4					
EPB-10B+	1. Kademe / 1st. Stage	10.17	0.1	0.2	0.3	0.5	0.7	1.1	1.6	2.0	3.0	4.1	5.5				
	2. Kademe / 2st. Stage	1.00	1.1	2.3	3.3	5.2	6.8	11.0	16.1	20.5	30.9	41.2	56.2				
EPB-20B+	1. Kademe / 1st. Stage	10.17	0.1	0.2	0.3	0.5	0.7	1.1	1.6	2.0	3.0	4.1	5.5	7.0	8.7	11.1	
	2. Kademe / 2st. Stage	1.67	0.7	1.3	2.0	3.1	4.1	6.6	9.6	12.3	18.5	24.7	33.7	42.3	53.1	67.8	

 Tavsiye edilen uygulama / Recommended application

 Seçici kullanım / Selective use

 Tavsiye edilmez / Not recommended

EPA SERİSİ / EPA SERIES

EL POMPALARI / HAND PUMPS



EPA-10521



EPA-10921C



EPA-10921A



EPA-12321A



EPA-12322A

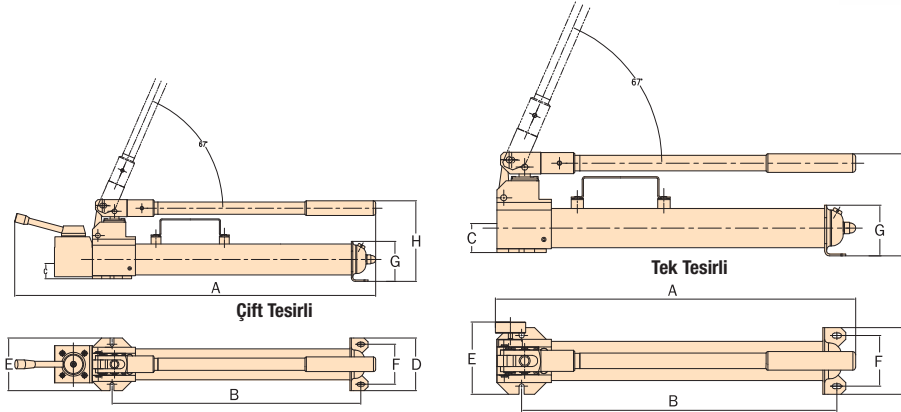

Özellikler

- Ağır çevresel şartlarda kullanıma uygun yüksek dayanıma sahip çelik alaşım yapı.
- Taşınması kolay, yer kaplamayan dizayn.
- Kullanıcı dostu tasarım.
- Yapı üzerinde mevcut emniyet valfi.
- Silindir ve diğer ekipmanlara güç sağlayıcıdır.

Features

- High strength steel alloy, engineered in use for extreme environment.
- Compact easy to carry.
- User friendly design.
- Built-in safety valve.
- Used for various cylinders and tools.

Kullanılan Silindir Tipi / Used with cylinder	Kod no / Code No	Model	Hız Speed	Kullanılabilir Yağ Kapasitesi Usable Oil Capacity	Basınç Oranları Pressure Rating		Yağ Çıktısı / Strok Oil Output Per Stroke		Kol Kuvveti Handle force	Diş Yağ Çıktısı Output Oil Thread	Ağırlık / Weight
					Aşama 1 Stage 1	Aşama 2 Stage 2	Aşama 1 Stage 1	Aşama 2 Stage 2			
					cm3	psi	psi	cm3			
Tek Tesirli / Single Acting	91123001	EPA 10521*	Çift / Double	330	200	10,000	7,9	0,8	35	3/8 - 18NPT	2.2
	91123003	EPA 10921A	Çift / Double	900	360	10,000	33,5	3,3	49	3/8 - 18NPT	7.3
	91123005	EPA 12321A	Çift / Double	2300	360	10,000	33,5	3,3	49	3/8 - 18NPT	10,1
	91123011	EPA 10921C	Çift / Double	330	360	10,000	33,5	3,3	49	3/8 - 18NPT	13
Çift Tesirli / Double Acting	91123007	EPA 10922A	Çift / Double	900	360	10,000	33,5	3,3	49	3/8 - 18NPT	8,8
	91123009	EPA 12322A	Çift / Double	2300	360	10,000	33,5	3,3	49	3/8 - 18NPT	11.6

*EPA 10521: Alüminyum el pompası üzerinde vana bloğu ve alüminyum haznesi bulunur.

* EPA 10521: There is a valve block and aluminum chamber on the aluminum hand pump.

Kod no / Code No	Model	A	B	C	D	E	F	G	H
		mm	mm	mm	mm	mm	mm	mm	mm
91123001	EPA 10521	374	290	/	80	109	67	/	142
91123003	EPA 10921A	581	505	47	108	130	82	82	165
91123005	EPA 12321A	738	507	47	125	137	/	82	161
91123007	EPA 10922A	581	505	29	108	107	82	82	165
91123009	EPA 12322A	738	507	29	125	107	/	82	161115
91123011	EPA 10921C	525	488	47	108	130	90	80	8

EPA SERİSİ / EPA SERIES

EL POMPASI / HAND PUMPS



EPA - 12322A (17521)



EPA - 10922A (14521)



EPA-17522



EPA-14522

Özellikler

- Ağır çevresel şartlarda kullanıma uygun yüksek dayanıma sahip çelik alaşım yapı.
- Kullanıcı dostu tasarım.
- Yapı üzerinde mevcut emniyet valfi.

Features

- High strength steel alloy, engineered in use for extreme environment.
- User friendly design.
- Built-in safety valve.

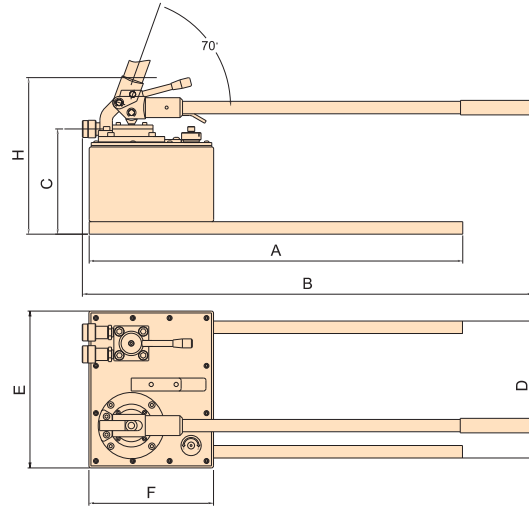

Kod no / Code No	Kullanılan Silindir / Used With Cylinder	Model	Hız Speed	Kullanılabilir Yağ Hacmi Usable Oil Volume	Basınç Oranları Pressure Rating		Yağ Çıktısı / Strok Oil Output Per Stroke		Kol Kuvveti Handle force	Dış Yağ Çıktısı Output Oil Thread	Ağırlık / Weight
					Aşama 1 1 Stage	Aşama 2 2 Stage	Aşama 1 1 Stage	Aşama 2 2 Stage			
					cm3	psi	psi	cm3			
91123012	Tek Tesirli / Single Acting	EPA-10922A (14521)	Çift/Double	4500	260	10.000	26.1	3	50.8	3/8 - 18NPT	22.5
91123014		EPA-12322A (17521)	Çift/Double	7500	260	10.000	124.6	5,7	50.8	3/8 - 18NPT	30
91123013	Çift Tesirli / Double Acting	EPA - 14522	Çift/Double	4500	260	10.000	26.1	3	50.8	3/8 - 18NPT	22.5
91123015		EPA - 17522	Çift/Double	7500	260	10.000	124.6	5,7	50.8	3/8 - 18NPT	30

Model	A	B	C	D	E	F	H
	mm	mm	mm	mm	mm	mm	mm
EPA-10922A (14521)	579	607	163	274	315	249	267
EPA-12322A (17521)	800	904	211	274	315	249	315
EPA - 14522	579	607	163	274	315	249	267
EPA - 17522	800	904	211	274	315	249	315

EPA SERİSİ / EPA SERIES

ULTRA YÜKSEK BASINÇ EL POMPASI

ULTRA HIGH PRESSURE HAND PUMP

EPA-21621

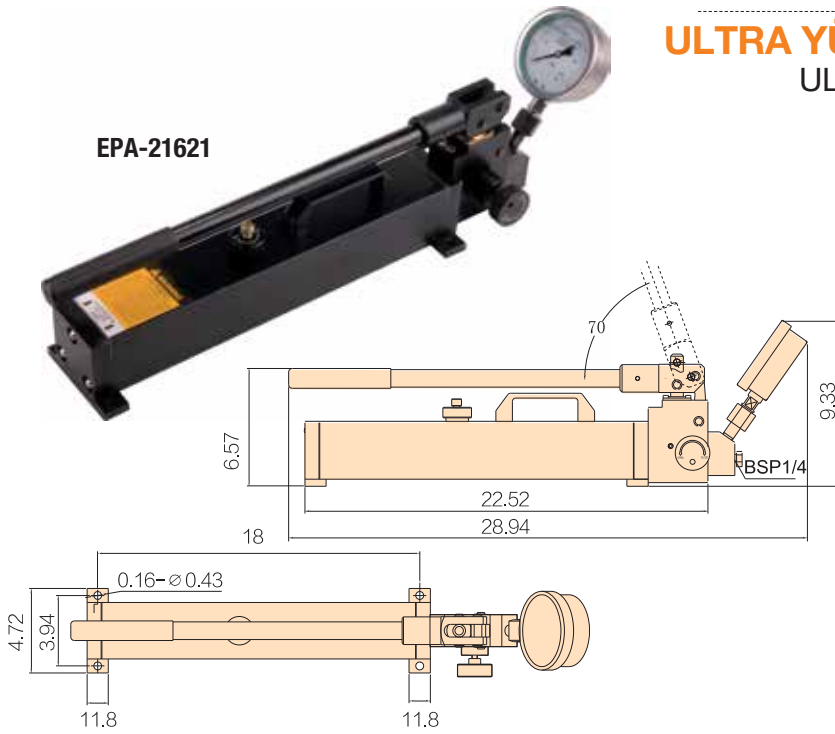

Özellikler

- Ağır çevresel şartlarda kullanıma elverişli yüksek dayanıma sahip tasarım.
- Çift hızlı pompa.
- Aşırı yük koruması için dahili valf.
- Ergonomik kol tasarımı çalışma esnasında minimum efor sarfedilmesini sağlar.

Features

- Convenient high strength design, engineered for use in extreme environments.
- Dual speed pump.
- Built-in safety valve for overload protection
- Unique handle designed require less effort, saving you time and energy.

Ultra Yüksek Basınçlı Pompa / Ultra High Pressue Hand Pump

Kod no / Code No	Kullanılan Silindir / Used With Cylinder	Model	Hız Speed	Kullanılabilir Yağ Hacmi Usable Oil Volume	Basınç Oranları Pressure Rating		Yağ Çıktısı / Strok Oil Output Per Stroke		Kol Kuvveti Handle force	Diş Yağ Çıktısı Output Oil Thread	Ağırlık / Weight
					Aşama 1 1 Stage	Aşama 2 2 Stage	Aşama 1 1 Stage	Aşama 2 2 Stage			
					cm3	psi	psi	cm3			
91123016	Tek Tesirli Single Acting	EPA - 21621	Çift/Double	1600	290	20.000	26,1	0,8	20	1/4 BSP	9.5

Ultra Yüksek Basınçlı Hortum / Ultra High Pressure Hydraulic Hoses

Kod no / Code No	Hortum Malzemesi Hose Material	Model	İç Çap Internal Dia.	Çalışma Basıncı Work Pressure	Patlama Basıncı Burst Pressure	Diş Tread	Uzunluk Length
			in	psi	psi		
91133011	Termo Plastik Thermo Plastic	EH-7103	1/8"	20.000	65.000	1/4 BSP	0.9
91133008	Termo Plastik Thermo Plastic	EH-7106	1/8"	20.000	65.000	1/4 BSP	1.8
91133009	Termo Plastik Thermo Plastic	EH-7110	1/8"	20.000	65.000	1/4 BSP	3
91133010	Termo Plastik Thermo Plastic	EH-7120	1/8"	20.000	65.000	1/4 BSP	6



Ultra Yüksek Basınçlı Kaplin / Ultra High Pressure Hydraulic Couplers

Kod no / Code No	Tip / Type	Model	Erkek Kaplin Male Couplers	Dişi Kaplin Female Couplers	Maksimum Basınç Max. Pressure	Diş Tread
91132004 - Dişi 91132008 - Erkek	Ultra Yüksek Akış	EAB - 204	EAB 204B	EAB 204A	20.000	1/4 BSP



EPB SERİSİ / EPB SERIES

ELEKTRİKLİ POMPA / ELECTRIC PUMPS



EPB -171A (3B5P5A)

EPB-175A (3B1P5A)

Yağ Hazne Kapasitesi / Reservoir Capacity

2.0 / 5.0 / 10.0 Litre

Akış / Flow at Rated Pressure

0.3 / 0.6 l/dk

Motor

0.75 / 1.0 hp

Özellikler

- Pek çok sektörel uygulamalar için kullanılır.
- Yüksek akış oranı 0.3 lt/ dk ve 0.6 lt/ dk ulaşır.
- 3m 24V uzaktan kumanda veya selenoid kumanda.
- 0.75 hp ve 1.0 hp motor
- Tam yük altında çalışır.
- Taşıma kolu ile yüksek dayanıma sahip gövde.

EPB-3B Serisi

Art.No Code No	Model	Kullandığı Silindir Used With Cylinder	Tanım / Description	Çıkış Akış Oranı Output Flow Rate (lt/ dk)	
				1. Kademe 1. Stage	2. Kademe 2. Stage
91124001	EPB 171A (3B1P5E)	Tek Tesirli Single Acting	5 lt yağ kapasitesi, 3W/ 2P, manuel vana, kumanda swici, 380 W 1.3 Gallon usable oil reservoir, 3W/2P, manuel valve, pendant switch, 380V	3.9	0.3
91124012	EPB 1710A (3B10P2E)	Dump	5 lt yağ kapasitesi, 4W/ 3P dump vanalı. Kaldırma amaçlı değil, kıvrırma, delme, pres işlemleri için uygundur. / 1.3 Gallon usable oil reservoir, 4W/3P with dump valve. Suited for crimping, punching, pressing, not for lifting.	3.9	0.3
91124005	EPB 175A (3B5P5E)	Çift Tesirli Double Acting	2 lt yağ kapasitesi, 2W/ 2P manuel vana, kumanda swici, 380 W 0.53 Gallon usable oil reservoir, 2W/2P manuel valve, pendant switch, 380V	3.9	0.3

Valf Valve	Valf Tipi Valve Type	Valf Fonksiyonu Valve Function	Kontrol Anahtarı Control Type	Motor	Kullanılabilir Yağ Kapasitesi Usable Oil Capacity		Ağırlık Weight
					lt	cm ³	
EV 42H2	2W, 2P	İleri- Geri ** Advance-Return	Kablolu Kumanda (3m) Cable Control (3m)	380 V, 50Hz	5	4930	25.4
EV 62H3	2W, 2P	İleri- Geri ** Advance-Return	Kablolu Kumanda (3m) Cable Control (3m)	380 V, 50Hz	2	2010	15.8
EV 43M4	Auto/ Dump 4W, 3P	İleri- Tutma-Geri Advance-Hold- Return	Kablolu Kumanda (3m) Cable Control (3m)	380 V, 50Hz	5	4930	25.4

EPB-6B Serisi

Art.No Code No	Model	Kullandığı Silindir Used With Cylinder	Tanım / Description	Çıkış Akış Oranı Output Flow Rate (lt/ dk)	
				1. Kademe 1st. Stage	1. Kademe 1st. Stage
91124013	EPB 508A (6B8P10E)	Tek Tesirli Single Acting	10 lt yağ kapasitesi, 3W/ 3P selenoid vana, kumanda swici, 380 W 2.6 Gallon usable oil reservoir, 4W/2P solenoid valve, pendant switch, 380V	9.8	0.6
91124014	EPB 502SA (6B2D10E)	Tek Tesirli Single Acting	10 lt yağ kapasitesi, 2W/ 2P manuel vana, kumanda swici, 380 W 2.6 Gallon usable oil reservoir, 3W/3P manuel valve, pendant switch, 380V	9.8	0.6
91124015	EPB 505A (6B5P10E)	Çift Tesirli Double Acting	10 lt yağ kapasitesi, 4W/ 3P manuel vana, kumanda swici, 380 W 2.6 Gallon usable oil reservoir, 4W/3P manuel valve, pendant switch, 380V	9.8	0.6
91124016	EPB 504SA (6B4D10E)	Çift Tesirli Double Acting	10 lt yağ kapasitesi, 4W/ 2P selenoid vana, kumanda swici, 380 W 2.6 Gallon usable oil reservoir, 2W/2P solenoid valve, pendant switch 380V	9.8	0.6

Valf Valve	Valf Tipi Valve Type	Valf Fonksiyonu Valve Function	Kontrol Anahtarı Control Type	Motor	Kullanılabilir Yağ Kapasitesi Usable Oil Capacity		Ağırlık Weight
					lt	cm ³	
EV 43M3	3W, 3P	İleri- Tutma-Geri Advance-Hold- Return	Kablolu Kumanda (3m) Cable Control (3m)	380 V, 50Hz	10	9858	34
EV 52H2	2W, 2P	İleri- Geri ** Advance-Return	Kablolu Kumanda (3m) Cable Control (3m)	380 V, 50Hz	10	9858	34
EV 43M4	4W, 3P	İleri- Tutma-Geri Advance-Hold- Return	Kablolu Kumanda (3m) Cable Control (3m)	380 V, 50Hz	10	9858	34
EV 52H4	4W, 2P	İleri- Geri ** Advance-Return	Kablolu Kumanda (3m) Cable Control (3m)	380 V, 50Hz	10	9858	34

**Motor kapalı konumda iken "İleri" pozisyonu basınç tutar.

** "Forward" position keeps pressure while the engine is turned off.

EPB SERİSİ / EPB SERIES

ELEKTRİKLİ POMPA / ELECTRIC PUMPS

Yağ Hazne Kapasitesi / Reservoir Capacity

10 / 20 Litre

Akış / Flow at Rated Pressure

0.96 / 1.92 l/dk

Motor

2.0/ 3.0 hp

Features

- Covers most applications in the industry.
- High flow rate reaches 0.3 lt/ min and 0.6 lt/ min
- 3m 24 V remote control or solenoid control for operator safety.
- 0.75 hp and 1.0 hp motor.
- Starts under full load.
- High strengt frame with handle for maximum portability.



EPB- 10B4D10A

EPB- 10B5P10A

EPB-10B Serisi

Art.No Code No	Model	Kullanıldığı Silindir Used With Cylinder	Tanım / Description	Çıkış Akış Oranı Output Flow Rate (lt/ dk)	
				1. Kademe 1. Stage	2. Kademe 2. Stage
91124017	EPB 10B8P10E	Tek Tesirli Single Acting	10 lt yağ kapasitesi, 3W/ 3P solenoid vana, kumanda swici, 380 W 2.6 Gallon usable oil reservoir, 4W/2P solenoid valve, pendant switch, 380W	9.8	0.96
91124018	EPB 10B2D10E	Tek Tesirli Single Acting	10 lt yağ kapasitesi, 2W/ 2P manuel vana, kumanda swici, 380 W 2.6 Gallon usable oil reservoir, 3W/3P manuel valve, pendant switch, 380W	9.8	0.96
91124007	EPB 10B5P10E	Çift Tesirli Double Acting	10 lt yağ kapasitesi, 4W/ 3P manuel vana, kumanda swici, 380 W 2.6 Gallon usable oil reservoir, 4W/3P manuel valve, pendant switch, 380W	9.8	0.96
91124008	EPB 10B4D10E	Çift Tesirli Double Acting	10 lt yağ kapasitesi, 4W/ 2P solenoid vana, kumanda swici, 380 W 2.6 Gallon usable oil reservoir, 2W/2P solenoid valve, pendant switch 380W	9.8	0.96

Valf	Valf Tipi	Valf Fonksiyonu	Kontrol Anahtar	Motor	Kullanılabilir Yağ Kapasitesi		Ağırlık
					lt	cm ³	
EV 43M3	3W, 3P	İleri- Geri ** Advance-Return	Kablolu Kumanda (3m) Cable Control (3m)	380 V, 50Hz	10	9858	45
EV 52H2	2W, 2P	İleri- Geri ** Advance-Return	Kablolu Kumanda (3m) Cable Control (3m)	380 V, 50Hz	10	9858	45
EV 43M4	4W, 3P	İleri- Tutma-Geri Advance-Hold- Return	Kablolu Kumanda (3m) Cable Control (3m)	380 V, 50Hz	10	9858	45
EV 52H4	4W, 2P	İleri- Geri ** Advance-Return	Kablolu Kumanda (3m) Cable Control (3m)	380 V, 50Hz	10	9858	45

EPB-20 Serisi

Art.No Code No	Model	Kullanıldığı Silindir Used With Cylinder	Tanım / Description	Çıkış Akış Oranı Output Flow Rate (lt/ dk)	
				1. Kademe 1. Stage	2. Kademe 2. Stage
91124019	EPB 20B8M20E	Tek Tesirli Single Acting	20 lt yağ kapasitesi, 3W/ 3P manuel vana, kumanda swici, 380 W	9.8	1.92
91124020	EPB 20M5M20E	Çift Tesirli Double Acting	20 lt yağ kapasitesi, 2W/ 2P solenoid vana, kumanda swici, 380 W	9.8	1.92

Valf Valve	Valf Tipi Valve Type	Valf Fonksiyonu Valve Fontion	Kontrol Anahtar Control Type	Motor	Kullanılabilir Yağ Kapasitesi Usable Oil Capacity		Ağırlık Weight
					lt	cm ³	
EV 43M3	3W, 3P	İleri- Tutma-Geri Advance-Hold- Return	Manuel Kontrol (3m) Manuel Control (3m)	380 V, 50Hz	20	20000	55
EV 43M4	4W, 3P	İleri- Tutma-Geri Advance-Hold- Return	Manuel Kontrol (3m) Manuel Control (3m)	380 V, 50Hz	20	20000	55

**Motor kapalı konumda iken "İleri" pozisyonu basınç tutar.

** "Forward" position keeps pressure while the engine is turned off.

EPB SERİSİ / EPB SERIES

YÜKSEK KAPASİTELİ YAĞ TANKLARI / LARGE OIL RESERVOIR KITS

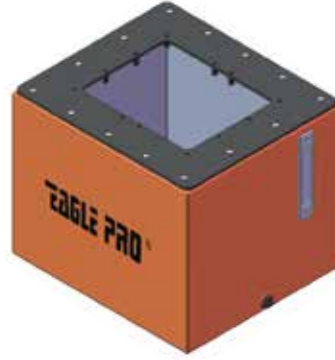
**EPB-5020LRK****EPB-5040LRK**

Art.No Code No:	Hazne Modeli Tank Model	Elektrik Pompa Modeli Electric Pump Model	Standart Yağ Kapasitesi Standart Oil Capacity	Tanım / Description	Malzeme Material
91142001	EPB 1708LRK	EPB 17 SERİSİ	5 L	EPB - 17 Serisine uygun 8 lt yağ kapasiteli tank 2.1 Gallon/8L Reservoir kits for EPB-17 Seris	Alüminyum Aluminium
91142002	EPB 5020LRK	EPB 50 SERİSİ	8 L	EPB - 50 Serisine uygun 20 lt yağ kapasiteli tank 5.3 Gallon/20L Reservoir kits for EPB-50 Seris	Alüminyum Aluminium
91142003	EPB 5040LRK	EPB 50 SERİSİ	8 L	EPB - 50 Serisine uygun 40 lt yağ kapasiteli tank 10 Gallon/40L Reservoir kits for EPB-50 Seris	Çelik Steel
91142004	EPB 10040LRK	EPB 100 SERİSİ	20 L	EPB - 100 Serisine uygun 40 lt yağ kapasiteli tank 10 Gallon/40L Reservoir kits for EPB-100 Seris	Çelik Steel
91142005	EPB 10080LRK	EPB 100 SERİSİ	20 L	EPB - 100 Serisine uygun 80 lt yağ kapasiteli tank 20 Gallon/80L Reservoir kits for EPB-100 Seris	Çelik Steel

ELEKTRİK POMPASI KORUYUCU KAFES / ROLL CAGES

**EPB-5040RC****EPB-5020RC**

Art.No Code No:	Hazne Modeli Tank Model	Elektrik Pompa Modeli Electric Pump Model	Standart Yağ Kapasitesi Standart Oil Capacity	Tanım / Description	Malzeme Material
91143001	EPB 175 RC	EPB 17 SERİSİ	5 L	EPB - 17 Serisine uygun 5 lt yağ kapasiteli tank 1.3 Gallon/5L Reservoir kits for EPB-17 Seris	Çelik Steel
91143002	EPB 178 RC	EPB 17 SERİSİ	5 L	EPB - 17 Serisine uygun 5 lt yağ kapasiteli tank 1.3 Gallon/5L Reservoir kits for EPB-17 Seris	Çelik Steel
91143003	EPB 508 RC	EPB 50 SERİSİ	8 L	EPB - 50 Serisine uygun 8 lt yağ kapasiteli tank 2.1 Gallon/8L Reservoir kits for EPB-50 Seris	Çelik Steel
91143004	EPB 5020 RC	EPB 50 SERİSİ	8 L	EPB - 50 Serisine uygun 20 lt yağ kapasiteli tank 5.3 Gallon/20L Reservoir kits for EPB-50 Seris	Çelik Steel
91143005	EPB 5040 RC	EPB 50 SERİSİ	8 L	EPB - 50 Serisine uygun 40 lt yağ kapasiteli tank 10 Gallon/40L Reservoir kits for EPB-50 Seris	Çelik Steel
91143006	EPB 10020 RC	EPB 100 SERİSİ	20 L	EPB - 100 Serisine uygun 20 lt yağ kapasiteli tank 5.3 Gallon/20L Reservoir kits for EPB-100 Seris	Çelik Steel
91143007	EPB 10040 RC	EPB 100 SERİSİ	20 L	EPB - 100 Serisine uygun 40 lt yağ kapasiteli tank 10 Gallon/40L Reservoir kits for EPB-100 Seris	Çelik Steel
91143008	EPB 10080 RC	EPB 100 SERİSİ	20 L	EPB - 100 Serisine uygun 80 lt yağ kapasiteli tank 20 Gallon/80L Reservoir kits for EPB-100 Seris	Çelik Steel

EPC SERİSİ / EPC SERIES

HAVALI TAHRİKLİ POMPALAR / AIR HYDRAULIC PUMPS

Özellikler

- Faklı hidrolik silindirler, presler ve diğer hidrolik araçlarla kullanım imkanı.
- Çalışma hava basıncı 0.6-1.0 Mpa.
- 10000 psi ye kadar çalışma basıncı.
- Giriş portu dişi 1/4-18 NPT ve çıkış portu dişi 3/8-18 NPT".
- Aşırı yüklenmeyi önleyici dahili yük seviyelendirici.
- Hava motorunun sessiz pompalamasını sağlayan hava egsoz susturucusu.
- Dış kirlilikle oluşabilecek hasar riskini azaltan hava ve yağ filtresi.
- Çeşitli ebatlarda, plastik, alüminyum ve çelik malzemeden yağ tankı seçeneği.

Features

- Can be used with a variety of hydraulic cylinders, presses or other hydraulic tools.
- Operating air pressure between 0.6 -1.0 MPa.
- Provides up to 10000 PSI of hydraulic pressure.
- Input port thread 1/4-18 NPT and output 3/8-18 NPT.
- Internal load limiting device avoids overload.
- Air exhaust muffler for quiet operation.
- Pumps feature both air and oil filters to reduce risk of damage from environmental contaminants.
- Various capacities available with plastic, aluminum or steel housings.



- Havlandırma valfi ile daha iyi kullanım ve koruma.

Knob style vent valve provides better operation and protection



Kod no Code No	Model	Basınç Oranı Pressure Rating	Hava Kaynak Basıncı Air Source Pressure	Efektif Yağ Kapasitesi Effective Oil Capacity	Akış / Flow/ (cm ³ /min) (cm ³ dk)		Boyutlar Dimensions (mm)			Yağ Tank Metaryali Oil Tank Material	Çalıştırma şekli Operational Manner	Ağırlık Weight
		psi	psi	cm ³	Yüksüz No Load	Yüklü Load	L	W	H			kg
91125001	EPC 001	10000	90-145	2294	49.5	7.6	312	170	191	Plastik Engineering Plastic	Ayak Pedallı Foot Pedal	49
91125002	EPC 002	10000	90-145	1606	49.5	7.6	262	135	185	Alüminyum Alaşım/ Alloy Aluminum	Ayak Pedallı Foot Pedal	12
91125003	EPC 003	10000	90-145	4506	49.5	7.6	317	178	191	Çelik / Steel	Ayak Pedallı Foot Pedal	8.6
91125004	EPC 004	10000	90-145	7243	49.5	7.6	279	223	254	Çelik / Steel	Ayak Pedallı Foot Pedal	12.6
91125008	EPC 008	10000	90-145	1606	49.5	7.6	262	135	185	Alüminyum Alaşım Alloy Aluminum	Uzaktan Kumanda Remote Control	16.3
91125009	EPC 009	10000	90-145	7243	49.5	7.6	262	135	185	Çelik / Steel	Uzaktan Kumanda Remote Control	11.3
91125010	EPC 010	10000	90-145	1606	49.5	7.6	262	135	185	Plastik Engineering Plastic	Ayak Pedallı Foot Pedal	8.6

EH SERİSİ / EH SERIES

YÜKSEK BASINÇ HORTUMLARI HIGH PRESSURE HOSES







Art.No Code No	Model	Hortum Malzemesi Hose Material	İç Çap Internal Dia.	Çalışma Basıncı Working Pressure	Patlama Basıncı Burst Pressure	Diş Thread	Uzunluk / Length	
							(ft)	(m)
91133011	EH 7103	Termo P.	1/8"	20.000 psi	65.000 psi	1/4 BSP	3	0,9
91133008	EH 7106	Termo P.	1/8"	20.000 psi	65.000 psi	1/4 BSP	6	1,8
91133009	EH 7110	Termo P.	1/8"	20.000 psi	65.000 psi	1/4 BSP	10	3
91133010	EH 7120	Termo P.	1/8"	20.000 psi	65.000 psi	1/4 BSP	20	6
91133001	EH 7203	Termo P.	1/4"	10.000 psi	40.000 psi	3/8 NPT	3	0,9
91133002	EH 7206	Termo P.	1/4"	10.000 psi	40.000 psi	3/8 NPT	6	1,8
91133003	EH 7210	Termo P.	1/4"	10.000 psi	40.000 psi	3/8 NPT	10	3
91133004	EH 7220	Termo P.	1/4"	10.000 psi	40.000 psi	3/8 NPT	20	6
91133025	EH 8203	Lastik	1/4"	10.000 psi	20.000 psi	3/8 NPT	3	0,9
91133026	EH 8206	Lastik	1/4"	10.000 psi	20.000 psi	3/8 NPT	6	1,8
91133027	EH 8206T	Lastik	1/4"	10.000 psi	20.000 psi	1/4 NPT	6	1,8
91133028	EH 8210	Lastik	1/4"	10.000 psi	20.000 psi	3/8 NPT	10	3
91133029	EH 8220	Lastik	1/4"	10.000 psi	20.000 psi	3/8 NPT	20	6
91133030	EH 8303	Lastik	3/8"	10.000 psi	20.000 psi	3/8 NPT	3	0,9
91133031	EH 8306	Lastik	3/8"	10.000 psi	20.000 psi	3/8 NPT	6	1,8
91133032	EH 8310	Lastik	3/8"	10.000 psi	20.000 psi	3/8 NPT	10	3
91133033	EH 8320	Lastik	3/8"	10.000 psi	20.000 psi	3/8 NPT	20	6

EAB SERİSİ / EAB SERIES

ÇABUK BAĞLANTI RAKORLARI QUICK COUPLERS

Yüksek kaliteli çabuk bağlantı rakorları.
High quality quick couplers.

P&P rakorlar, diş tipleri, küresel vanalı, pim vanalı tipleri mevcuttur.
Female(male)coupler in P&P, thread types, with ball valve, pin valve available.

Model	Max.Basınç Max. Pressure (psi)	Tip Type	Diş Thread	Art. No Art. No	Dişi Bağlantı Female Couplers	Art. No	Erkek Bağlantı Male Couplers	Not Note	
EAB201	10.000	Yüksek Akış High Flow		3/8 - 18 NPT	91132001	EAB201A	91132005	EAB201B	-
EAB202	10.000	Yüksek Akış High Flow		1/4 - 18 NPT	91132002	EAB202A	91132006	EAB202B	-
EAB203	10.000	Yüksek Akış High Flow		3/8 - 18 NPT	91132003	EAB203A	91132007	EAB203B	ESL-50 ile kullanılır.
EAB204	20.000	Ultra Yüksek Akış Ultra High Flow		1/4 BSP	91132004	EAB204A	91132008	EAB204B	-

Manifoldlar / Manifolds

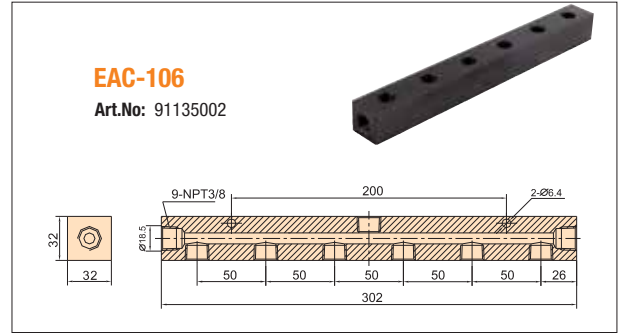
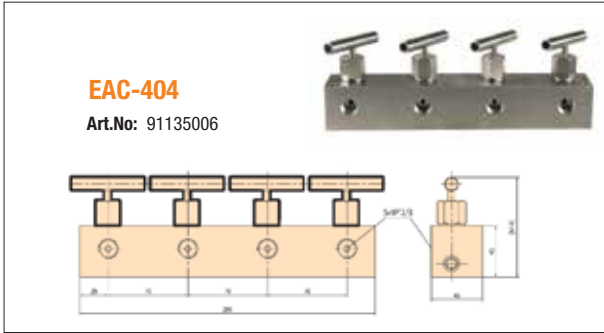
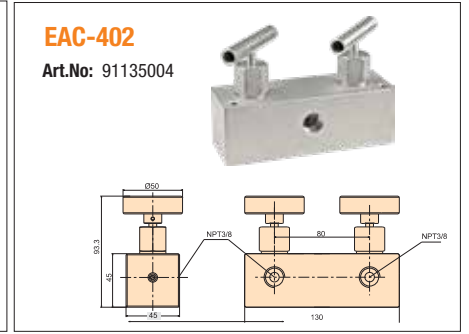
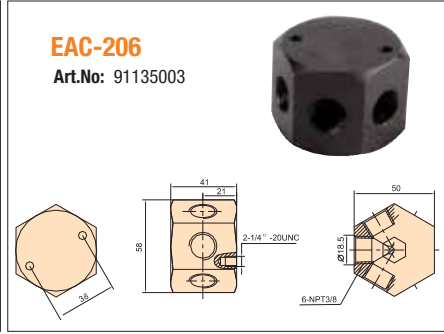
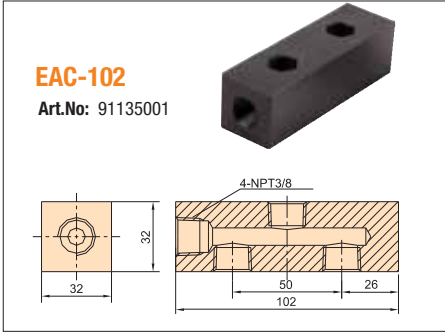





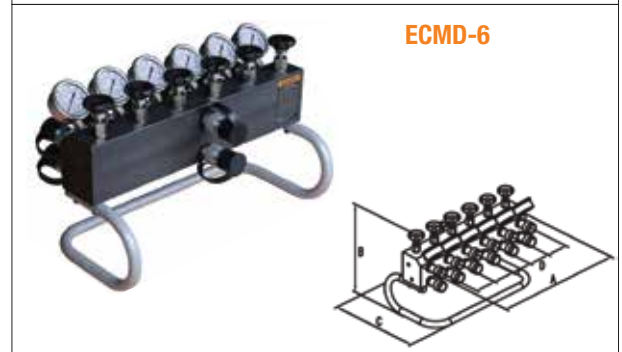
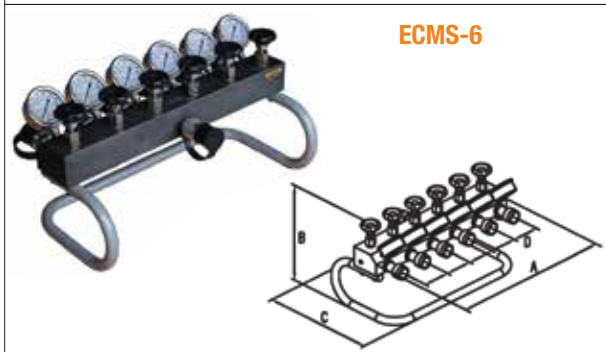
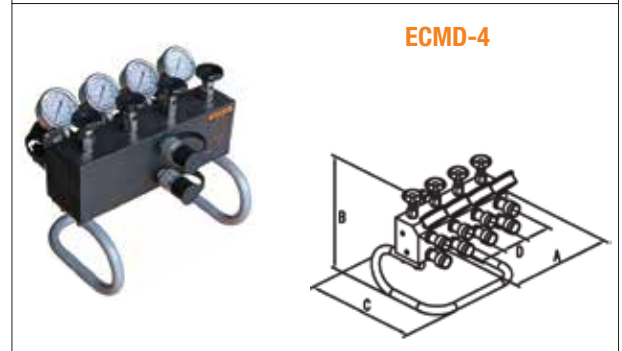
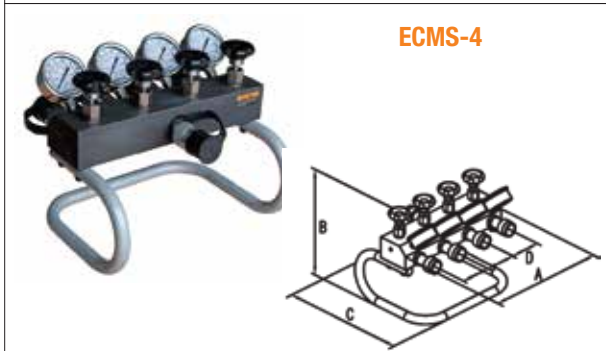
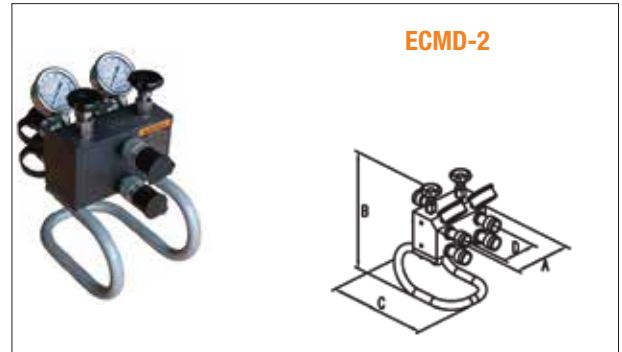
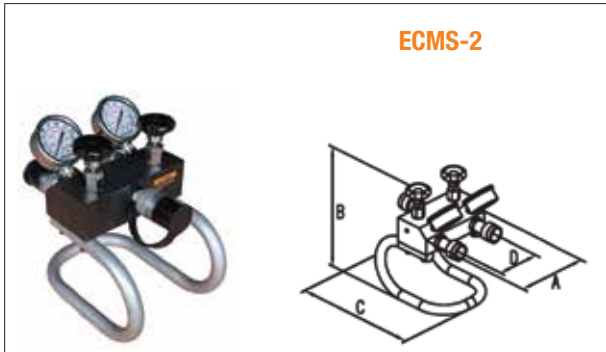





Tek tesirli sistem için / Single Acting Control Manifolds

Çift tesirli sistem için / Double Acting Control Manifolds



EFC SERİSİ / EFC SERIES**BAĞLANTILAR / FITTINGS**

		Boyutlar / Dimensions (mm)
EFC-11 Kod No: 91136005		Bağlantı 3/8-18 NPT Dişiden 3/8-18 NPT Dişiye Coupling From 3/8-18 NPT Female to 3/8-18 NPT Female
EFC-12 Kod No: 91136006		Hekzagon Uç 3/8-18 NPT Erkek, 3/8-18 NPT Erkek, Uzunluk:51mm Hexagon Nipple From 3/8-18 NPT male to, 3/8-18 NPT male, Length:51mm
EFC-13 Kod No: 91136007		Hekzagon Uç 3/8-18 NPT Erkek 3/8-18 NPT Erkek, Uzunluk: 38mm Hexagon Nipple From 3/8-18 NPTmale to 3/8-18 NPT male, Length: 38mm
EFC-14 Kod No: 91136008		Hekzagon Uç 1/4-BSP Erkek 1/4-BSP Erkek Hexagon Nipple From 1/4-BSP male to 1/4-BSP male
EFC-15 Kod No: 91136009		Hekzagon Uç 1/4-18 NPT Erkek 1/4-18 NPT Erkek Hexagon Nipple From 1/4-18 NPT male to 1/4-18 NPT male
EFC-16 Kod No: 91136010		Hekzagon Uç 1/4-18 NPT Erkek 3/8-18 NPT Erkek Hexagon Nipple From 1/4-18 NPT male to 3/8-18 NPT male
EFC-181 Kod No: 91136011		1/4-18 NPT Dişi 1/4-18 NPT Dişi 1/4-18 NPT Female 1/4-18 NPT Female
EFC-21 Kod No: 91136002		Dirsek 1/4-18NPT Erkekten 3/8-18 NPT Dişiye Elbow From 1/4-18 NPT Male to 3/8-18 NPT Female
EFC-22 Kod No: 91136001		Dirsek 3/8-18 NPT Erkekten 3/8-18 NPT Dişiye Elbow From 3/8-18 NPT Male to 3/8-18 NPT Female
EFC-23 Kod No: 91136003		Dirsek 1/4-18NPT Erkekten 3/8-18 NPT Dişiye Elbow From 1/4-18 NPT Male to 3/8-18 NPT Female
EFC-31 Kod No: 91136004		T Bağlantı 3/8-18 NPT Dişi 3/8-18 NPT Dişiden 3/8-18 NPT Dişiye Tee From 3/8-18 NPT Female to 3/8-18 NPT Female and 3/8-18 NPT Female

EG SERİSİ / EG SERIES

YÜKSEK BASINÇ GÖSTERGESİ / HIGH PRESSURE GAUGES



EG2510

EG4010

EG4016

Kod no Code No	Model	Basınç Aralığı Pressure Range		Dış Thread	Gösterge Çapı Gauge Diameter mm
		psi	mpa		
91137001	EG2510	0-10000	0-100	1/4 NPT	64
91137002	EG4010	0-10000	0-100	1/2 NPT	102
91137003	EG4016	0-23000	0-100	M20x1.5	102

Özellikler

- MPa ve psi birimlerinde çift okunmalı, kalibreli ve %1 hassasiyete sahiptir.
- Hızlı ve kolay monte edilebilir.
- Aseismatik (Hareketten etkilenmeyen).
- Paslanmaz çelik malzeme korozyon mukavemetlidir.

Features

- Calibrated with dual scale reading for MPa and psi accuracy, 1 %
- Fast, easy to install.
- Aseismatic- not affected by motion.
- Made of corrosion resistant stainless steel.

EGA SERİSİ / EGA SERIES

GÖSTERGE ADAPTÖRLERİ / GAUGE ADAPTORS

EGA-002/EGA-003/EGA-011

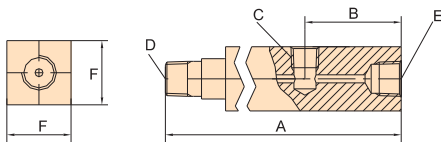

EGA-005

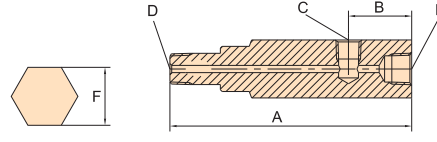

Kod no Code No	Model	Dişi Bağlantı Dişi Female Coupler Thread	Erkek Bağlantı Dişi Male Coupler Thread	Gösterge Dişi Gauge Thread	Ölçüler Sizes (mm)					
					A	B	C	D	E	F
91131002	EGA002	3/8" NPT	3/8" NPT	1/2" NPT	55	35	1/2" NPT	3/8" NPT	3/8" NPT	2
91131003	EGA003	3/8" NPT	3/8" NPT	1/4" NPT	133	48	1/4" NPT	3/8" NPT	3/8" NPT	32
91131004	EGA004	3/8" NPT	1/4" NPT	1/2" NPT	111	35	1/2" NPT	1/4" NPT	3/8" NPT	32
91131005	EGA005	3/8" NPT	3/8" NPT	1/4" NPT	134	35	1/4" NPT	3/8" NPT	3/8" NPT	32
91131006	EGA011	1/4" NPT	3/8" NPT	1/4" NPT	133	48	1/4" NPT	3/8" NPT	1/4" NPT	32



EV SERİSİ / EV SERIES





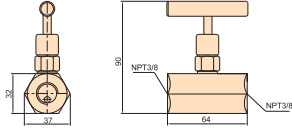

YÖN KONTROL VALFLER DIRECTIONAL CONTROL VALVES

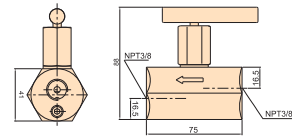

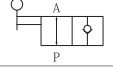
Soldan sağa doğru modeller
Shown from left to right
EV 43M4, EV 11, EV 52H3, EV 23

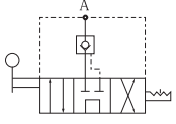
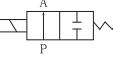
Art. No

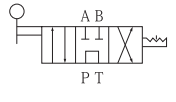
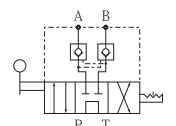
	Art. No Code No 91134001	EV-11		İğne vana, silindiri hızını manuel olarak kontrol etme olanağı sağlar ve geçici yük tutma halinde kapatma vanası olarak da kullanılabilir. Needle valve, manually control the speed of cylinder, can be used as shut-off valve for temporary load holding.
	91134002	EV-23		Manuel çalıştırılan kontrol vanası, tek veya çift tesirli silindirlerde yük tutma amacıyla kullanılır, silindirin indiğinde yağ haznesine dönüşünü sağlamak amacıyla manuel olarak açılır. Manually operated check valve, used to hold load with single or double acting cylinder, manually opened to allow oil to flow back to oil reserve when cylinder retracts.

Kullanıldığı Silindir Used With Cylinder	Valf Çalışması Valve Operation	Valf Konumu Valve Location	Kod no Code No	Model	Valf Tipi Valve Type	Valf Fonksiyonu Valve Function	Hidrolik Sembol Hydraulic Symbol	Ağırlık Weight (kg)
Tek Tesirli Single Acting	Manuel	Pompa Üzerinde Pump Mounted	91134004	EV 42H2	2 Pozisyon 2 Position	İleri- Geri Advance Return		2
	Manuel	Pompa Üzerinde Pump Mounted	91134005	EV 43M3	3 Pozisyon 3 Position	İleri- Tutma-Geri Advance Hold Return		1.3
	Manuel	Kumanda Üzerinde Remote Mounted	91134006	EV 43M3L	3 Pozisyon 3 Position	İleri- Tutma-Geri Advance Hold Return		2.2
	Manuel	Pompa Üzerinde Pump Mounted	91134007	EV 43M3T	3 Pozisyon 3 Position	İleri- Tutma-Geri Advance Hold Return		3.8
	Manuel	Kumanda Üzerinde Remote Mounted	91134008	EV 43M3LT	3 Pozisyon 3 Position	İleri- Tutma-Geri Advance Hold Return		4.7
	Selenoid 24V	Pompa Üzerinde Pump Mounted	91134009	EV 52H2	2 Pozisyon 2 Position	İleri- Geri Advance Return		1.8
	Selenoid 24V	Pompa Üzerinde Pump Mounted	91134010	EV 52H3	2 Pozisyon 2 Position	İleri- Geri Advance Return		1.8
Çift Tesirli Double Acting	Manuel	Pompa Üzerinde Pump Mounted	91134011	EV 43M4	3 Pozisyon 3 Position	İleri- Tutma-Geri Advance Hold Return		1.3
	Manuel	Kumanda Üzerinde Remote Mounted	91134012	EV 43M4L	3 Pozisyon 3 Position	İleri- Tutma-Geri Advance Hold Return		2.2
	Manuel	Pompa Üzerinde Pump Mounted	91134013	EV 43M4T	3 Pozisyon 3 Position	İleri- Tutma-Geri Advance Hold Return		3.8
	Manuel	Kumanda Üzerinde Remote Mounted	91134014	EV 43M4LT	3 Pozisyon 3 Position	İleri- Tutma-Geri Advance Hold Return		4.7
	Selenoid 24V	Pompa Üzerinde Pump Mounted	91134015	EV 52H4	2 Pozisyon 2 Position	İleri- Geri Advance Return		1.8



ENS SERİSİ / ENS SERIES

HİDROLİK SOMUN KESİCİ HYDRAULIC NUT SPLITTERS

Soldan sağa doğru modeller / Shown from left to right
ENS-001, ENS-002, ENS-003, ENS-004, ENS-005,
ENS-006, ENS-007



Özellikler

- Dar alanlarda kullanım için kompakt tasarım.
- Özel kafa açısı tasarımı.
- Tek tesirli, yay dönüşlü silindirlir.
- Somun ayırıcı bıçaklar değiştirilebilir.

Features

- Compact design for use in confined spaces.
- Unique angled head design.
- Single-acting, spring return cylinder.
- Nut splitter blade can be replaced.

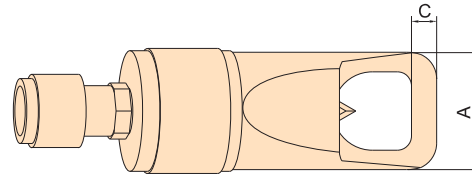
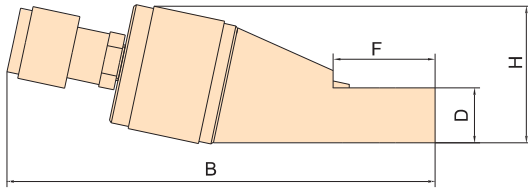



Art.No Code No	Model	Civata Aralığı Bolt Range	Hekzagon Aralığı Hex. nut range	Kapasite Capacity	Yağ Kapasitesi Oil Capacity	Boyutlar / Dimensions						Ağırlık / Weight
						A	B	C	D	F	H	
		mm	mm	ton	cm ³	mm	mm	mm	mm	mm	mm	kg
91128001	ENS001	8-13	12.7-19.1	5	15	40	190	8	19	30	51	1.2
91128002	ENS002	13-16	19.1-23.9	10	20	53	215	10	25	40	65	2
91128003	ENS003	16-22	26.9-31.8	15	30	66	245	13	30	55	80	3.2
91128004	ENS004	22-29	36.6-41.4	20	52	75	285	17	36	67	92	4.5
91128005	ENS005	29-35	46.0-50.8	35	116	93	340	21	43	86	114	8.3
91128006	ENS006	35-38	50.8-57.2	50	181	106	370	23	52	100	128	13.9
91128007	ENS007	38-48	60.5-73.2	90	458	154	450	26	75	125	190	35

SİLİNDİR AKSESUARLARI /

CYLINDER ACCESSORIES

OYNAR PİSTON BAŞLIĞI / TILT SADDLE

Başlıklar				
				
Oynar Başlık Tilt	Yivli Başlık Grooved head	Ortası Delik Başlık Hole Head		
Silindir serisi Cylinder Series	Kapasite Capacity	Oynar Başlık Tilt	Yivli Başlık Grooved Head	Ortası Delik Başlık Hole Head
ES	5		SG-53G	
	10	ST-10*	SG-102G	
	15	ST-10	SG-152G	
	25	ST-50	SG-252G	
	30	ST-50	SG-252G	
	50	ST-100		
	75	ST-100		
ESL*	10	ST-11		
	20-100	ST-51		
ESL**	20			SH-2015
ESH/EDH	30			SH-3015
ESH/EDH	60			SH-5016
ESH/EDH	10			SH-10016
ED	30	ST-50		
	50	ST-100		
	75	ST-100		
ESX/EDX	50	ST-50		
	100	STX-100		
	150	STX-150		
	200	STX-200		
	250	STX-250		
	300	STX-300		
	400	STX-400		
	500	STX-500		
	600	STX-600		
	800	STX-800		
1000	STX-1000			
EL	50-100	ST-100		
	150-200	ST-200		
	250	ST-250		
	300	ST-300		
	400	ST-400		
	500	ST-500		
	600	ST-600		
	800	ST-800		
1000	ST-1000			

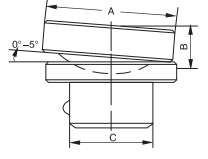
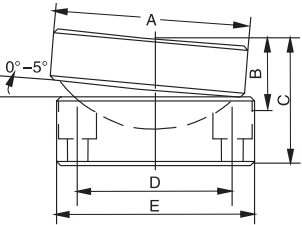
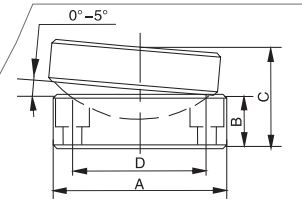
Art. No Code No	Model	A	B	C	D	E	
		mm	mm	mm	mm	mm	
91136012	ST- 10	35	17	21	-	-	
91136013	ST- 50	49	23	36	-	-	
91136014	ST- 100	71	24	37	44	71	
91136015	ST- 200	129	20	45	105	129	
91136016	ST- 250	149	21	46	125	149	
91136017	ST- 300	195	75	100	112	139	
91136018	ST- 400	225	85	110	133	159	
91136019	ST- 500	248	91	116	150	179	
91136020	ST- 600	275	96	121	166	194	
91136021	ST- 800	318	123	148	197	224	
91136022	ST - 1000	357	135	161	221	249	
91136023	STX - 50	49	23	43	39	49	
91136024	STX - 100	72	29	48	55	74	
91136025	STX - 150	91	31	50	74	94	
91136026	STX - 200	118	35	59	90	113	
91136027	STX - 250	144	46	70	119	145	
91136028	STX - 300	158	62	81	150	177	
91136029	STX - 400	193	51	78	170	196	
91136030	STX - 500	228	63	90	200	228	
91136031	STX - 600	241	76	103	220	246	
91136032	STX - 800	296	75	102	260	297	
91136033	STX - 1000	310	93	119	295	323	
91136034	ST - 11	35	11	21	23	-	
91136035	ST - 51	50	15	29	39	-	
91136036	ST - 101	71	17	35	55	-	

*ES-101 Dışında

**ESL düşük profilli silindirlere ile kullanılır.

EHS - EFS SERİSİ / EHS-EFS SERIES

HİDROLİK AYIRICI HYDRAULIC SPREADERS



EHS-0.75

EHS-1

EHS Özellikler

- EHS serisinde tek tesirli, yay dönüşlü silindir kullanılır.
- Basınç ortadan kalktığı zaman ağız kendiliğinden kapanır.
- Ürün üzerinde dişi kaplin ve toz kapağı bulunur.
- Uzun stroklu ayırma işlemi için EHS-075
- Dar alan kullanımı için EHS-1
- ANSI / ASME B 30.1 Standartlarına uygundur.

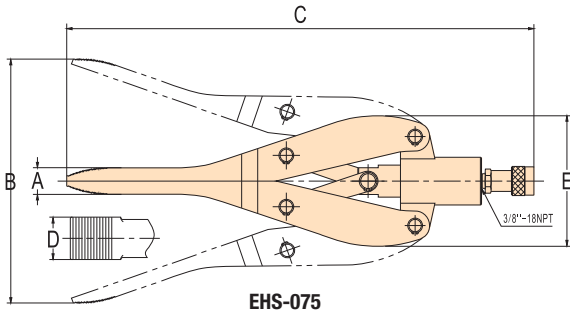

EHS-075

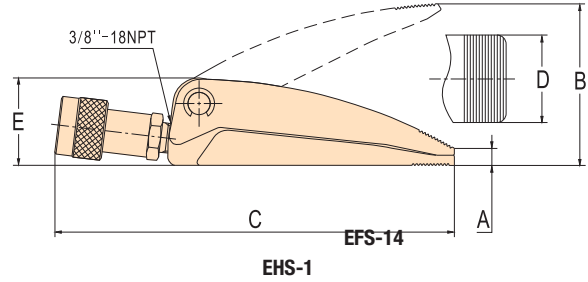

EHS-1

EFS Özellikler

- EFS serisinde tek tesirli, yay dönüşlü silindir kullanılır.
- Basınç ortadan kalktığı zaman ağız kendiliğinden kapanır.
- Emniyet takozu ve toz kapaklı dişi kaplin vardır.
- ANSI / ASME B 30.1 Standartlarına uygundur.

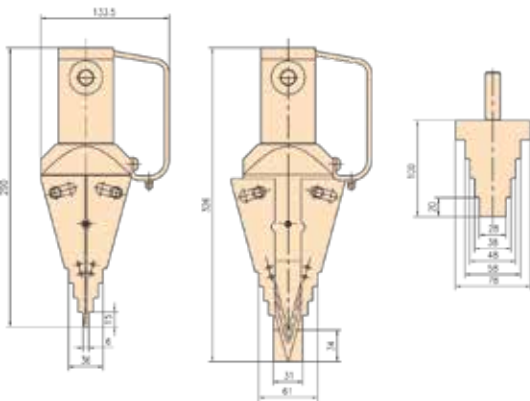

EFS-14



Art.No Code No	Model	Kapasite	Yağ Kapasitesi	Silindir	A	B	C	D	E	Ağırlık Weight
		Capacity	Oil Capacity	Etkelil Alanı						
		ton	cm ³	cm ²	in	in	mm	mm	mm	kg
91141001	EHS-1A	1.1	13,6	6,5	0,47	3,94	231	56	56	2.5
91141002	EHS-075	0.75	55,1	14,5	1,26	11,50	559	51	157	12.5
91141003	EFS -14	14	78,4	14,5	0,24	3,19	290	67	134	7,2

EB SERİSİ / EB SERIES

HİDROLİK GERDİRME HYDRAULIC TENSIONER

EB 206 - EB 207

Art. No	Model	Yük Hücresi Modeli Load Cell Model	Cıvata Ölçüsü Bolt Size	Yük Load KN	Adaptör & Köprü Kit Modeli Adaptor & Bridge Kit Model
91129001	EB201	EB201LC	M20 M22 3/4 7/8	155	EB201AK-M20 EB201AK-M22 EB201AK-3/4 EB201AK-7/8
91129002	EB202	EB202LC	M24 M27 M30 M33 M36 1 1-1/8 1-1/4 1-3/4	456	EB202AK-M24 EB202AK-M27 EB202AK-M30 EB202AK-M33 EB202AK-M36 EB202AK-1 EB202AK-1-1/8 EB202AK-1-1/4 EB202AK-1-3/4
91129003	EB203	EB203LC	M39 M42 1-1/2 1-5/8	763	EB203AK-M39 EB203AK-M42 EB203AK-1-1/2 EB203AK-1-5/8
91129004	EB204	EB204LC	M45 M48 1-3/4 1-7/8	989	EB204AK-M45 EB204AK-M48 EB204AK-1-3/4 EB204AK-1-7/8
91129005	EB205	EB205LC	M52 M56 2 2-1/4	1346	EB205AK-M52 EB205AK-M56 EB205AK-2 EB205AK-2-1/4
91129006	EB206	EB206LC	M60 M64 M68 2-1/2	1649	EB206AK-M60 EB206AK-M64 EB206AK-M68 EB206AK-2-1/2
91129007	EB207	EB207LC	M72 M76 2-3/4 3	2191	EB207AK-M72 EB207AK-M76 EB207AK-2-3/4 EB207AK-3
91129008	EB208	EB208LC	M80 M85 M90 3-1/4 3-1/2	2544	EB208AK-M80 EB208AK-M85 EB208AK-M90 EB208AK-3-1/4 EB208AK-3-1/2
91129009	EB209	EB209LC	M95 M100 3-3/4	3101	EB209AK-M95 EB209AK-M100 EB209AK-3-3/4
91129010	EB210	EB210LC	M105 M110 M115	3796	EB210AK-M105 EB210AK-M110 EB210AK-M115

EB SERİSİ / EB SERIES**HİDROLİK GİRDİRME
HYDRAULIC TENSIONER****Özellikler**

- 10 yük hücresi mevcuttur.
- Hafif ve hassasiyeti yüksektir.
- Tam görüntü için köprü penceresi bulunur.Farklı cıvatalar için değiştirilebilir yük hücresine sahiptir.
- Köprüler kolay montaj için çıkarılabilir ve döndürülebilir yapıdadır.

Features

- 10 Load cells available.
- Light weight, and accurate.
- Bridge window for full viewing.
- Removable load cell for different sized bolts.
- Bridges are removable and rotate for easy installation.

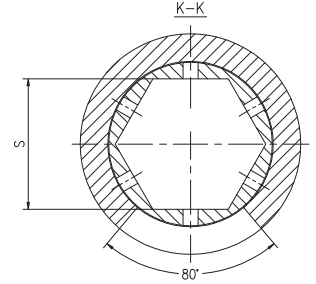
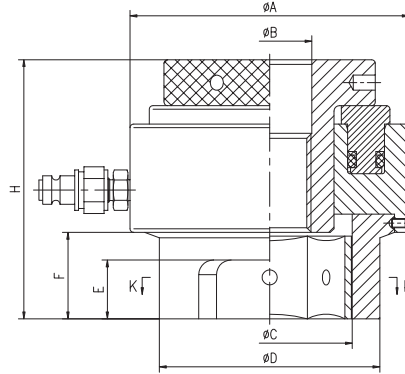

Boyutlar / Dimensions								Strok Stroke
A	B	C	D	E	F	H	S	mm
mm	mm	mm	mm	mm	mm	mm	mm	mm
80	20.5	43	62	16	23	91	31	9.9
		45					33	
		43					31	
		45					33	
110	25	54	73	18	37	111	37	
	28	57	75	20	30	114	42	
	31	62	81	20	32	116	47	
	34	69	88	20	35	119	51	
	37	74	96	26	38	122	56	
	28	57	75	20	30	114	39	
134	31	62	81	20	32	116	44	
	34	69	88	20	35	119	49	
	37	74	96	26	38	122	53	
	40	80	100	28	41	133	61	
	43	85	108	30	44	136	66	
152	40	80	100	28	41	133	58	
	43	85	108	30	44	136	63	
	46	90	120	32	47	141	71	
	49	95	125	32	50	144	76	
177	46	90	120	32	47	141	68	
	49	95	125	32	50	144	76	
	53	103	132	38	54	154	81	
200	57	106	140	38	58	158	86	
	53	103	132	38	50	144	77	
	59	115	150	41	62	164	90	
	61	115	150	41	62	164	91	
225	65	120	156	45	66	168	96	
	69	126	164	45	70	172	101	
	65	126	164	45	70	172	100	
	73	135	185	50	74	189	106	
255	77	140	190	52	78	193	111	
	72	140	190	52	78	193	109	
	78	146	206	60	82	202	118	
	81	146	206	60	82	202	116	
282	86	155	210	60	87	207	121	
	91	165	225	60	92	212	131	
	84	165	225	60	92	212	128	
	92	173	235	65	98	224	137	
320	97	173	235	65	98	224	136	
	102	186	245	70	103	229	146	
	97	186	245	70	103	229	147	
320	-	197	275	70	107	242	152	
	-	202	275	75	112	247	157	
	-	212	275	80	117	252	167	

ESW SERİSİ / ESW SERIES

KARE BAŞLIKLİ HİDROLİK TORK ANAHTARI TORQUE WERNCH



Yağ giriş noktası 360° dönme özelliğine sahiptir.
Swiveling inlet port rotates 360 degrees

360° ince ayar tipi reaksiyon kolu
360° fine-tune type reaction arm

Özellikler

- 70 Mpa max. çalışma basıncı \pm % 3 hassasiyete sahiptir.
- 189 Nm - 48670 Nm aralığında 8 model, bir çok civata ölçüsünü kapsar.
- Bağlantı için kullanılan kare başlık tipi ile hızlı bir şekilde aparat değişikliği yapılabilir.
- 360° dönebilen bağlantı noktası rahat çalışma olanağı sağlar.
- Isıl işlem uygulanmıştır.

Features

- 70Mpa Max working pressure and the accuracy keep within \pm 3%.
- All together 8 models with the range from 189 N.m to 48670 N.m Which covers most bolts size, and becomes the comprehensive available in the market
- The square drive operate with the high intense socket and suitable with large rangers of bolts
- 360 degree adjustable reaction arm allows placing freely.
- Well heat-treated, lifetime warranty.

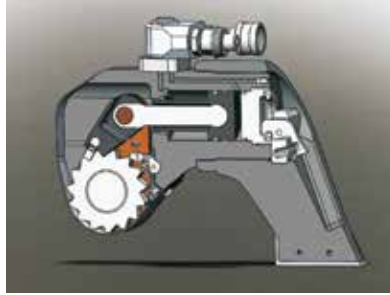

Hızlı ve verimli çalıştırma 35° dönüş açısı ve hızlı geri dönüş stroku

Fast and efficient operation. 35° rotation angle and fast return stroke

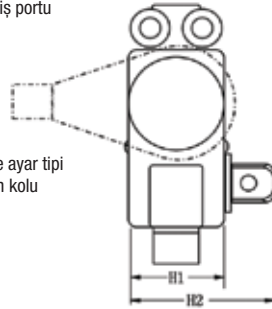
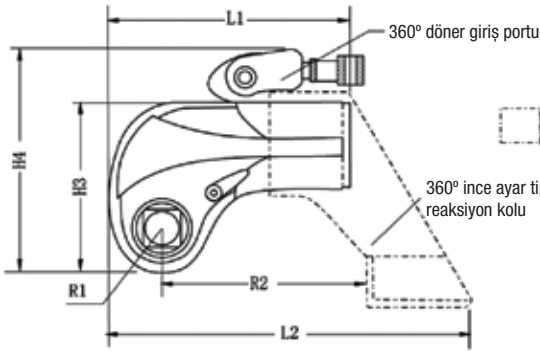

Art. No Code No	Model	Kare başlık ebadı Square drive	Tork kapasitesi Tension range	Civata/Somun aralığı Bolts range	Ağırlık Weight	L1	L2	H1	H2	H3	H4	R1	R2
		in	N.m	mm	kg	mm	mm	mm	mm	mm	mm	mm	mm
91126001	ESW-1	3/4"	189-1897	16-36	2	130	182	50	72	99	144	26	99
91126002	ESW-3	1"	450-4510	22-48	4	166	241	68	95	130	176	34	134
91126003	ESW-5	1-1/2"	737-7368	27-56	7	198	281	80	123	155	198	39	152
91126004	ESW-8	1-1/2"	1078-10784	30-64	9,1	213	308	90	130	171	216	47	171
91126005	ESW-10	1-1/2"	1550-15503	36-72	13,1	231	336	100	141	187	230	51	174
91126006	ESW-20	2-1/2"	2666-26658	42-90	25	295	443	120	182	228	268	59	250

DİKKAT : Uygulamanız için doğru tork anahtarı modelini seçtiğinizden emin olunuz. Gevşetme torku, sıkma torkundan yaklaşık %250 daha fazla tork gerektirir.

ESWT SERİSİ / ESWT SERIES

KARE BAŞLI HİDROLİK TORK ANAHTARI SOKETLERİ SOCKETS FOR SQUARE DRIVE HYDRAULIC TORQUE WRENCH

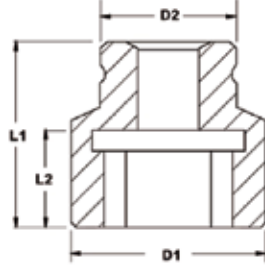

Özellikler

- Yüksek standart krom alaşım malzemeden yapılmıştır.
- Standart ısı işlem ve özel işlem görmüştür.

Features

- Made of high standard chromium alloy material.
- With a standard heat treatment, long-life treatment.

Art No Code No	Model	Tork Anahtar Modeli Wrench Model	Kade Başlık Ebadı Size	Civata Ölçüsü Bolts size	Çapraz Ölçü Across Side	L1	L2	D1	D2
						mm	mm	mm	mm
91170101	ESWT-75024	ESW-1	3/4"	M16	24	54	32	40	40
91170102	ESWT-75027			M18	27	54	32	42	42
91170103	ESWT-75030			M20	30	54	33	46	44
91170104	ESWT-75034			M22	34	54	32	48	44
91170105	ESWT-75036			M24	36	57	32	53	44
91170106	ESWT-75041			M27	41	58	33	60	44
91170107	ESWT-75046			M30	46	63	38	66	44
91170108	ESWT-75050			M33	50	65	40	71	44
91170109	ESWT-75055			M36	55	70	45	77	54
91170096	ESWT-10030			ESW-3	1"	M20	30	59	32
91170047	ESWT-10034	M22	34			59	32	58	58
91170048	ESWT-10036	M24	36			62	32	59	59
91170049	ESWT-10041	M27	41			65	38	67	54
91170050	ESWT-10046	M30	46			65	38	74	54
91170051	ESWT-10050	M33	50			70	43	79	60
91170052	ESWT-10055	M36	55			80	52	84	60
91170053	ESWT-10060	M39	60			85	57	89	60
91170054	ESWT-10065	M42	65			85	58	98	70
91170055	ESWT-10070	M45	70			90	62	104	70
91170056	ESWT-10075	M48	75	95	65	108	70		
91170057	ESWT-15036	ESW-5	1-1/2"	M24	36	85	44	74	74
91170058	ESWT-15041			M27	41	85	44	74	74
91170059	ESWT-15046			M30	46	85	44	74	74
91170060	ESWT-15050			M33	50	90	45	79	79
91170061	ESWT-15055			M36	55	90	45	84	84
91170062	ESWT-15060			M39	60	100	45	94	84
91170063	ESWT-15065			M42	65	100	45	98	80
91170064	ESWT-15070			M45	70	105	50	104	80
91170065	ESWT-15075			M48	75	110	50	118	85
91170066	ESWT-15080			M52	80	115	55	118	90
91170067	ESWT-15085	ESW-8	1-1/2"	M56	85	125	60	128	90
91170068	ESWT-15090			M60	90	125	60	139	90
91170069	ESWT-15095			M64	95	130	65	139	90
91170070	ESWT-15100			M68	100	135	70	144	90
91170071	ESWT-15105			M72	105	135	70	149	90
91170072	ESWT-15110			M76	110	135	70	158	90
91170073	ESWT-15115			M80	115	135	70	159	90
91170074	ESWT-15120			M85	120	135	70	168	95
91170075	ESWT-15130			M90	130	155	93	189	95
91170076	ESWT-15130			M90	130	155	93	189	95
91170081	ESWT-25055	ESW-10	2-1/2"	M36	55	100	57	86	114
91170082	ESWT-25060			M39	60	100	52	119	119
91170083	ESWT-25065			M42	65	100	52	119	119
91170084	ESWT-25070			M45	70	120	67	128	128
91170085	ESWT-25075			M48	75	120	67	128	128
91170086	ESWT-25080			M52	80	130	71	128	128
91170087	ESWT-25085			M56	85	130	71	129	129
91170088	ESWT-25090			M60	90	140	73	139	139
91170089	ESWT-25095			M64	95	140	73	139	139
91170090	ESWT-25100			M68	100	140	81	148	130
91170091	ESWT-25105	ESW-20	2-1/2"	M72	105	150	89	149	130
91170092	ESWT-25110			M76	110	150	90	158	130
91170093	ESWT-25115			M80	115	150	98	168	130
91170094	ESWT-25120			M85	120	150	98	178	130
91170095	ESWT-25130			M90	130	170	98	188	130
91170096	ESWT-25135			M95	135	170	114	198	130
91170097	ESWT-25145			M100	145	0	122	210	152
91170098	ESWT-25150			M105	150	190	140	216	152
91170099	ESWT-25155			M110	155	190	140	229	152
91170100	ESWT-25165			M115	165	190	140	241	152

EHW SERİSİ / EHW SERIES

HEKZAGON TORK ANAHTARI HEXAGON TORQUE WRENCH

Tork Anahtarı Tablosu

Art. No Code No	Model	Tork Kapasitesi Torque range	Altıgen Soket Ebadı Bolt across side	Güç Ünitesi Aralığı Power unit	Kaset Aralığı Cassette	L	H1	H2	W1	W2
		Nm	s	kg	kg	mm	mm	mm	mm	mm
91127001	EHW-2	228-2278	1955	1	1.6	196.4	125.9	102.3	32	51
	EHW-2SO	243-2427	60	1	1.7	196.4	128.5	105	32	51
91127002	EHW-4	586-5862	34-65	2	4.4	245	177	135.7	42	66
	EHW-4SO	643-6437	70-80	2	4.6	246	187	145.7	42	66
91127003	EHW-8	1103-11981	41-95	3.3	8	300	207	169	53	83
	EHW-8SO	1181-11807	100-105	3.3	8.4	301	216	178	53	83
91127004	EHW-14	1560-15653	50-117	5.5	11.6	361	239	204	64	99

DİKKAT : Uygulamanız için doğru tork anahtarı modelini seçtiğinizden emin olunuz.

Gevşetme torku, sıkma torkundan yaklaşık %250 daha fazla tork gerektirir.

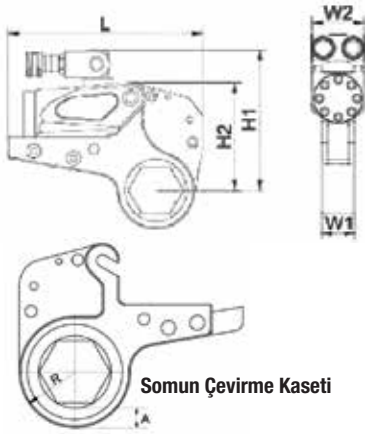

Somun Çevirme Kaseti

Özellikler

- 70 Mpa max. çalışma basıncı ve \pm %3 hassasiyete sahiptir.
- 228 - 44613 Nm aralığında 5 model
- 360°*180 ve 360°*360° döner yapısı ile yer sıkıntısı olmadan çalışma imkanı sağlar.
- Tork anahtarı somun üzerinde daha hassas ve kolay çalışır.
- Uzun kolu ve kompakt gövdesi ile rahat kullanım kolaylığı sağlar.

Features

- 70Mpa Max working pressure and the accuracy keep within \pm 3%.
- 5 with range from 228-44613 N.m.
- 360°*180 degree swivel & 360°*360 degree swivel allow the wrench free to operate with space limitation.
- More accurate and easier for the wrench to work directly on the nuts.
- Compact design with long arm fully advances the reliability.

Yağ giriş noktası 360° dönme özelliğine sahiptir.
Swiveling inlet port rotates 360 degrees



Hızlı bağlantı değişimini sağlayan tasarım.
Simple, tool free design for fast link changes on the job site



Hızlı ve verimli çalıştırma 35° dönüş açısı ve hızlı geri dönüş stroku

Fast and efficient operation. 35° rotation angle and fast return stroke

Kaset Tablosu

Cıvata başı Somun ölçüsü Bolts dia. mm	EHW-2 Kaset modeli Cassette model	EHW-4 Kaset modeli Cassette model	EHW-8 Kaset modeli Cassette model	EHW-14 Kaset modeli Cassette model
19	EHWL2-34			
21	EHWL2-1316			
22	EHWL2-78			
24	EHWL2-1516			
25	EHWL2-1	EHWL4-1		
27	EHWL2-1116	EHWL4-1116		
29	EHWL2-118	EHWL4-118		
30	EHWL2-11316	EHWL4-11316		
32	EHWL2-114	EHWL4-114		
33	EHWL2-11516	EHWL4-11516		
35	EHWL2-138	EHWL4-138		
36	EHWL2-1716	EHWL4-1716		
38	EHWL2-112	EHWL4-112		
40	EHWL2-1916	EHWL4-1916		
41	EHWL2-158	EHWL4-158		
43	EHWL2-11116	EHWL4-11116		
44	EHWL2-134	EHWL4-134		
46	EHWL2-11316	EHWL4-11316		
48	EHWL2-178	EHWL4-178	EHWL8-178	
49	EHWL2-11516	EHWL4-11516	EHWL8-11516	
50	EHWL2-2	EHWL4-2	EHWL8-2	
52	EHWL2-2116	EHWL4-2116	EHWL8-2116	
54	EHWL2-218	EHWL4-218	EHWL8-218	
55	EHWL2-2316	EHWL4-2316	EHWL8-2316	
57	EHWL2-214	EHWL4-214	EHWL8-214	
59	EHWL2-2516	EHWL4-2516	EHWL8-2516	
60	EHWL2-238	EHWL4-238	EHWL8-238	EHWL14-238
62		EHWL4-2716	EHWL8-2716	EHWL14-2716
63		EHWL4-212	EHWL8-212	EHWL14-212
75		EHWL4-2916	EHWL8-2916	EHWL14-2916
67		EHWL4-258	EHWL8-258	EHWL14-258
68		EHWL4-21116	EHWL8-21116	EHWL14-21116
70		EHWL4-234	EHWL8-234	EHWL14-234
71		EHWL4-21316	EHWL8-21316	EHWL14-21316
73		EHWL4-278	EHWL8-278	EHWL14-278
75		EHWL4-21516	EHWL8-21516	EHWL14-21516
76		EHWL4-3	EHWL8-3	EHWL14-3
78		EHWL4-3116	EHWL8-3116	EHWL14-3116
80		EHWL4-318	EHWL8-318	EHWL14-318
81			EHWL8-3316	EHWL14-3316
83			EHWL8-314	EHWL14-314
84			EHWL8-3516	EHWL14-3516
85			EHWL8-338	EHWL14-338
87			EHWL8-3716	EHWL14-3716
89			EHWL8-312	EHWL14-312
91			EHWL8-3916	EHWL14-3916
92			EHWL8-358	EHWL14-358
94			EHWL8-31116	EHWL14-31116
95			EHWL8-334	EHWL14-334
97			EHWL8-31316	EHWL14-31316
98			EHWL8-378	EHWL14-378
100			EHWL8-31516	EHWL14-31516
102			EHWL8-4	EHWL14-4
103				EHWL14-4116
105				EHWL14-418
106				EHWL14-4316
108				EHWL14-414
110				EHWL14-4516
111				EHWL14-438
113				EHWL14-4716
114				EHWL14-412
116				EHWL14-4916
117				EHWL14-458

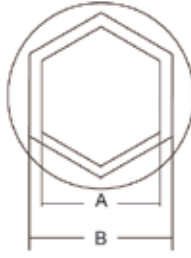

EHW SERİSİ / EHW SERIES

DARALTICI BURÇLAR CASSETTE REDUCER

Özellikler

- Başlıkların ebadını küçültmek için daraltıcı burçlar kullanılır.
- Çok güçlü alaşım malzemeden mamüldür.

Tork Anahtarı Modeli Wrench model	Kaset Modeli Cassette Model	Kaset Cıvata Baş / Somun Ölçüsü Link Bolt Head/Nut Size mm	Burç modeli Reducer Model	Burç Cıvata Baş / Somun Ölçüsü Reducer Bolt Head/Nut Size mm
EHW-2	EHWL2-1716	36	E23628	29
	EHWL2-158	41	E24130	30
	EHWL2-11316	46	E24131	32
			E24622	27
			E24632	32
	EHWL2-2	50	E24636	36
			E25032	32
			E25036	36
	EHWL2-2316	55	E25041	41
			E25536	36
			E25541	41
			E25546	46
	EHWL2-238	60	E26041	41
			E26046	46
E26050			50	
EHW-4	EHWL4-2	50	E45047	48
	EHWL4-2316	55	E45536	36
			E45541	41
			E45546	46
	EHWL4-238	60	E46035	35
			E46036	36
			E46046	46
			E46050	50
	EHWL4-2716	62	E46250	50
	EHWL4-212	63	E46346	46
			E46350	50
			E46334	52
	EHWL4-2916	65	E46546	46
			E46550	50
			E46554	54
			E46555	55
	EHWL4-234	70	E47050	50
			E47055	55
E47060			60	
EHWL4-21516	75	E47550	50	
		E47555	55	
		E47560	60	
		E47565	65	
EHWL4-318	80	E48050	50	
		E48054	54	
		E48060	60	
		E48065	65	
		E48070	70	
		E48075	75	

Features

- Super strong alloy making.
- Customizability of all kinds of spacer shell.

Tork Anahtarı Modeli Wrench model	Kaset Modeli Cassette Model	Kaset Cıvata Baş / Somun Ölçüsü Link Bolt Head/Nut Size mm	Burç modeli Reducer Model	Burç Cıvata Baş / Somun Ölçüsü Reducer Bolt Head/Nut Size mm
EHW-8	EHWL8-2916	65	E86550	50
	EHWL8-234	70	E87050	50
			E87055	55
			E87060	60
	EHWL8-21516	75	E87555	55
			E87560	60
			E87565	65
	EHWL8-318	80	E88050	50
			EE88055	55
			E88060	60
			E88065	65
	EHWL8-312	89	E88070	70
			E89070	70
			E89075	75
EHWL8-312	89	E89076	76	
		E89077	77	
		E89080	80	
EHWL8-31116	94	E89370	70	
EHWL8-334	95	E89570	70	
		E89575	75	
		E89580	80	
EHWL8-378	98	E89875	75	
		E89880	80	
EHW-14	EHWL14-3	76	E147654	29
	EHWL14-318	80	E148060	60
			E148065	65
			E148070	70
	EHWL14-312	89	E149075	59
			E149070	70
			E149080	80
	EHWL14-31116	94	E149575	59
			E149570	70
			E149580	80
	EHWL14-378	98	E140075	75
			E140080	80
E140090			89	
EHWL14-414	108	E1411090	89	
		E1411095	94	
		E14110100	98	
EHWL14-458	117	E1411795	94	
		E14117100	98	
		E14117110	108	

TWP SERİSİ / EHW SERIES

HİDROLİK TORK ANAHTAR POMPASI HYDRAULIC TORQUE WRENCH PUMPS

Kablolu uzaktan kumanda

Hand held remote control for easy operation

Pompa üzerinde standart aksesuar olarak dahili yağ soğutucu bulunmaktadır.

This pump comes with built-in oil cooling as a standard feature enabling you to be more productive.

İstenen tork seviyesine ulaşmak için basıncı ayarlamaya yarayan kilitlebilir basınç valfi

Fully adjustable-and lockable pressure valve, Allows you to set the pressure you need to achieve the right amount of torque

Yüksek mukavemetli, hafif ve alüminyum alaşım hazne ve pompa gövdesi

High strength, tight weight, aluminum alloy reservoir and pump body making it extremely portable

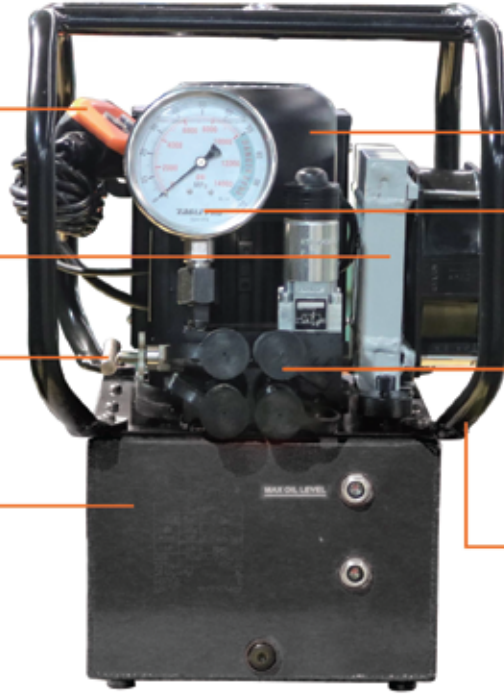
**Yüksek verimli TEFC endüksiyon motoru**

High efficiency TEFC induction motor starts under the toughest loads

Basınç göstergesi ve yağ seviye görüşü

Easy to read pressure gauge and oil level sight ensure your pump is working properly

4 çıkışlı vana, 2 adet tork anahtarının aynı anda çalışmasına müsaade eder.

4 Port valve design allows operation of 2 torque wrenches at the same time

Dayanımlı yüksek mukavemetli alüminyum pompa kafesi zor şartlarda pompayı korur.

High strength aluminum roll cage protects the pump in the harshest environments

Art. No	Tork Anahtarı Sayısı Wrench Quantity	Model	Akış Oranı / Flow Rate l / dk			Yağ Kapasitesi Oil Capacity l	Hazne Ölçüsü Reservoir Size mm	Motor	Ağırlık (Yağsız) Weight (Without oil) kg
			1. Kademe 1. Stage	2. Kademe 2. Stage	3. Kademe 3. Stage				
91124021	1 veya 2 / 1 or 2	TWP - 3AF	8	1.52	0.76	6	430*330*472	220V, 50HZ, 1.3HP	27.5

Tork Anahtarı için Hidrolik Hortum

Hydraulic Hose for torque wrench



Tork Anahtarı için Hidrolik Hortum

Hydraulic Hose for torque wrench

Art No Code No	Model	Uzunluk / Length (m)
91170043	EH - 15	4.5
91170044	EH - 20	6.0
91170045	EH - 40	12.0

Çubuk Bağlantıları

Quick Cople



Art No Code No	Model	Dış Ölçüsü Screw Model	Tanım Description
91132013	EAB - 202 TA	1/4 - 18 NPT	Dişi / Female
91132014	EAB - 202 TB		Erkek / Male
91132015	EAB - 202 T		Dişi&Erken / Female&Male

ÇEVİRİM TABLOSU / CONVERSION TABLE

	Çarpan By	Birim To Get	Çarpan By	Birim Unit
Birim Unit	Faktör Factor	Birim Unit	Faktör Factor	Birim Unit
Uzunluk / Length				
Milimetre / Milimeter (mm) (1inch=25.4 mm)	x0.03937	=inc	x25.4	= mm
Santimetre / Centimeter (cm) 10mm	x0.3937	=inc	x2.54	= cm
Metre / Meter (m) 1000 mm	x3.28	=foot	x0.305	= m
Metre/ Meter (m)	x1.09	=yard	x0.914	= m
Kilometre / Kilometer (km) 1000m	x0.62	=mile	x1.61	= km
Alan / Area				
Milimetre / Milimeter (mm²)	x0.00155	=inch ²	x645	= mm ²
Santimetre / Centimeter (cm²)	x0.155	=inch ²	x6.45	= cm ²
Metre² / Meter² (m²)	x10.8	=foot ²	x0.0929	= m ²
Metre² / Meter² (m²)	x1.2	=yard ²	x0.836	= m ²
Hektare / Hectar (ha) 10.000 m²	x2.47	=acre	x0.405	= ha
Kilometre / Kilometer (km²)	x0.39	=mile ²	x2.59	= km ²
Hacim / Volume				
Santimetre / Centimeter (cm³)	x0.061	=inch ³	x16.4	= cm ³
Litre / Liters (l)	x61	=inch ³	x0.018	= L
Milimetre / Milimeter (ml)	x0.034	=fl oz	x29.6	= ml =1cm ³
Litre / Liters (l) 1000 ml	x1.061	=guart	x0.946	= L
Litre / Liters (l)	x0.26	=gallon	x3.79	= L
Metre³ (m³) 1000l	x1.3	=yard ³	x0.76	= m ³
Akış / Flow				
Litre-dakika / Liters-Min	x61.024	=cu.in/ min	x0.016	=liters/ min (litre/ dk)

	Çarpan By	Birim To Get	Çarpan By	Birim Unit
Birim Unit	Faktör Factor	Birim Unit	Faktör Factor	Birim Unit
Ağırlık / Mass				
Gram / Gram (g)	x0.035	=ounce	x28.3	= g
Kilogram / Kilogram (kg) 1000 g	x2.2	=pound	x0.454	= kg
Ton / Tonne (t) 1000 kg	x1.1	=short ton	x0.907	=T
Kuvvet / Force (N=kg* m/s²)				
Newton (N)	x0.225	=pound	x4.45	=N
Kilonewton	x225	=pound	x0.00445	=KN
Tork / Torque				
Newtonmetre / newtonmeter (N.M)	x8.9	=lb. in.	x0.113	=N.m
Newtonmetre / newtonmeter (N.M)	x0.74	=lb. ft.	x1.36	=N.m
Basınç Pressure (Pa=N/ m²)				
Kilopaskal (kPa)	x4.0	=in.H2O	x0.249	=kPa
Kilopaskal (kPa)	x0.3	=in.Hg	x3.38	=kPa
Kilopaskal (kPa)	x0.145	=psi	x6.89	=kPa
Megapaskal (MPa)	x145	=psi	x0.00689	=MPa
Bar	x14.5	=psi	x0.0689	=Bar
Güç / Power (w=J/s)				
Watt (kw)	x0.74	=ft.lb/s	x1.36	=kw
Kilowatt (kw)	x0.948	=Btu/s	x1.055	=kw
Kilowatt (kw)	x1.34	=hp	x0.746	=w
Sıcaklık / Temperature				
"F=(°C x 9/5)+32"		"°C=(F-32) x 5/9"		



NETMAK TEST MERKEZİ

200 ton - 8 metre Yatay Test Makinesi



- Çelik halat sapan, zincir sapan, polyester sapan gruplarının çekme ve koparma testleri için özel tasarlanmıştır
- Test makinesi bilgisayarlı kontrol sistemi tarafından desteklenir.
- Diyagramlı olarak test sonuçlarının otomatik olarak print alınmasını sağlar.
- İş güvenliğini en iyi seviyede sağlamak üzere hidrolik çalışan koruma kapağı bulunur.
- Uzama ölçümü yapar.



1000 ton Hidrolik Test Makinesi

- 1 tondan 1000 tona kadar olan hidrolik - mekanik silindir ve krikoların kapasite testleri
- Pompa ve hortum sızdırmazlık ve kapasite testleri gerçekleştirilir.





■ **Polyester Sonsuz Halatlar**
Polyester Round Slings

■ **Polyester Sapanlar**
Polyester Webbing Slings

■ **Zincir Sapanlar**
Chain Slings

■ **Kancalar**
Hooks

■ **Mapalar**
Eye Bolts

SAPANLAR ve AKSESUARLARI
SLINGS AND ACCESSORIES

POLYESTER SONSUZ HALAT (SF 7:1) / POLYESTER ROUND SLING

Düz kaldırma kapasitesi/ Straight lifting capacity (WLL)	Sonsuz Halat Uzunlukları/ Length of round sling (L1) m						
	2m	3m	4m	5m	6m	8m	
1.000 kg	Art.No. 56510102	56510103	56510104	56510105	56510106	56510108	
2.000 kg	Art.No. 56510202	56510203	56510204	56510205	56510206	56510208	
3.000 kg	Art.No. 56510302	56510303	56510304	56510305	56510306	56510308	
4.000 kg	Art.No. 56510402	56510403	56510404	56510405	56510406	56510408	
5.000 kg	Art.No. 56510502	56510503	56510504	56510505	56510506	56510508	
6.000 kg	Art.No. 56510602	56510603	56510604	56510605	56510606	56510608	
8.000 kg	Art.No. 56510802	56510803	56510804	56510805	56510806	56510808	
10.000 kg	Art.No. 56511002	56511003	56511004	56511005	56511006	56511008	

Emniyet faktörü: 7:1
Safety factor: 7:1

* Farklı ölçüler için satış temsilcilerimizle iletişime geçiniz.

* Please contact our sales department for different capacities.

SONSUZ HALATLAR - KAPASİTESİ TABLOSU (kg)							
Renk Kodu	Düz kaldırma	Boğma	U kaldırma	Açılı kaldırılmalar			
				0° - 45°	45° - 60°	0° - 45°	45° - 60°
	500	400	1000	700	500	350	250
	1000	800	2000	1400	1000	700	500
	2000	1600	4000	2800	2000	1400	1000
	3000	2400	6000	4200	3000	2100	1500
	4000	3200	8000	5600	4000	2800	2000
	5000	4000	10000	7000	5000	3500	2500
	6000	4800	12000	8400	6000	4200	3000
	8000	6400	16000	11200	8000	5600	4000
	10000	8000	20000	14000	10000	7000	5000

SF7 / EN 1492-2

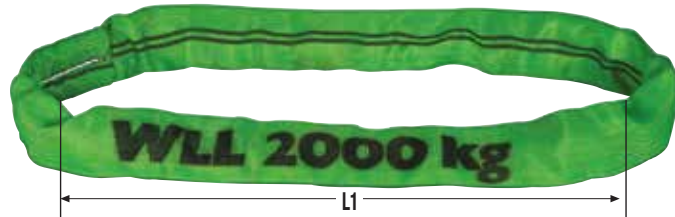

- EN 1492-2 ve Makine Emniyet Yönetmeliği 2006/ 42 EC' ye göre üretilmiştir.
- Sonsuz halatlar bükülmüş polyester elyafın özel bir teknikle birleştirilmesi yolu ile imal edilmekte olup, elyafın üzeri yine polyesterden mamul dokuma bir kılıf ile korunmaktadır.
- Polyester sonsuz halatlar yumuşak dokulu özelliklerinden dolayı kaldırılacak malzemenin şeklini alır ve esnek yapıları nedeni ile kullanım kolaylığı sağlar.
- Manufactured according to EU Machinery Directive 2006/ 42 EC and EN 1492-2
- The carrying element of a PES roundsling are endlessly haid, high quality polyester fibre yarns which protected by a coat of seamless wovnen and impregnated polyester web.
- The use of roundslings contains many advantages like high working load limits with low own-Weights, good adaptability to the goods, pleasand handling without problems etc.



POLYESTER SAPAN (SF 7:1) / POLYESTER WEBBING SLING (SF 7:1)

Düz kaldırma kapasitesi/ Straight lifting capacity (WLL)	Polyester Sapan Uzunlukları/ Length of polyester sling (L1) m						
	2m	3m	4m	5m	6m	8m	10m
1.000 kg	Art.No. 56710102	56710103	56710104	56710105	56710106	56710108	56710110
2.000 kg	Art.No. 56710202	56710203	56710204	56710205	56710206	56710208	56710210
3.000 kg	Art.No. 56710302	56710303	56710304	56710305	56710306	56710308	56710310
4.000 kg	Art.No. 56710402	56710403	56710404	56710405	56710406	56710408	56710410
5.000 kg	Art.No. 56710502	56710503	56710504	56710505	56710506	56710508	56710510
6.000 kg	Art.No. 56710602	56710603	56710604	56710605	56710606	56710608	56710610
8.000 kg	Art.No. 56710802	56710803	56710804	56710805	56710806	56710808	56710810
10.000 kg	Art.No. 56711002	56711003	56711004	56711005	56711006	56711008	56711010

GÖZLÜ SAPAN - KAPASİTESİ TABLOSU (kg)					
Renk kodu	Düz kaldırma	Boğma	U kaldırma	Açılı kaldırma	
				0° - 45°	45° - 60°
	500	400	1000	700	500
	1000	800	2000	1400	1000
	2000	1600	4000	2800	2000
	3000	2400	6000	4200	3000
	4000	3200	8000	5600	4000
	5000	4000	10000	7000	5000
	6000	4800	12000	8400	6000
	8000	6400	16000	11200	8000
	10000	8000	20000	14000	10000

Emniyet faktörü: 7:1
Safety factor: 7:1

* Farklı ölçüler için satış temsilcilerimizle irtibata geçiniz.

* Please contact our sales department for different capacities.

- Ağır hizmet polyester bant
- Dayanıklı ve uzun ömürlü göz koruyucuları
- Uluslararası renk kodları
- Optimize edilmiş esneklik
- Yüksek emniyet katsayısı

- Heavy duty polyester band
- High stability and long life eye protectors
- International color codes
- Optimized flexibility
- High rated safety coefficient

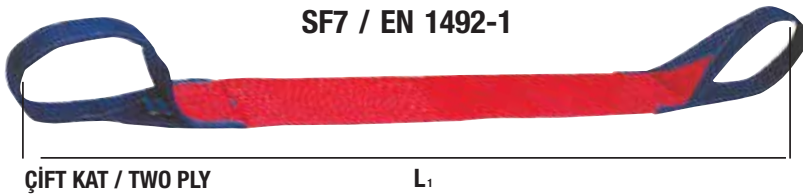

TEK KULLANIMLIK POLYESTER SONSUZ BANT (SF 1:5) / ONE USE WEBBING SLING (SF 1:5)



Tek kullanımlık dokuma sonsuz sapanlar DIN 60005'e göre üretilmektedir ve 1:5 emniyet faktörüne sahiptirler. Bu yük taşıma kapasitesi 1 ton olan bir sapanın kopma mukavemetinin 5 ton olması gerektiği anlamına gelir. Taşıma zincirinin sonunda tekrar kullanılmayıp atılmaları gereklidir. Tek kullanımlık veya atılabilir dokuma sapanlar pratik uygulamalarda değişik renklerde dokuma sonsuz sapan veya gözlü sapan gibi çok farklı tasarımlara sahip olabilirler.

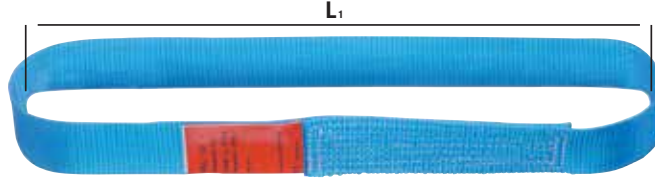

Art.No.	Kaldırma Kapasitesi WLL (t)	Bant uzunlukları L1 (m)
15411517	1.5	1.50
15411516	1.5	1
15411015	1	1.5
15411010	1	1
15412075	2	0.75
15412090	2	0.90
15412018	2	1.80

Fiyatlar stoktaki ürünler için geçerlidir.

GERDİRMELER / CARGO LASHINGS

Kapasitesi / Capacity	NL-35-4			NL-35-6			NL-35-8			NL-50-8			NL-50-10			NL-50-12			daN
	1000/ 2000						2000/ 4000												
Bant genişliği / Band width	35	35	35	50	50	50	50	50	50	50	50	50	50	50	50	50	50	50	mm
Uzunluk / Length	4	6	8	8	10	12	8	10	12	8	10	12	8	10	12	8	10	12	m

Art.No. 52000109	NL-35-4
Art.No. 52000110	NL-35-6
Art.No. 52000111	NL-35-8
Art.No. 52000112	NL-50-8
Art.No. 52000113	NL-50-10
Art.No. 52000114	NL-50-12

- Uzun ömürlü
- Sağlam mekanizma
- Farklı bant genişliği ve farklı kanca çeşitleri
- Tüm gerdirmeler PES, DIN 60060 VDI 2700, 2701, 2702 prEN 12195-2 standartlarında üretilmiştir.
- Yukarıda verilen uzunluklar standart uzunluklardır. Ancak isteğinize bağlı olarak uzunluklar için bizimle iletişime geçiniz.
- Opsiyonel olarak mekanizma ve kancalar paslanmaz çelikten imal edilebilir.



- Long life-time
- Robust mechanism
- Different band width and hook types
- All ratchet tie downs has manufactured acc. PES, DIN 60060 VDI 2700, 2701, 2702 prEN 12195-2 standards.
- All above mentioned lengths are standard but any other length is possible.
- Ratchet and the hooks can be delivered in stainless steel version as option.

MINİ GERDİRMELER / CARGO TIE DOWN

Boy / Length	NL- TDR 101-S		NL- TDRPS	
	4	5	5	5
Kapasite / Capacity	400	180	180	180
Kanca / Hook	S Kanca / S hook	Metal birleştirici/ Metal plates	Metal birleştirici/ Metal plates	Metal plates



Art.No. 52000106	NL- TDR 101-S
Art.No. 52000107	NL- TDRPS



Parke sıkma / Architectural tool

NL- TDRPS

ZİNCİR GERGİ MEKANİZMASI - ÇATAL + ÇATAL

Art.No	9380 16 01	9380 16 02	9380 16 03	9380 16 04	9380 16 05	
Zincir ölçüsü / Chain size	6	8	10	13	16	mm
Gerdirme kuvveti / Tensile strength	2200	4000	6300	10000	16000	daN
Kopma yükü / Breaking load	45.20	80.40	126.00	212.00	322.00	kN
Ayar aralığı (l) min./max / Adjustment range	230 - 320	330 - 470	460 - 670	520 - 770	540 - 790	mm
Gerdirme uzunluğu / Stretching length	90	140	220	250	250	mm
Kg / Weight	100	200	400	670	950	%

Malzeme : Yüksek mukavemetli alaşım çelik, Grade 80
Standart : DIN EN 1677-1 'e göre üretici sertifikası
DIN EN 12195-3' e göre sertifikalandırılmıştır.

Material : High tensile alloyed steel, Grade 8
Standard : Acc.to DIN EN 1677-1 and
DIN EN 12195-3

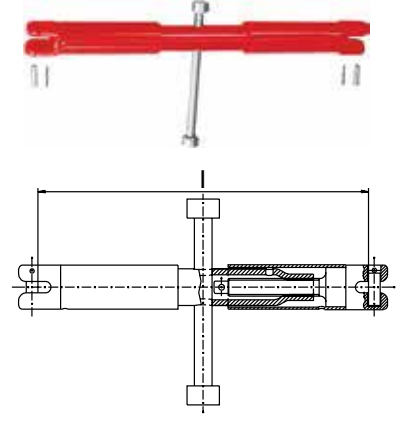

ZİNCİR GERGİ MEKANİZMASI - GÖZ + GÖZ

Art.No	9380 18 01	9380 18 02	9380 18 03	9380 18 04	9380 18 05	
Zincir ölçüsü / Chain size	6	8	10	13	16	mm
Gerdirme kuvveti / Tensile strength	2200	4000	6300	10000	16000	daN
Kopma yükü / Breaking load	45.20	80.40	126.00	212.00	322.00	kN
Ayar aralığı (l) min./max / Adjustment range	412 - 502	588 - 738	630 - 780	722 - 872	784 - 914	mm
Gerdirme uzunluğu / Stretching length	90	150	150	150	130	mm
Kg / Weight	171	455	575	858	1334	%

Malzeme : Yüksek mukavemetli alaşım çelik, Grade 80
Standart : DIN EN 1677-1 'e göre üretici sertifikası
DIN EN 12195-3' e göre sertifikalandırılmıştır.

Material : High tensile alloyed steel, Grade 8
Standard : Acc.to DIN EN 1677-1 and
DIN EN 12195-3

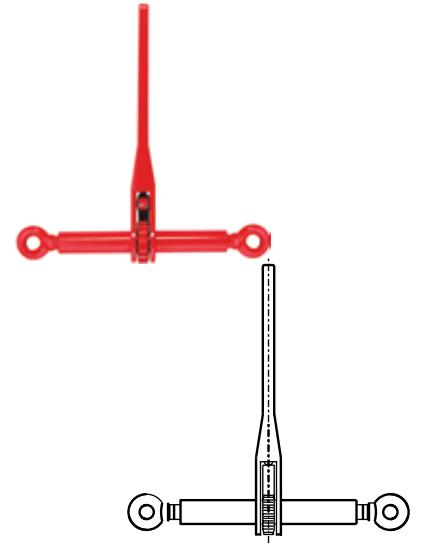

ZİNCİR GERGİ MEKANİZMASI - KANCA + KANCA

Art.No	9380 18 11	9380 18 12	9380 18 13	9380 18 14	9380 18 15	
Zincir ölçüsü / Chain size	6	8	10	13	16	mm
Gerdirme kuvveti / Tensile strength	2200	4000	6300	10000	16000	daN
Kopma yükü / Breaking load	45.20	80.40	126.00	212.00	322.00	kN
Ayar aralığı (l) min./max / Adjustment range	232 - 322	360 - 510	360 - 510	366 - 516	390 - 520	mm
Gerdirme uzunluğu / Stretching length	90	150	150	150	130	mm
Kg / Weight	117	340	340	400	670	%

Malzeme : Yüksek mukavemetli alaşım çelik, Grade 80
Standart : DIN EN 1677-1 'e göre üretici sertifikası
DIN EN 12195-3' e göre sertifikalandırılmıştır.

Material : High tensile alloyed steel, Grade 8
Standard : Acc.to DIN EN 1677-1 and
DIN EN 12195-3

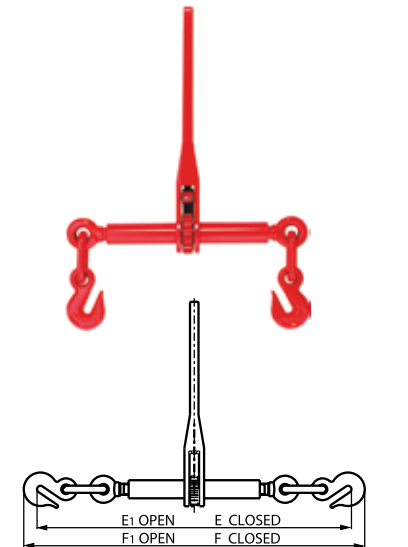

KISALTMA KANCASIZ WITHOUT SHORTENING HOOK GRADE 8

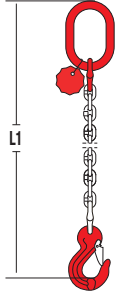

TEK BACAĞLI ZİNCİR SAPAN /
ONE LEGGED CHAIN SLING



W.L.L (kg)	Zincir Çapı Chain dia (mm)	Kod No Code no	Kod No Code no	Kod No Code no
1120	6	58910001	58910011	58910021
2000	8	58910003	58910013	58910023
3150	10	58910004	58910014	58910024
5300	13	58910005	58910015	58910025
8000	16	58910006	58910016	58910026

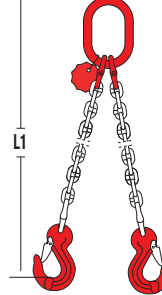

İKİ BACAĞLI ZİNCİR SAPAN /
TWO LEGGED CHAIN SLING



W.L.L (kg) 0 - 45°	W.L.L (kg) 45 - 60°	Zincir Çapı Chain dia (mm)	Kod No Code no	Kod No Code no	Kod No Code no
1600	1120	6	58910031	58910041	58910051
2800	2000	8	58910033	58910043	58910053
4250	3150	10	58910034	58910044	58910054
7500	5300	13	58910035	58910045	58910055
11200	8000	16	58910036	58910046	58910056

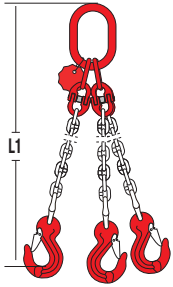

ÜÇ BACAĞLI ZİNCİR SAPAN /
THREE LEGGED CHAIN SLING



W.L.L (kg) 0 - 45°	W.L.L (kg) 45 - 60°	Zincir Çapı Chain dia (mm)	Kod No Code no	Kod No Code no	Kod No Code no
2360	1700	6	58910061	58910071	58910081
4250	3000	8	58910063	58910073	58910083
6700	4750	10	58910064	58910074	58910084
11200	8000	13	58910065	58910075	58910085
17000	11800	16	58910066	58910076	58910086

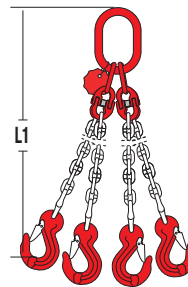

DÖRT BACAĞLI ZİNCİR SAPAN /
FOUR LEGGED CHAIN SLING



W.L.L (kg) 0 - 45°	W.L.L (kg) 45 - 60°	Zincir Çapı Chain dia (mm)	Kod No Code no	Kod No Code no	Kod No Code no
2360	1700	6	58910091	58910101	58910111
4250	3000	8	58910093	58910103	58910113
6700	4750	10	58910094	58910104	58910114
11200	8000	13	58910095	58910105	58910115
17000	11800	16	58910096	58910106	58910116

ZİNCİR SAPAN KULLANIMINDA DİKKAT EDİLMESİ GEREKEN HUSUSLAR

Zincirlerin ve zincir sapanların, sürekli kullanımda ortaya çıkacak aşınmalara ve hasarlara karşı düzenli aralıklarla kontrol edilmesi, emniyetli kullanım için uygun olup olmadığının tespiti için gereklidir.

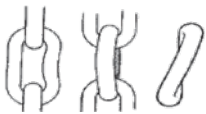

DEFORMASYON :

Eğilmiş, bükülmüş, aşırı sıcak nedeniyle deforme olmuş / korozyona uğramış zincirler derhal kullanımdan kaldırılmalıdır.



ÇATLAMALAR

Çatlama gösteren zincirler derhal atılmalıdır. Enine çatlamlar en ciddi durumdur.



TANIMLAMA ETİKETİ :

Üzerinde tanımlama etiketi bulunmayan zincir sapanlar kullanılmamalıdır.



KAYNAK

Üzerinde kaynak lemi yapılmış zincirler kullanılmamalıdır.

KISALTMA KANCALI WITH SHORTENING HOOK GRADE 8



**KISALTMA KANCALI TEK BACAĞLI
ZİNCİR SAPAN**
WITH SHORTENING HOOK ONE LEGGED CHAIN SLING



W.L.L (kg)	Zincir Çapı Chain dia (mm)	Kod No Code no	Kod No Code no	Kod No Code no
1120	6	58910121	58910131	58910141
2000	8	58910123	58910133	58910143
3150	10	58910124	58910134	58910144
5300	13	58910125	58910135	58910145
8000	16	58910126	58910136	58910146

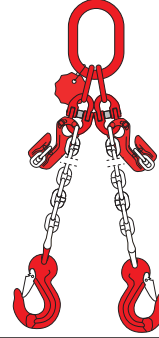

**KISALTMA KANCALI İKİ BACAĞLI
ZİNCİR SAPAN**
WITH SHORTENING HOOK TWO LEGGED CHAIN SLING



W.L.L (kg)	W.L.L (kg)	Zincir Çapı Chain dia (mm)	Kod No Code no	Kod No Code no	Kod No Code no
0 - 45°	45 - 60°				
1600	1120	6	58910151	58910161	58910171
2800	2000	8	58910153	58910163	58910173
4250	3150	10	58910154	58910164	58910174
7500	5300	13	58910155	58910165	58910175
11200	8000	16	58910156	58910166	58910176

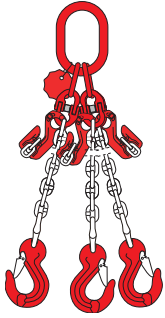

**KISALTMA KANCALI ÜÇ BACAĞLI
ZİNCİR SAPAN**
WITH SHORTENING HOOK THREE LEGGED CHAIN SLING



W.L.L (kg)	W.L.L (kg)	Zincir Çapı Chain dia (mm)	Kod No Code no	Kod No Code no	Kod No Code no
0 - 45°	45 - 60°				
2360	1700	6	58910181	58910191	58910201
4250	3000	8	58910183	58910193	58910203
6700	4750	10	58910184	58910194	58910204
11200	8000	13	58910185	58910195	58910205
17000	11800	16	58910186	58910196	58910206

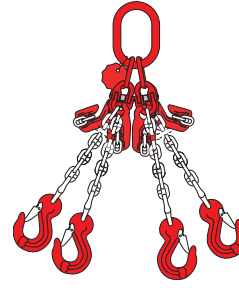

KISALTMA KANCALI DÖRT BACAĞLI ZİNCİR SAPAN
WITH SHORTENING HOOK FOUR LEGGED CHAIN SLING



W.L.L (kg)	W.L.L (kg)	Zincir Çapı Chain dia (mm)	Kod No Code no	Kod No Code no	Kod No Code no
0 - 45°	45 - 60°				
2360	1700	6	58910211	58910221	58910231
4250	3000	8	58910213	58910223	58910233
6700	4750	10	58910214	58910224	58910234
11200	8000	13	58910215	58910225	58910235
17000	11800	16	58910216	58910226	58910236

ZİNCİR SAPAN KULLANIMINDA DİKKAT EDİLMESİ GEREKEN HUSUSLAR

Kanca ve mapaların , sürekli kullanımda ortaya çıkacak aşınmalara ve hasarlara karşı düzenli aralıklarla kontrol edilmesi, emniyetli kullanım için uygun olup olmadığının tespiti için gereklidir.



Güvenlik mandallı kancalarda, güvenlik mandalı fonksiyonunu kaybetmişse kullanımdan çıkarılmalıdır.



Kancanın yük merkezindeki aşınma oranı %10 seviyesini aşmamalıdır.



Eğilme, bükülme durumunda kanca kullanımdan çıkarılmalıdır. Kimi kaynaklar 10° ye kadar olan eğilme ve bükülmeleri tolere edebilmektedir.

Periyodik kontroller dışında, her kullanım öncesi kullanıcı kontrolü yapılmalıdır !

KAPASİTE TABLOSU / CAPACITY CHART GRADE 8

Zincir çapı Chain Dia mm	İzin verilen kapasiteler / Permitted load-bearing capacity in t for:											
	Tek Bacak Single leg			İki Bacak Two leg		3 ve 4 Bacak 3 and 4-leg		Tek Bacak Basket Single leg Basket Sling		İki Bacak Basket Two leg Basket sling		Sonsuz Sapan Boğma Endless sling in choke
Kaldırma Açısı Angle of inclination β	0°	0° - 45°	45° - 60°	0° - 45°	45° - 60°	0° - 45°	45° - 60°	0° - 45°	45° - 60°	0° - 45°	45° - 60°	
6	1,12	1,6	1,12	2,36	1,7	1,18	0,85	1,9	1,32			1,8
8	2	2,8	2	4,25	3	2,12	1,6	3,35	2,36			3,15
10	3,15	4,25	3,15	6,7	4,75	3,35	2,5	5,3	3,75			5
13	5,3	7,5	5,3	11	8	5,6	4	9	6,3			8,5
16	8	11,2	8	17	11,8	8,5	6,3	13,2	9,5			12,5

ZİNCİR / CHAIN GRADE 8

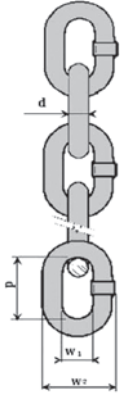

Model	Kod No Art. No.	Boyutlar / Dimensions (mm)				
		Zincir Çapı Chain size d	İç bakla uzunluğu Pitch p	Genişlik Width w 1min.	Genişlik Width w 2 max	Ağırlık Weight kg / m
NL-C 06	58900006	6	18	7,8	22,5	0,8
NL-C 08	58900008	8	24	10,4	29,6	1,4
NL-C 10	58900010	10	30	13,0	37,0	2,2
NL-C 13	58900013	13	39	16,9	48,1	3,8
NL-C 16	58900016	16	48	20,8	59,2	5,7

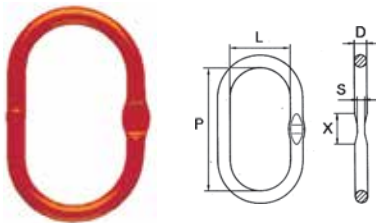

ANA BAĞLANTI HALKASI / MASTERLINK

GRADE 8

Kod No Art. No.	Model	Zincir / Chain		W.L.L. kg	Boyutlar / Dimensions mm				Ağırlık / Weight kg
		Ø mm	Ø mm		D	P	L	SxX	
58900106	NL-CM 06	7	6	1600	13	110	60	8x25	0.34
58900107	NL-CM 08	8	7	2120	16	110	60	8x25	0.53
58900108	NL-CM 10	10	8	3150	18	135	75	8x25	0.915
58900110	NL-CM 13	13	10	5300	22	160	90	11.3x35	1.60
58900113	NL-CM 16	16	13	8000	26	180	100	14x46	2.46
58900116	NL-CM 18	18	16	11200	32	200	110		

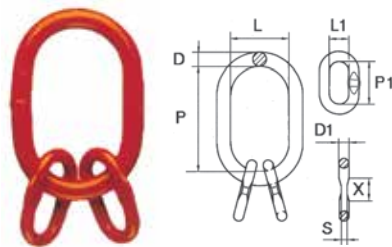

ANA BAĞLANTI HALKASI / MASTERLINK WITH SUBLINKS

GRADE 8

Kod No Art. No.	Model	Zincir / Chain Ø mm	W.L.L. kg	Boyutlar / Dimensions mm								Ağırlık / Weight kg
				D	P	L	D1	P1	L1	SxX		
58900206	NL-CMC 06	6	2360	18	135	75	13	54	25	8x25	1.315	
58900208	NL-CMC 08	8	4250	22	160	90	16	70	34	8x25	2.32	
58900210	NL-CMC 10	10	6700	26	180	100	18	85	40	11.3x35	3.52	
58900213	NL-CMC 13	13	11200	32	200	110	22	115	50	14x46	6.26	
58900216	NL-CMC 16	16	17000	36	260	140	26	140	65	18x46	9.56	

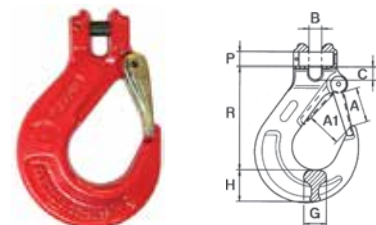

EMNİYET MANDALLI KANCA / CLEVIS HOOK WITH LATCH

GRADE 8

Kod No Art. No.	Model	Zincir / Chain		W.L.L. kg	Boyutlar / Dimensions mm								Ağırlık / Weight kg
		mm	inch		A	A1	B	C	G	H	P	R	
58900906	NL-CB 06	6	1/4	1120	25	19	6,7	8,5	14,5	20	7	73	0,24
58900908	NL-CB 08	8	5/16	2000	29,5	24,5	8,7	9,8	19	27	9	86,3	0,53
58900910	NL-CB 10	10	3/8	3150	35,7	29	12,2	13,5	23,5	33	13	105	0,95
58900913	NL-CB 13	13	1/2	5300	43,5	35	15,3	17	28,5	40	16	128,5	1,67
58900916	NL-CB 16	16	5/8	8000	56	45	18	22	37	48	20	155	3,00

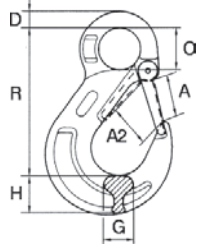
**EMNİYET MANDALLI KUŞ GÖZLÜ KANCA / SLING HOOK WITH LATCH****GRADE 8**

Kod No Art No.	Model	Zincir / Chain		W.L.L. kg	Boyutlar / Dimensions mm						Ağırlık / Weigh kg	
		mm	inch		A	A2	D	G	H	O		R
58900606	NL-CA 06	6	1/4	1120	25	20,5	8,5	14,5	20	20,5	80,5	0,27
58900608	NL-CA 08	8	5/16	2000	29,5	24,5	11	19	27	25	95,5	0,50
58900610	NL-CA 10	10	3/8	3150	35,7	29	14	23,5	33	34	120,5	0,90
58900613	NL-CA 13	13	1/2	5300	43,5	35,4	17,5	29	40	42,5	150	1,50
58900616	NL-CA 16	16	5/8	8000	52,5	44	22	35,5	49	52	183	2,75

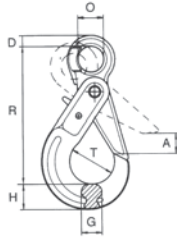
**GÖVDE MANDALLI KUŞ GÖZLÜ KANCA / SELF LOCKING EYE HOOK****GRADE 8**

Kod No Art No.	Model	Zincir / Chain		W.L.L. kg	Boyutlar / Dimensions mm						Ağırlık / Weigh kg	
		mm	inch		A	D	G	H	O	R		T
58900806	NL-CRO 06	6	1/4	1120	28	11	16	21	21	109	35	0,510
58900808	NL-CRO 08	8	5/16	2000	34	12	20	26	25	135	43	0,936
58900810	NL-CRO 10	10	3/8	3150	45	16	25	30	33	168	56	1,626
58900813	NL-CRO 13	13	1/2	5300	51	20	35	40	40	205	69	3,250
58900816	NL-CRO 16	16	5/8	8000	60	27	36	50	50	251	80	6,050

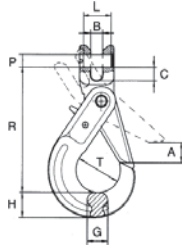
**GÖVDE MANDALLI KANCA / SELF LOCKING CLEVIS HOOK****GRADE 8**

Kod No Art No.	Model	Zincir / Chain		W.L.L. kg	Boyutlar / Dimensions mm								Ağırlık / Weigh kg
		mm	inch		A	B	C	G	H	R	T	PxL	
58900706	NL-CRF 06	6	1/4	1120	28	7	8	16	21	94	35	7,5x17,5	0,496
58900708	NL-CRF 08	8	5/16	2000	34	9	10	20	26	123	43	9x22,5	0,934
58900710	NL-CRF 10	10	3/8	3150	45	12	14	25	30	143	56	13,31,5	1,580
58900713	NL-CRF 13	13	1/2	5300	51	15	17	35	40	180	69	16x42	3,200
58900716	NL-CRF 16	16	5/8	8000	60	19	19	36	50	215	80	21x51x5	5,950

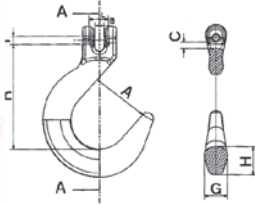
**GENİŞ AĞIZLI KANCA / FOUNDRY CLEVIS HOOK****GRADE 8**

Kod No Art No.	Model	Zincir / Chain		W.L.L. kg	Boyutlar / Dimensions mm						Ağırlık / Weigh kg	
		mm	inch		A	B	C	G	H	R		PxL
58901306	NL-CYF 06	6	1/4	1120	53,5	8,5	6,5	22	26	91	7,5x17,5	0,7
58901308	NL-CYF 08	8	5/16	2000	64	10	11,5	26	31	120,4	9x22,5	1,1
58901310	NL-CYF 10	10	3/8	3150	76	13	15	30	34	131	13x31,5	1,7
58901313	NL-CYF 13	13	1/2	5300	89	17	17,5	40	44,5	148	16x42	3,6
58901316	NL-CYF 16	16	5/8	8000	101	19	21,5	45	50,5	198,5	21x51,5	5,6

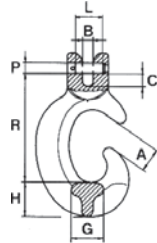
**CT KANCA / CLEVIS GRAB HOOK****GRADE 8**

Kod No Art No.	Model	Zincir / Chain		W.L.L. kg	Boyutlar / Dimensions mm						Ağırlık / Weigh kg	
		mm	inch		A	B	C	G	H	R		PxL
58900508	NL-CT 08	8	5/16	2000	20	9	11	22	27	90	9x22,5	0,56
58900510	NL-CT 10	10	3/8	3150	28	12	14	28	39	129	13x31,5	1,40
58900513	NL-CT 13	13	1/2	5300	39	15	17	35	51	166	16x42	3,00

**GÖVDE MANDALLI KULPLU KANCA / CLEVIS GRIP SAFE LOCKING HOOK****GRADE 100**

Kod No Art No.	Model	Zincir / Chain		W.L.L. kg	Boyutlar / Dimensions mm						Ağırlık / Weigh kg	
		mm	inch		A	H	K	O	P	T		W
57901710	NL-SLX 10	10		4000	11	31	153	49	71	27	139	1,9
57901713	NL-SLX 13	13		6700	14	39	206	57	80	34	174	4,1
57901716	NL-SLX 16	16		10000	18	47	243	78	114	39	212	6,4
57901720	NL-SLX 20	20		16000	21	56	310	91	127	54	250	12,7
57901722	NL-SLX 22	22		19000	24	59	300	105	151	56	260	14,1

KISALTIMA KANCASI / CLEVIS GRAB HOOK

GRADE 8

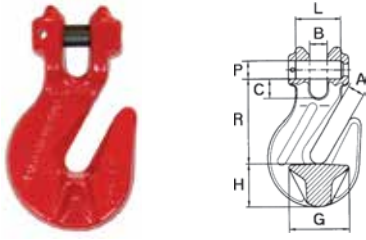

Kod No Art No.	Model	Zincir / Chain		W.L.L. kg	Boyutlar / Dimensions mm								Ağırlık / Weight kg
		mm	inch		A	B	C	G	H	R	PxL		
58901506	NL-CF 06	6	1/4	1120	8	8	8.8	22	22	50.5	7.5x17.5	0.20	
58901508	NL-CF 08	8	5/16	2000	10	9	10	30	24	50	9x22.5	0.27	
58901510	NL-CF 10	10	3/8	3150	13	13	14	44	31	72	13x31.5	0.75	
58901513	NL-CF 13	13	1/2	5300	17	17	17	53	38	88	16x42	1.35	
58901516	NL-CF 16	16	5/8	8000	20	21	20	64	60	111	21x51.5	2.8	

KISALTIMA APARATI / SHORTENING CLUTCH

GRADE 8

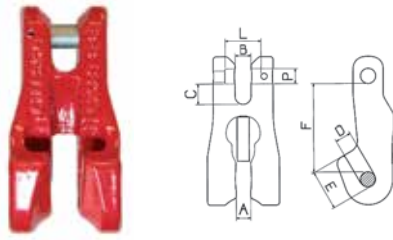

Kod No Art No.	Model	Zincir / Chain		W.L.L. kg	Boyutlar / Dimensions mm								Ağırlık / Weight kg
		mm	inch		A	B	C	D	E	F	PxL		
58900306	NL-CX 06	6	1/4	1120	8	8	10	8	19	45	7.5x17.5	0.21	
58900308	NL-CX 08	8	5/16	2000	9.5	9.5	10	9.5	23.5	56	10x22.5	0.48	
58900310	NL-CX 10	10	3/8	3150	12	12	14.5	12	32.5	78	13x31.5	1.12	
58900313	NL-CX 13	13	1/2	5300	15.5	15.5	18	15.5	44	90	16x42	1.83	
58900316	NL-CX 16	16	5/8	8000	19	21	21	19	50	106	21x51.5	2.83	

BAĞLANTI ELEMANI / COUPLING LINK

GRADE 8

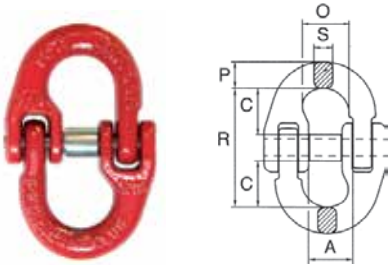

Kod No Art No.	Model	Zincir / Chain		W.L.L. kg	Boyutlar / Dimensions mm							Ağırlık / Weight kg
		mm	inch		A	C	O	R	P	S		
58900406	NL-CL 06	6	1/4	1120	16	18	16.5	43	7.2	6.8	0.07	
58900408	NL-CL 08	8	5/16	2000	19	25.5	23.5	62	11.5	10	0.25	
58900410	NL-CL 10	10	3/8	3150	23.8	30	27.5	72	12.6	12.6	0.35	
58900413	NL-CL 13	13	1/2	5300	28	36	33.3	87.3	19	16.7	0.68	
58900416	NL-CL 16	16	5/8	8000	34.3	40.5	39.5	103	20.6	20.6	1.10	

POLYESTER SAPAN BAĞLANTI ELEMANI / WEBBING COUPLING LINK

GRADE 8

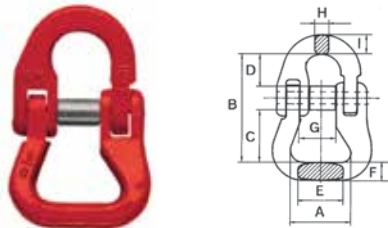

Kod No Art No.	Model	Zincir / Chain		W.L.L. kg	Boyutlar / Dimensions mm									Ağırlık / Weight kg
		mm	inch		A	B	C	D	E	F	G	H	I	
58901408	NL-CLS 08	8	5/16	2000	40	58	24	20	24	14	17	9	10	0.28
58901410	NL-CLS 10	10	3/8	3150	40	81	35	30	30	14	23	11	13	0.47
58901413	NL-CLS 13	13	1/2	5300	55	104	48	36	36	18	28	16	16	0.99
58901416	NL-CLS 16	16	5/8	8000	67	115	57	40	44	24	36	21	21	2.0

POLYESTER SAPAN KANCASI / HOOK FOR WEB SLING

GRADE 8

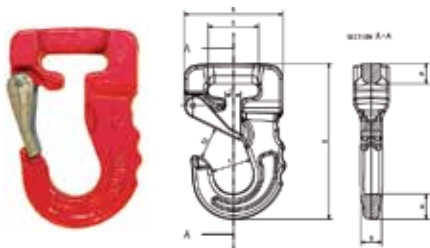

Kod No Art No.	Model	W.L.L. kg	Boyutlar / Dimensions mm									Ağırlık / Weight kg
			A	B	C	D	G	H	P	T	T2	
58900301	NL-CJ 01	1000	78	123	12	41	17	20	16	31	26	0.7
58900302	NL-CJ 02	2000	91	148	19	55	21	26	17	40	31	1.2
58900303	NL-CJ 03	3000	113	175	21	55	25	32	25	50	37	2.2
58900304	NL-CJ 04	4000	133	223	40	70	36	40	36	59.5	43	4.5
58900305	NL-CJ 05	5000	133	223	40	70	36	40	36	59.5	43	4.5
58902306	NL-CJ 06	6000	133	223	40	70	36	40	36	59.5	43	4.5
58902308	NL-CJ 08	8000	188	302	50	105	40	60	42	80	65	9.7
58902310	NL-CJ 10	10000	188	302	50	105	40	60	42	80	65	9.7

**EMNİYET MANDALLI KANCA KİTİ /
LATCH KIT FOR HOOKS**



Kod No Art No.	Model	Zincir / Chain	
		mm	inch
Y109201010	NL-CKS 06	6	1/4
Y109201011	NL-CKS 08	8	5/16
Y109201012	NL-CKS 10	10	3/8
Y109201013	NL-CKS 13	13	1/2
Y109201014	NL-CKS 16	16	5/8

**GÖVDE MANDALLI KANCA KİTİ /
LOCKING SYSTEM KIT FOR
SELF LOCKING HOOKS**



Kod No Art No.	Model	Zincir / Chain	
		mm	inch
Y109201015	NL-CKSL 06	6	1/4
Y109201016	NL-CKSL 08	8	5/16
Y109201017	NL-CKSL 10	10	3/8
Y109201018	NL-CKSL 13	13	1/2
Y109201019	NL-CKSL 16	16	5/8

FIRDÖNDÜLÜ BAĞLANTI NOKTASI / ROTATING EYEBOLT WITH RING

GRADE 8

KAPASİTE TABLOSU / CAPACITY TABLE

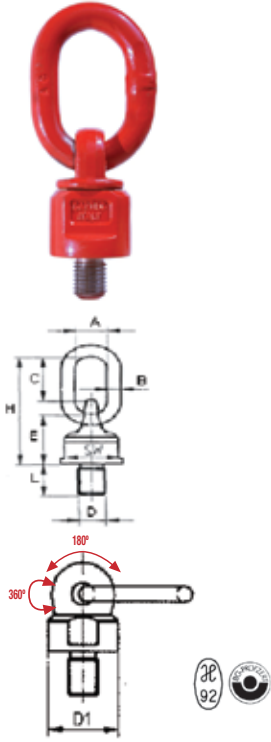

Kod No Art No.	Ölçü/Size mm	W.L.L. † G	mm							Ağırlık / Weight kg	KAPASİTE TABLOSU / CAPACITY TABLE											
			A	B	C	E	H	SW	D1		0° Tek Bacak	0° İki Bacak	90° Tek Bacak	90° İki Bacak	0-45° İki Bacak	45-60° Asimm	0-45° İki Bacak	45-60° 3-4 Bacak	Asimm	Nm		
39500030	M10x18	0,3	30	13	46	50	105	30	38	0,480	0,6	1,2	0,3	0,6	0,42	0,3	0,3	0,63	0,45	0,3	16	
39500050	M12x18	0,5	30	13	46	50	105	30	38	0,500	1	2	0,5	1	0,75	0,5	0,5	1,1	0,75	0,5	28	
39500052	M12x25	0,5	30	13	46	50	105	30	38	0,500	1	2	0,5	1	0,75	0,5	0,5	1,1	0,75	0,5	28	
39500125	M16x20	1,12	30	13	46	50	105	30	38	0,530	2	4	1,12	2	1,5	1,12	1,12	2,36	1,6	1,12	70	
39500126	M16x30	1,12	30	13	46	50	105	30	38	0,530	2	4	1,12	2	1,5	1,12	1,12	2,36	1,6	1,12	70	
39500150	M20x30	1,12	30	13	46	50	105	30	38	0,530	2	4	1,12	2	1,5	1,12	1,12	2,36	1,6	1,12	135	
39500200	M20x30	2	34	16	57	61	131	40	50	1,050	4	8	2	4	2,8	2	2	4	3	2	135	
39500300	M24x30	3,15	40	19	70	68	153	48	58	1,630	6,3	12,5	3,15	6,3	4,25	3,15	3,15	6,3	4,75	3,15	230	
39500500	M30x35	5,3	40	20	65	80	165	65	75	2,230	10,6	21,2	5,3	10,6	7,1	5,3	5,3	11,2	8	5,3	465	
39500502	M30x45	5,3	40	20	65	80	165	65	75	2,230	10,6	21,2	5,3	10,6	7,1	5,3	5,3	11,2	8	5,3	465	
39500800	M30x35	8	50	22	90	95	205	75	85	5,300	12,5	25	8	16	11,2	8	8	16,8	12	8	465	
39500801	M30x45	8	50	22	90	95	205	75	85	5,300	12,5	25	8	16	11,2	8	8	16,8	12	8	465	
39500802	M36x54	8	50	22	90	95	205	75	85	5,500	12,5	25	8	16	11,2	8	8	16,8	12	8	814	
39501042	M42x63	10	50	22	90	95	205	75	85	10,000	15	30	10	20	14	10	10	21,2	15	10	1304	
39501501	M48x60	15	70	30	120	130	280	95	120	10,000	25	50	15	30	21	15	15	31,5	22,5	15	1981	
39501556	M56x78	15	70	30	120	130	280	95	120	10,000	25	50	15	30	21	15	15	31,5	2,5	15	3000	
39501564	M64x96	15	70	30	120	130	280	95	120	10,000	25	50	15	30	21	15	15	31,5	22,5	15	4738	
39501572	M72x108	25	68	40	127	165	338	134	160	29,000	35	70	25	50	35	25	25	52,5	37,5	25	6913	
39501580	M80x120	30	68	40	127	165	338	134	170	29,000	35	70	30	60	42	30	30	63	45	30	9625	
39501590	M90x135	35	68	40	127	165	338	134	170	29,000	35	70	35	70	49	35	35	73,5	52,5	35	14000	

BAĞLANTI NOKTASI / EYEBOLT

GRADE 8

KAPASİTE TABLOSU / CAPACITY TABLE

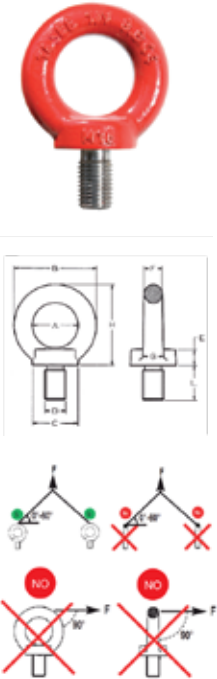

Kod No Art No.	Ölçü/Size (DxL)mm	W.L.L. † G	mm							Ağırlık / Weight kg	KAPASİTE TABLOSU / CAPACITY TABLE					
			A	B	C	E	F	H	0° Tek Bacak		0° İki Bacak	0-45° İki Bacak	45-60° Asimm	0-45° İki Bacak	45-60° 3-4 Bacak	Nm
29570006	M6x13	0,4	25	45	25	10	10	45	0,090	0,4	0,8	0,14	0,1	0,2	0,14	3,5
29570008	M8x13	0,8	25	45	25	10	10	45	0,090	0,8	1,6	0,25	0,2	0,4	0,28	8
29570010	M10x17	1	25	45	25	10	10	45	0,110	1	2	0,35	0,25	0,5	0,35	16
29570012	M12x21	1,6	35	63	35	14	14	62	0,270	1,6	3,2	0,56	0,4	0,8	0,56	28
29570014	M14x21	3	35	63	35	14	14	62	0,290	3	6	1	0,75	1,5	1	45
29570016	M16x27	4	35	63	35	14	14	62	0,310	4	8	1,4	1	2	1,4	70
29570018	M18x27	5	50	90	50	20	20	90	0,840	5	10	1,8	1,25	2,5	1,8	95
29570020	M20x30	6	50	90	50	20	20	90	0,860	6	12	2,1	1,5	3	2,1	135
29570022	M22x36	7	50	90	50	20	20	90	0,900	7	14	2,4	1,75	3,5	2,4	182
29570024	M24x36	8	50	90	50	20	20	90	0,900	8	16	2,8	2	4	2,8	230
29570027	M27x45	10	60	108	65	24	24	109	1,660	10	20	3,5	2,5	5	3,5	343
29570030	M30x45	12	60	108	65	24	24	109	1,700	12	24	4,2	3	6	4,2	465
29570033	M33x54	14	70	126	75	26	28	128	2,000	14	28	4,8	3,4	6,8	4,8	632
29570036	M36x54	16	70	126	75	26	28	128	2,150	16	32	5,6	3,9	7,8	5,4	814
29570042	M42x63	24	80	144	85	30	32	147	4,150	24	48	8,4	5,9	11,8	8,2	1304
29570048	M48x68	32	90	166	100	35	38	168	6,200	32	64	11,2	7,8	15,6	10,9	1981
29570056	M56x78	36	100	184	110	38	42	187	8,800	36	72	12,6	8,8	17,6	12,3	3000
29570064	M64x90	45	110	206	120	42	48	208	12,400	45	90	15,7	11	22	15,4	4736

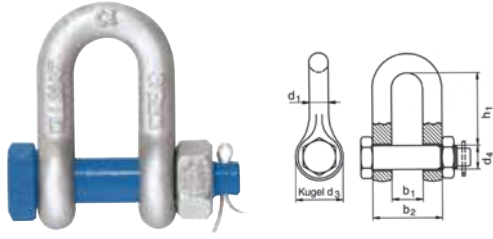

EMNİYET SOMUNLU U MAPALAR / SHACKLE HIGH TENSILE U FORM LOCK NUT

Kod No Art No.	Ölçü / Dimension ns	W.L.L. t	Ölçüler / Dimensions mm							Ağırlık / Weight kg
			b1	b2	d1	d4	h1	d3		
25541005	1/4"	0,500	12	26	6	8	22	17	0,06	
25541007	5/16"	0,750	13	29	8	10	26	21	0,10	
25541010	3/8"	1,000	16	36	10	12	31	26	0,15	
25541015	7/16"	1,500	18	40	11	14	36	28	0,22	
25541020	1/2"	2,000	21	47	13	16	41	30	0,34	
25541032	5/8"	3,250	27	59	16	19	51	42	0,70	
25541047	3/4"	4,750	32	70	19	22	60	48	1,18	
25541065	7/8"	6,500	36	80	22	25	71	57	1,64	
25541085	1"	8,500	43	93	25	28	81	62	2,41	
25541095	1 1/8"	9,500	46	104	29	32	90	69	3,27	
25541120	1 1/4"	12,000	52	116	32	35	100	78	4,59	
25541135	1 3/8"	13,500	57	127	35	38	113	86	6,00	
25541170	1 1/2"	17,000	60	136	38	42	124	94	8,33	
25541250	1 3/4"	25,000	73	161	44	50	146	112	12,83	
25541350	2"	35,000	83	185	51	55	171	127	19,30	
25541500	2 1/2"	55,000	105	232	64	70	203	152	34,50	
25541851	3"	85,000	127	279	76	82	216	200	60,00	
25541121	3 1/2"	120,000	133	317	89	95	253	203	93,00	
25541151	4"	150,000	140	348	102	107	250	226	145,00	

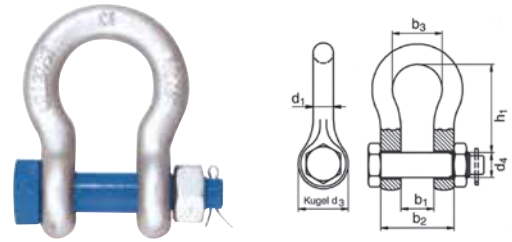

EMNİYET SOMUNLU OMEGA MAPALAR / SHACKLE HIGH TENSILE OMEGA FORM LOCK NUT

Kod No Art No.	Ölçü / Dimension ns	W.L.L. t	Ölçüler / Dimensions mm							Ağırlık / Weight kg
			b1	b2	b3	d1	d3	d4	h1	
25543005	1/4"	0,500	12	25	19	6	17	8	28	0,07
25543007	5/16"	0,750	13	29	21	8	21	10	31	0,10
25543010	3/8"	1,000	16	36	26	10	26	12	36	0,18
25543015	7/16"	1,500	18	40	29	11	28	14	42	0,25
25543020	1/2"	2,000	21	47	33	13	30	16	48	0,37
25543032	5/8"	3,250	27	59	43	16	42	20	60	0,71
25543047	3/4"	4,750	32	70	51	19	48	22	71	1,27
25543065	7/8"	6,500	36	80	58	22	57	27	84	1,78
25543085	1"	8,500	43	93	68	25	62	28	95	2,52
25543095	1 1/8"	9,500	46	104	74	29	69	33	103	3,53
25543120	1 1/4"	12,000	52	116	82	32	78	36	119	5,04
25543135	1 3/8"	13,500	57	127	92	35	86	39	133	6,84
25543170	1 1/2"	17,000	60	136	98	38	94	42	146	8,78
25543250	1 3/4"	25,000	73	161	127	44	112	52	178	14,09
25543350	2"	35,000	83	185	146	51	135	60	197	20,90
25543500	2 1/2"	55,000	105	232	184	64	152	70	267	39,90
25543850	3"	85,000	127	279	200	76	200	82	330	62,00
25543121	3 1/2"	120,000	137	321	232	92	220	95	374	109,00
25543151	4"	150,000	145	353	250	104	240	108	372	130,00

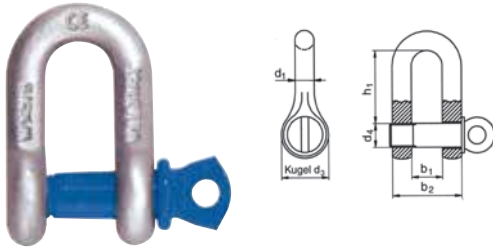

PİMLİ U MAPALAR / SHACKLE HIGH TENSILE U FORM WITH PIN

Kod No Art No.	Ölçü / Dimension ns	W.L.L. t	Ölçüler / Dimensions mm							Ağırlık / Weight kg
			b1	b2	d1	d4	h1	d3		
25540005	1/4"	0,500	12	26	6	8	22	17	0,05	
25540007	5/16"	0,750	13	29	8	10	26	21	0,08	
25540010	3/8"	1,000	16	36	10	12	31	26	0,13	
25540015	7/16"	1,500	18	40	11	14	36	28	0,19	
25540020	1/2"	2,000	21	47	13	16	41	30	0,31	
25540032	5/8"	3,250	27	59	16	20	51	42	0,55	
25540047	3/4"	4,750	32	70	19	22	60	48	0,96	
25540065	7/8"	6,500	36	80	22	27	71	57	1,41	
25540085	1"	8,500	43	93	25	30	81	62	2,03	
25540095	1 1/8"	9,500	46	104	29	33	90	69	2,97	
25540120	1 1/4"	12,000	52	116	32	36	100	78	4,01	
25540135	1 3/8"	13,500	57	127	35	39	113	86	5,40	
25540170	1 1/2"	17,000	60	136	38	42	124	94	7,29	
25540250	1 3/4"	25,000	73	161	44	52	146	112	11,25	
25540350	2"	35,000	83	185	51	60	171	135	16,20	
25540550	2 1/2"	55,000	106	232	63	72	203	158	33,30	

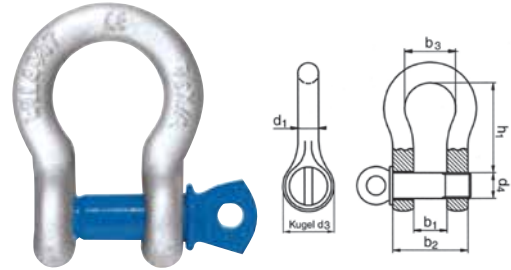

PİMLİ OMEGA MAPALAR / SHACKLE HIGH TENSILE OMEGA FORM WITH PIN

Kod No Art No.	Ölçü / Dimension ns	W.L.L. t	Ölçüler / Dimensions mm							Ağırlık / Weight kg
			b1	b2	b3	d1	d3	d4	h1	
25542005	1/4"	0,500	12	25	19	6	17	8	28	0,05
25542007	5/16"	0,750	13	29	21	8	21	10	31	0,08
25542010	3/8"	1,000	16	36	26	10	26	12	36	0,14
25542015	7/16"	1,500	18	40	29	11	28	14	42	0,22
25542020	1/2"	2,000	21	47	33	13	30	16	48	0,33
25542032	5/8"	3,250	27	59	43	16	42	20	60	0,65
25542047	3/4"	4,750	32	70	51	19	48	22	71	0,97
25542065	7/8"	6,500	36	80	58	22	57	27	84	1,46
25542085	1"	8,500	43	93	68	25	62	28	95	2,39
25542095	1 1/8"	9,500	46	104	74	29	69	33	103	3,15
25542125	1 1/4"	12,000	52	116	82	32	78	36	119	4,32
25542135	1 3/8"	13,500	57	127	92	35	86	39	133	5,67
25542170	1 1/2"	17,000	60	136	98	38	94	42	146	7,79
25542250	1 3/4"	25,000	73	161	127	44	112	52	178	12,51
25542350	2"	35,000	83	185	146	51	135	60	197	18,50
25542550	2 1/2"	55,000	106	232	184	63	158	72	267	37,58

Standart : U.S. Fed. Spec. RR-C-271 - EN 10204 - 3.1B
Malzeme : Yüksek mukavemetli çelik, söndürülmüş ve tavlanmış, Grade 6

Finis : Tüm parçalar sıcak daldırma, galvanizleme sonrası vida/pim üzeri mavi boyalı
Emniyet Faktörü : 6.0
Dökümantasyon : Test sertifikası



■ **Malzeme Montaj Liftleri**
Manuel Material Lifts

■ **Palet Kaldırma Çatalları**
Crane Forks

■ **Forklift Aksesuarları**
Forklift Accessories

■ **Sac Kaldırma Ekipmanları**
Plate Clamps

■ **Mıknatıs**
Magnet

■ **Hidrolik ve Mekanik Makine Krikoları**
Hydraulic and Mechanical Jacks

■ **Denge Ağırlıklı Vinçler**
Balanced Crane

■ **El Arabaları**
Hand Truck

■ **İş Güvenliği**
Personel Protection Equipment

**ENDÜSTRİYEL
KALDIRMA EKİPMANLARI**
INDUSTRIAL LIFTING EQUIPMENTS

MALZEME MONTAJ LİFTİ / MANUAL MATERIAL LIFT

	*NL-MML 10	*NL-MML 15	NL-MML 20	NL-MML 25	
Yük kapasitesi 400 mm yük merkezli / Load capacity at 400 mm load center/	350	300	250	200	kg
Kaldırma yüksekliği / Lifting height	3000	4500	6000	7400	mm
Destek ayağı uzunluğu / Length of wheel arms	1460	1840	2040	2040	mm
Kapalı uzunluk / Length stowed	740	740	740	790	mm
Standard gövde genişliği / Width standard base	800	800	800	800	mm
Kapalı yükseklik / Height stowed	1990	1990	1990	1990	mm
Standard gövde ağırlığı / Net weight standard base	117.9	143.8	183.7	204.1	kg

Art.No. 51500071	NL-MML 10
Art.No. 51500068	NL-MML 15
Art.No. 51500069	NL-MML 20
Art.No. 51500070	NL-MML 25

* Bu iki modelde denge ayağı bulunmamaktadır.



* NAKLİYE KOLAYLIĞI
* EASE OF TRANSPORT



PALET KALDIRMA ÇATALI / CRANE FORK

	NL-HCF 1.0	NL-HCF 1.5	NL-HCF 2.0	NL-HCF 3.0	NL-HCF 5.0	
Kaldırma kapasitesi / Capacity	1000	1500	2000	3000	5000	kg
Ayarlanabilir çatal aralığı / Adjustable range of fork (A)	350-900	350-900	400-900	450-900	530-1000	mm
Ayarlanabilir yükseklik / Effective height (B)	1100-1600	1300-2000	1300-2000	1300-2000	1300-2000	mm
Çatal uzunluğu / Length of fork (C)	1000	1000	1000	1000	1000	mm
Çatal ölçüleri / Fork cross section (D)	100 x 30	100 x 40	120 x 40	120 x 50	150 x 60	mm
Yükseklik / Height (E)	1390-1890	1600-2300	1640-2340	1670-2370	1700-2400	mm
Ağırlık / Weight	130	150	200	250	370	kg

Art.No. 52000148	NL-HCF 1.0
Art.No. 52000149	NL-HCF 1.5
Art.No. 52000150	NL-HCF 2.0
Art.No. 52000151	NL-HCF 3.0
Art.No. 52000152	NL-HCF 5.0

- Uluslararası standartlardadır.
- Avrupa güvenlik standartlarına uygundur.
- Kırılmayı önleyici 4 güvenlik noktasıdır.
- Bakım istemez.
- Çatalar birbirine yaklaştırılarak dairesel yükler de taşınabilir.
- Yükünüze göre ayarlanabilir çatal sistemlidir.
- Kapasitesinden 1.5 kat fazla yük ile test edilmiş dayanıklılık.
- Makine Emniyet Yönetmeliği 2006/ 42 EC' ye göre üretilmiştir.

- All crane forks are in conformity with European Union safety standart
- Four-insurance to avoid crack
- All the spare parts are maintenance free
- Round shape goods can be carried by adjusting the fork distance
- Adjustment of fork distance according to the size of tray
- Factory proof tested with 1.5 times the rated capacity
- Manufactured according to EU Machinery Directive 2006/ 42 EC



- Ayarlanabilir yükseklik
- Adjustable height

- Ayarlanabilir çatal genişliği
- Adjustable forks



- İkincil emniyet zinciri
- Secondary restraint chain

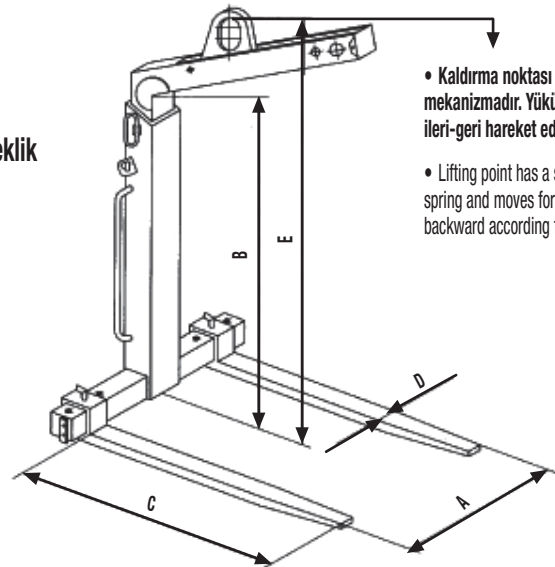

- Kaldırma noktası amortisörlü yaylı mekanizmadır. Yükün ağırlığına göre ileri-geri hareket eder.
- Lifting point has a shock absorber spring and moves forward and backward according to the weight.

BAKIM PLATFORMU / MAINTENANCE PLATFORM

Art.No. 51500001

NL-MFP 30

NL-MFP 30

Kaldırma kapasitesi / Capacity	300 kg
Platform ölçüleri / Deck size	950 x 950 mm
Maks. yükseklik / Max. height	2000 mm
Cep açıklıkları / Fork spread	600/ 690 mm

- Yüksekte güvenli çalışma imkânı.
 - İçeri doğru açılan, yay ve güvenlik mandallı kapı.
 - Pim ve zincir ile forklifte sabitleme imkânı.
 - Drenaj sistemli, kaymayı önleyici zemin.
 - MTE PM28 ve GN48 güvenlik ve sağlık standartlarına uygun.
 - Kurulumu ve nakliyesi kolay, az yer tutan yapı.
 - Tekerlekleri sayesinde yüksek manevra kabiliyeti.
- For overhead access and maintenance with safety.
 - Spring loaded inward opening door with safety latch for safety entry.
 - Unit is secured to the fork with heel pins and chain.
 - Slip-resistant floor with drainage holes.
 - Conforms to health and safety Guidance MTE PM28 and GN48 standard.
 - Less storage space, portable and easy to assemble.
 - Wheel fitted for easy manoeuvring



Tekerler opsiyoneldir.
Optional castors.



TELESKOBİK FORKLİFT PLATFORMU / TELESCOPIC FORKLIFT PLATFORM

Art.No. 51500094

NL-FP

NL-FP

Kaldırma kapasitesi / Capacity	210 kg
Max. platform yüksekliği / Max. machine height	4500 mm
Max. makine yüksekliği / Max. platform height	3000 mm
Makine boyu / Overall length	1900 mm
Makine genişliği / Overall width	1000 mm
Makine yüksekliği / Overall height	2000 mm
Platform zemin ölçüsü / Platform floor size	600 x 1000 mm
Güç kaynağı / Power supply	12 V/DC
Akü / Battery	12/ 120 V/Ah
Şarj cihazı / Integretad charger	90V/ 240 VAC 15 A V/A



ÇATAL UZATMA APARATI / FORK EXTENSION

	3KR57	3W667	3KR58	3KR59	6XX13	6XX14	6XX15	6XX16	
Çatal genişletme aparatı uzunluğu/ Fork ext. length	1525	1525	1830	1830	1830	2440	2440	2440	mm
Çatal genişliği / Fit fork width	100	125	125	150	100	100	125	150	mm
Min çatal uzunluğu / Min fork length	1015	1015	1220	1220	1220	1625	1625	1625	mm
Net ağırlık / Net weight (çifti/ per pair)	43	49	55	63	49	65.4	73	80.5	kg

Art.No. 52000188	NL-3KR57
Art.No. 52000189	NL-3W667
Art.No. 52000184	NL-3KR58
Art.No. 52000185	NL-3KR59
Art.No. 52000210	NL-6XX13
Art.No. 52000211	NL-6XX14
Art.No. 52000212	NL-6XX15
Art.No. 52000213	NL-6XX16

- Kaynaklı çelik konstrüksiyon.
- 50 mm çatalara kadar kullanılabilir.
- Kullanım esnasında kaymayı önleyen tutucu çelik bant mevcuttur.
- Uzun objelerin veya geniş paletlerin kaldırılmasında kullanılır.
- Uzatma aparatının uzunluğu, çatal uzunluğunu geçmemelidir.

- Welded steel construction.
- Fit on to forks up to 50 mm
- Steel retaining strap prevents fork extensions from sliding off forks during use.
- Designed to be used when long objects or large pallets must be lifted and moved with a fork truck.
- It is required that extensions do not exceed length of forks



TELESKOPİK FORKLİFT VİNCİ / TELESKOPIC FORK MOUNTED JIB

Pozisyon/ Position	Kapasite/ Capacity kg	Kol uzunluğu/ Length of arm/ mm
A	3000	755
B	2300	985
C	1865	1215
D	1570	1445
E	1355	1675
F	1190	1905
G	1061	2138
H	960	2367
I	875	2596
J	803	2825
K	743	3054
L	691	3283
M	648	3512
N	606	3741

- Bir forklifti seyir bir vince dönüştürerek uzun ve biçimsiz yükleri zor ulaşılan konulardan ve yerlerden hareket ettirir.
- Yük merkezi forkliftin yük merkezidir.
- Teleskopik forklift vinci çatalının üzerine geçirilip kaymayı engellemesi için bir zincir ile sabitlenir.
- Galvaniz kaplı çatal tutucusu sayesinde çatala sağlam ve emniyetli bir montaj olanağı sağlar.
- Bir adet firdöndülü kanca ve 1 adet mapa ile sunulmaktadır.

- Convert a forklift truck into a mobile crane to reach and transport long and awkward loads from inaccessible location.
- Verify load centre of forklift truck.
- Safety chain welded to boom has grab hook for anchoring jib boom to forklift truck.
- Zinc plated fork heels pin for safe forklift attachment.
- Supplied complete with one safety swivel hook with a bow shackle and one rigid hook.

Art.No. 52000162 NL-TFMJ

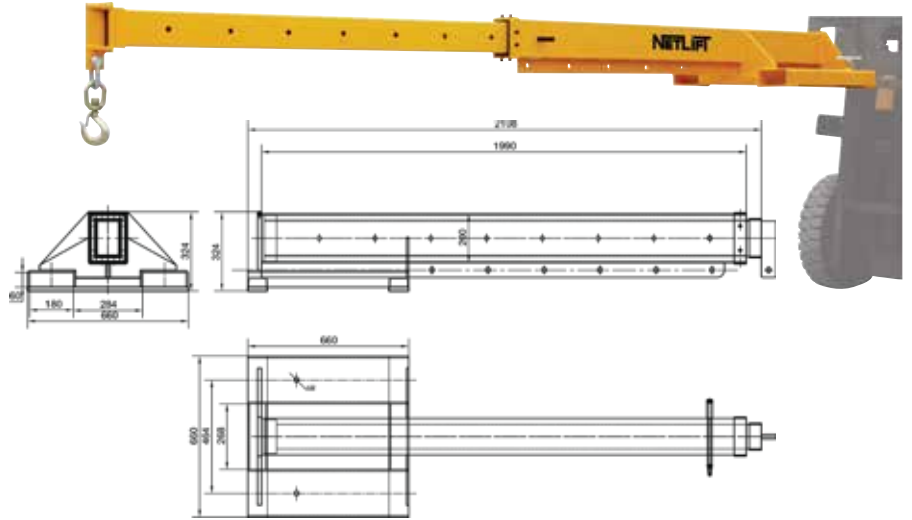
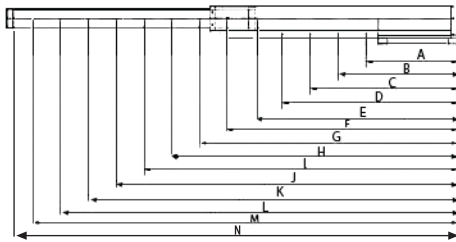

FORKLİFT ÇELİK KONTEYNER ATAŞMANI / STEEL CONTAINER

	NL-SC 150
Kapasite / Capacity	150 L
Konteyner Ölçü / Container size	750x600x500 mm
Toplam Boyut / Overall size	1100x780x800 mm
Döner Tekerlekler / Swivel casters	ø125 mm
Ön Tekerlekler / Front casters	ø125x2 mm
Çatal açıklığı / Fork opening	600 mm
Çatal cep / Fork pocket	150x55 mm
Ağırlık / Weight	103 kg

Art.No. 53000025 NL-SC 150



- Kolay hareket etmesini sağlayan tekerlekler
- Taşıma olanağı sağlayan forklift cepleri
- Equipped with casters for easily moving
- Fork pocket for easy transporting

YATAY SAC PLAKA KALDIRMA APARATI / HORIZONTAL PLATE CLAMP

		NL-HPC 75	NL-HPC 150	NL-HPC 250	
Çiftli kapasite / Capacity per pair		1.5	3	5	t
Test yükü / Proof test load (çiftli/ per pair)		22.07	44.13	73.58	kN
Max. ağız açıklığı / Max. jaw opening		25	30	40	mm
Ölçüler / Dimensions		0-27	0-32	0-52	mm
		125	157	231	mm
	A	50	65	90	mm
	B	175	204	310	mm
	C	25	30	40	mm
Ağırlık / Weight (Tek, single)	D Max	2.4	3.9	13.4	kg
Ağırlık / Weight (Çift, pair)	E	4.8	7.8	26.8	kg

Art.No. 52000066	NL-HPC 75
Art.No. 52000067	NL-HPC 150
Art.No. 52000068	NL-HPC 250

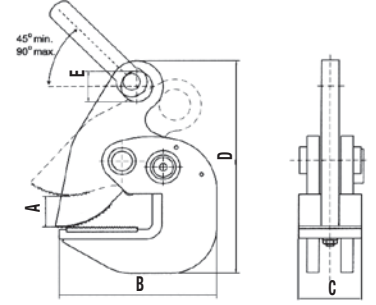

- Çift olarak kullanılması gereken bu sac kaldırma aparatları saçları yatay olarak yüklemeye ve kaldırmada büyük kolaylık sağlar.
- 2 bacaklı bir zincir sapanın ucuna takılmaları (max. açı 90°) saçları yatay kaldırmak için yeterlidir.
- Saclar uzun tarafından kaldırılmak istenirse zincir sapan bir kaldırma traversine monte edilmelidir.
- Önemli: Zincir sapanın max. kaldırma açısı 90° olmalıdır.
- Makine Emniyet Yönetmeliği 2006/ 42 EC'ye uygun üretilmiştir.

- Used in pairs this range of clamps is ideal for loading and moving plate material in the horizontal position
- A single pair of clamps fitted to a two leg chain sling (maximum sling angle 90°) is all that is required for lifting short lengths of plate
- For long plates, 2 pairs of clamps suspended by chain from a lifting beam must be used
- Important: Maximum sling angle is 90°
- Manufactured according to machinery directive 2006/ 42 EC

YATAY SAC KAPMA APARATI / HORIZONTAL PLATE LIFTING CLAMP

	YSK 0.8	YSK 1.0	YSK 1.6	YSK 2.5	YSK 3.2	YSK 5.0	
Çiftli kapasite / Capacity per pair	0.8	1	1.6	2.5	3.2	5	t / çift
Ağız açıklığı/ Jaw Opening	0-15	0-20	0-25	0-30	0-40	0-50	mm
Net Ağırlık / Net weight	2	4	6.5	11	12.5	19	kg

Art.No. 58900924	NL-YSK 0.8
Art.No. 58900925	NL-YSK 1.0
Art.No. 58900926	NL-YSK 1.6
Art.No. 58900927	NL-YSK 2.5
Art.No. 58900928	NL-YSK 3.2
Art.No. 58900929	NL-YSK 5.0



- Çelik plaka ve profilleri yatay ve dikey pozisyonda kaldırılması amacıyla tasarlanmıştır.
- % 150 aşırı yük testi uygulanmıştır.
- ANSI/ ASME B30. 20S. ve 2006/ 42/ EC Makine Emniyet Yönetmeliğine göre üretilmiştir.
- Designed lifting steel plate profile steel in horizontal and vertical direction, even overturn.
- 150 % overload factory tested.
- Conforms to EC Council Directive 2006/ 42/ EC Machinery American standard ANSI/ ASME B30. 20S.

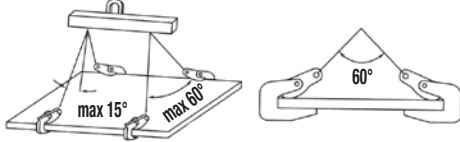

DİKEY SAC PLAKA KALDIRMA APARATI / UNIVERSAL PLATE CLAMP

		NL-HPZ 05	NL-HPZ 10	NL-HPZ 20	NL-HPZ 30	NL-HPZ 50	
Kaldırma kapasitesi / Capacity		0.5	1.0	2.0	3.0	5.0	t
Test yükü / Proof test load		7.35	14.7	29.4	44.1	73.5	kN
Ağız açıklığı / Jaw opening		0-15	0-20	0-25	0-30	0-50	mm
Ölçüler / Dimensions	A	30	48	70	75	80	mm
	B	44	63	76	85	90	mm
	C	35	51	56	59	65	mm
	D	0-17	0-22	0-27	0-32	0-52	mm
	E	103	138	164	193	240	mm
	F	10	12	16	20	22	mm
	G	212	295	370	418	450	mm
	H	35	51	52	78	88	mm
Ağırlık / Weight		1.9	4.8	6.5	14.8	22.5	kg

Art.No. 52000074	NL-HPZ 05
Art.No. 52000075	NL-HPZ 10
Art.No. 52000076	NL-HPZ 20
Art.No. 52000077	NL-HPZ 30
Art.No. 52000078	NL-HPZ 50

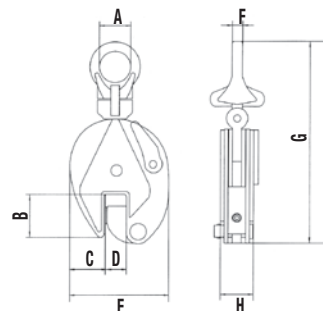

- Sacı, farklı açılardan güvenle kaldırmanızı sağlayan özel dizayn.
- Her pozisyonda saçın sağlam tutulmasını sağlayan oynar yapı.
- Güvenli tutuş ve kilitleme mekanizması için sert çelikten yapılmış çeneler.
- HRC30/Brinell300 ve üstü çelik tiplerine uygun
- % 150 aşırı yük testli.
- EC Council Directive 2006/ 42 EC Machinery, ve American Standard ANSI/ASME B30.20'ye uygun üretilmiştir.

- Designed for the safe handling of plate at various angles.
- The pivoting shackle ensures adequate gripping pressure to hold the plate safely in every position.
- Hardened steel jaws for positive grip and locking mechanism.
- Suitable for all structural steel up to HRC30/Brinell 300.
- 150 % overload factory tested.
- Manufactured according to EC Council Directive 2006/42 EC Machinery, American Standard ANSI/ASME B30.20.

YATAY KALDIRMA APARATI / HORIZONTAL LIFTING CLAMP

	NL-YCT 2.0	NL-YCT 4.0	NL-YCT 6.0	
Çiftli kapasite / Capacity per pair	2000	4000	6000	kg
Test yükü / Proof test load (çiftli/ per pair)	4000	8000	12000	kg
Max. ağız açıklığı / Max. jaw opening	5 - 32	5 - 50	5 - 75	mm
Ağırlık / Weight (Çift, pair)	8.5	15.5	34.5	kg

- İki bacaklı zincir sapan ile kullanıma uygundur. • It is especially suited for the transport of single plate with a minimum thickness of approx. 5 mm as well as for plate bundles.
- Travers ile kullanıma uygundur. • The two legged lifting clamps in conjunction with a spreader beam.
- Plakaların tekli ve çoklu kaldırılmasında kullanılır. •



Art.No. 52000313	NL-YCT 2.0
Art.No. 52000314	NL-YCT 4.0
Art.No. 52000315	NL-YCT 6.0

YÜK MAKARASI / PULLEY BLOCKS

	NL-HPB 10	NL-HPB 20	NL-HPB 32	NL-HPB 64		
Çalışma yükü / Working load	1000	2000	3200	6400	kg	
Mandal açıklığı / Hook hatch	23	27	31	42	mm	
Halat ölçüsü / Rope diameter	07	013	015	018	mm	
Ölçüler / Dimensions	B	118	199	230	270	mm
	B1	76	92	108	116	mm
	B2	17	24	28	35	mm
	C	23	27	31	42	mm
	D1	85	150	180	210	mm
	D2	105	190	220	260	mm
	L	305	425	496	655	mm
	L1	200	263	295	375	mm
	L2	23	30	40	47	mm
	R	4	7	9	10	mm
Ağırlık / Weight	3.3	8.9	15.5	26.5	kg	



Art.No. 52000079	NL-HPB 10
Art.No. 52000080	NL-HPB 20
Art.No. 52000081	NL-HPB 32
Art.No. 52000082	NL-HPB 64

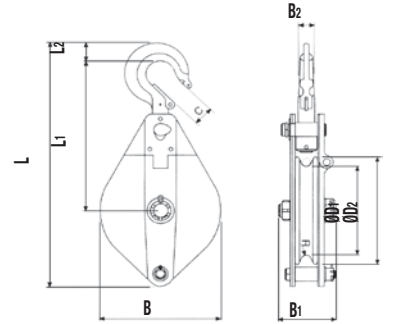

- Netlift yük makaralarının bir yüzü halatın bobine rahat yerleştirilebilmesi için açılabilir. • One side of the NETLIFT pulley blocks is hinged and can be opened for easy and quick positioning of the rope on the sheave.
- Kancanın çekim yönüne hareketi kasnak bloğunu güvenli bir şekilde kilitlet.
- Yüksek kaliteli çelikten imal edilmiş bobinlerin yivleri özel makinelerde açılmıştır. • Swinging the hook in the direction of pull securely locks the pulley block.
- prEN13157:2003 ve Machinery Directive 2006/ 42 EC'ye göre imal edilmiştir. • The high quality cast steel sheaves have machined grooves
-
- Manufactured according to prEN 13157:2003, machinery directive 2006/ 42 EC

YÜK KALDIRMA MIKNATISI / LIFTING MAGNET

	LD 01	LD 03	LD 06	LD 10	LD 20	LD 30	LD 50	
Çalışma yük limitleri / Working load limits	100	300	600	1000	2000	3000	5000	kg
Kanıtlanmış test yükü / Proof test load	350	1050	2100	3500	6000	9000	15000	kg
Uzunluk / Length (L)	100	175	225	280	360	435	540	mm
Genişlik / Width (B)	82	105	140	160	210	286	316	mm
Yükseklik / Height (H)	80	100	125	155	185	245	295	mm
Ağırlık / Weight	5.5	11.5	26.5	48	80	180	380	kg

Art.No. 52000153	NL-LD 01
Art.No. 52000154	NL-LD 03
Art.No. 52000155	NL-LD 06
Art.No. 52000156	NL-LD 10
Art.No. 52000157	NL-LD 20
Art.No. 52000158	NL-LD 30
Art.No. 52000159	NL-LD 50

	Çelik kalınlığı / Thickness of Steel		Kapasite oranı / Capacity rate							
	mm	inch	LD 30	LD 20	LD 10	LD 06	LD 03	LD 01		
T1	Up to 60	Up to 2.36	100%	100%						
T2	55	2.16	95%							
T3	50	1.97	90%	95%	100%					
T4	45	1.77	85%	90%		100%				
T5	40	1.57	80%	85%			100%			
T6	35	1.38	70%	75%	90%					
T7	30	1.18	60%	65%	80%					
T8	25	0.98	50%	55%	70%	90%				
T9	20	0.79	40%	45%	60%	75%	90%			
T10	15	0.59	30%	35%	50%	60%	70%			
T11	10	0.39	20%	25%	35%	45%	50%	70%		
T12	5	0.20	10%	15%	20%	25%	30%	40%		

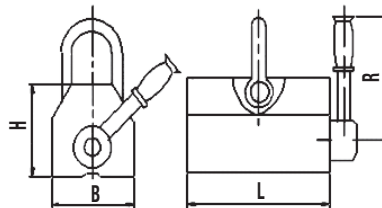

MEKANİK KRİKO / MECHANICAL JACK

	NL-MJ 1.5	NL-MJ 3.0	NL-MJ 5.0	NL-MJ 10	NL-MJ 16	
Kapasitesi / Capacity	1.5	3	5	10	16	t
Test Yüğü / Proof test load	22	44.1	73.5	147	235	kN
Kaldırmada harcanan güç / Hand force to lift rated load	280	350	400	580	800	N
Ölçüler / Dimensions	A	81	83	108	124	130 mm
	B	100	130	140	140	150 mm
	C	600-900	735-1090	730-1075	800-1190	820-1140 mm
	D	60-360	70-425	80-425	100-490	90-410 mm
	E	55	60	71	86	80 mm
	F	46	45	68	76	85 mm
	G	110	138	170	170	180 mm
	H	225	249	249	300	400 mm
	K	147	170	190	252	251 mm
	R	119	140	155	185	220 mm
S	175	235	217	187	210 mm	
T	113	128	128	250	280 mm	
Ağırlık / Weight	14	20	28	46	63	kg

Art.No. 52000083	NL-MJ 1.5
Art.No. 52000084	NL-MJ 3.0
Art.No. 52000085	NL-MJ 5.0
Art.No. 52000086	NL-MJ 10
Art.No. 52000087	NL-MJ 16

- Yeni nesil mekanik krikolar
- Araç tamirlerinde ve kamyon kasalarını kaldırmada kullanım için dizayn edilmiştir.
- %150 aşırı yük testidir.
- Ağır işler için ideal, dayanıklı ve sağlamdır.

- Replacement of conventional jaks
- Designed for repairing the vehicles and lifting the tracks
- 150% overload factory tested
- Heavy duty structure, high stability and long life.

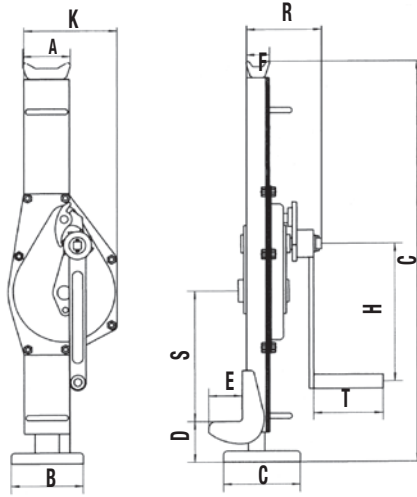

MAKİNE KRİKOSU / MACHINE JACK

	NL-HJ 50	NL-HJ 100	
Kapasitesi / Capacity	5.0	10.0	t
Tırnak kaldırma aralığı / Lifting range of foot	25-230	30-260	mm
Üst kaldırma aralığı / Lifting range of head	368-573	420-650	mm
Max. kol kuvveti / Max. lever force	38	40	kg
Ağırlık / Weight	25	35	kg

Art.No. 52000088	NL-HJ 50
Art.No. 52000089	NL-HJ 100

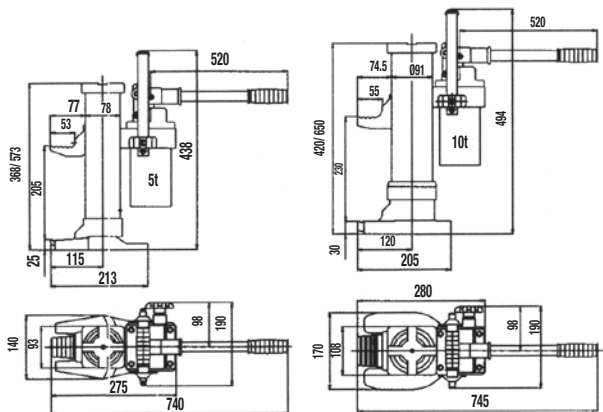

- Kompakt ve dayanıklı.
- 360o dönebilen gövde.
- Ayarlanabilir indirme hızı.
- Aşırı yük önleyici mekanizma.
- Çıkarılabilir pompa kolu.

- Compact and resistant.
- Body turns 360o.
- Adjustable lowering speed.
- Overloaded preventive mechanism.
- Portable pump rod.

TIRNAKLI KRİKO / TOE JACK

	NL-TK 3	NL-TK 8	
Kaldırma kapasitesi / Capacity	3000	8000	kg
Min. ayak yüksekliği / Min. fork height	15	20	mm
Kaldırma yüksekliği / Lifting height	140	140	mm
Ağırlık / Weight	21	27	kg



Art.No. 59000103

NL-TK 3

Art.No. 59000104

NL-TK 8

FORKLİFT KRİKOSU / FORKLIFT JACK

	NL-A400	NL-A700	
Kapasite / Capacity	4000	7000	kg
Min. kaldırma yüksekliği / Min. lifting height	65	65	mm
Max. kaldırma yüksekliği / Max. lifting height	406	420	mm
Genişlik / Width	203	73	mm
Net ağırlık / Weight	33	31	kg

Art.No. 59000055

NL-A400

Art.No. 59000056

NL-A700



NL-A700

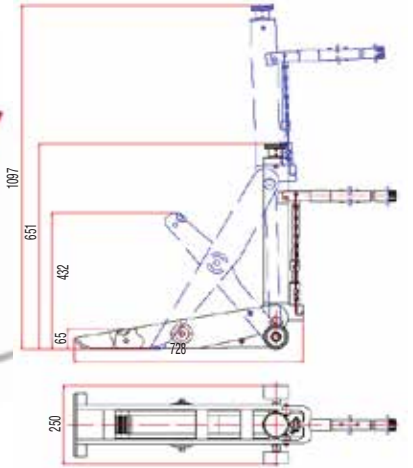

HİDROLİK ŞİŞE TİPİ KRİKO / HYDRAULIC BOTTLE TYPE JACK

	A002	A003	A005	A008	A010	A012	
Kaldırma kapasitesi / Capacity	2000	3000	5000	8000	10000	12000	kg
Minimum yükseklik / Min. height	181	194	216	230	230	230	mm
Kaldırma yüksekliği / Lifting height	116	118	127	147	150	155	mm
Net ağırlık / Net weight	2.9	3.6	4.8	6.3	6.8	8.0	kg

Art.No. 59000029

NL-A002

Art.No. 59000030

NL-A003

Art.No. 59000031

NL-A005

Art.No. 59000032

NL-A008

Art.No. 59000033

NL-A010

Art.No. 59000034

NL-A012



- 10 tona kadar plastik kutulu ambalajlarda
- Plastic box (For jack up to 10 tons)

PICK-UP VİNCİ / PICK-UP CRANE

NL-A027

Kaldırma kapasitesi / Capacity	900 kg
Minimum yükseklik / Min. height	580 mm
Maksimum yükseklik / Max. height	2400 mm
Çalışma mesafesi / Boom length	870 - 1290 mm
Ölçüler / Dimensions (LxWxH) (boy x en x yükseklik)	340 x 330 x 500 mm
Net ağırlık / Weight	52 kg
Brüt ağırlık / Gross weight	55 kg



Art.No. 59000014

NL-A027

HİDROLİK GARAJ VİNCİ / HYDRAULIC SHOP CRANE

NL-A028

Kaldırma kapasitesi / Capacity	3000 kg
Çalışma mesafesi / Min.-Max. boom length	1325 - 1925 mm
Ölçüler / Dimensions (LxWxH) (boy x en x kapalı yükseklik)	2200 x 790 x 1550 mm
Net ağırlık / Weight	110 kg
Brüt ağırlık / Gross weight	115 kg

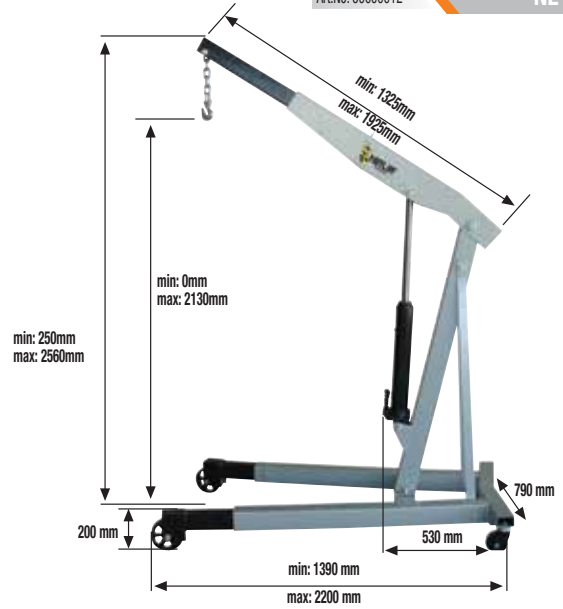

Art.No. 59000012

NL-A028

KATLANIR MOTOR VİNCİ (Ağır Hizmet) / SHOP CRANE (Heavy Duty)

NL-A072

Kaldırma kapasitesi / Capacity	2000 kg
Minimum yükseklik / Min. height	489 mm
Maksimum yükseklik / Max. height	1889 mm
Ölçüler / Dimensions (LxWxH) (boy x en x yükseklik)	1565 x 925 x 1450 mm
Net ağırlık / Weight	108 kg
Brüt ağırlık / Gross weight	114 kg



Art.No. 59000011

NL-A072

Katlanabilme özelliği sayesinde dar alanlarda rahat kullanılır.
Unique folding design helps storage after using in a space-limited work shop.

DENGELİ AĞIRLIKLI VİNÇ / COUNTER BALANCED SHOP CRANE

	NL-CBSC 1	NL-CBSC 2	NL-CBSC 3	
Yükleme kapasitesi / Load Capacity	550	550	550	kg
930 kol uzunluğunda maksimum yük / Max load at jib length 925	550	550	550	kg
1210mm kol uzunluğunda maksimum yük / Max load at jib length 1210	400	400	400	kg
1500mm kol uzunluğunda maksimum yük / Max load at jib length 1500	300	300	300	kg
1800mm kol uzunluğunda maksimum yük / Max load at jib length 1800	220	220	220	kg
2080mm kol uzunluğunda maksimum yük / Max load at jib length 2080	150	150	150	kg
Hidrolik pompa / Hydraulic Pump	Manuel	Yarı Akülü	Tam Akülü	
Sürüş hızı / Driving speed	Manuel	Manuel	2.0km/h	km/h
Motor gücü / Motor power		0.8/12	0.8/24	kW/V
Tekerlek / Wheel	Pu/Naylon Ø 180	Pu/Naylon Ø 180	Pu/Naylon Ø 180	mm
Maks. vinç kolu uzunluğu / Max. crane arm length	2100	2100	2100	mm
Min. vinç kolu uzunluğu / Min. crane arm length	920	2100	2100	mm
Kald. yüks. maks. kol uzunluğunda / Lifting height max. cantilever arm extended	2600	2600	2600	mm
Toplam boyut L x G x Y / Overall Size LxWxH	2241x905x1498	2241x905x1498	2241x905x1498	mm
Toplam ağırlık / Total Weight	530	530	560	kg
Batarya / Battery	-	12/60	24/60	V/Ah
Şarj cihazı / Charger	-	12/8	24/8	V/A

Art.No. 5200187-1	NL-CBSC 1
Art.No. 5200187-2	NL-CBSC 2
Art.No. 5200187-3	NL-CBSC 3

- Ergonomik kumanda kolu, mobil ve katlanabilir tasarım
- Çift tesirli hidrolik pompa ile hızlı ve kolay çalışma olanağı sağlar.
- Makinenin yakınında çalışmayı sağlar.

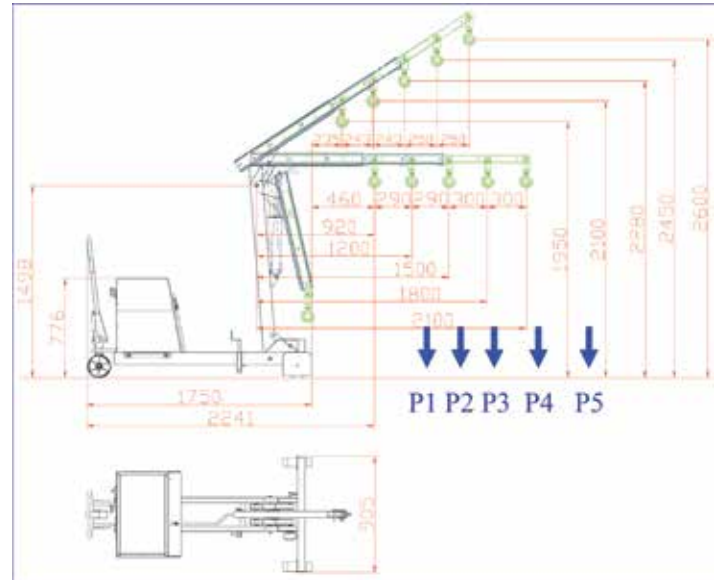
NL-CBSC 1
ManuelNL-CBSC 2
Yarı akülü
(kaldırma akülü)NL-CBSC 3
Tam akülü
(kaldırma ve yürütme akülü)

YÜK TAŞIMA ARABALARI / TRANSPORT TROLLEYS

	Tekerlek sayısı No. of rollers	Dönüş tablası ölçüsü Dimensions of turnplate (mm)	Kol boyu/ ayarlanan genişlik boyu Length of handle / adjusting length of lever L (mm)	Ölçüler Overall size (mm)	Kapasite Capacity (ton)	Ağırlık Weight (kg)	
NL-X4+Y4	X4	4	150	800	230 x 230 x 110	8	28
	Y4	4	140 x 120	300 - 1000	170 x 140 x 110		
NL-X8+Y8	X8	8	160	1100	560 x 420 x 110	16	72
	Y8	8	200 x 160	400 - 1300	200 x 200 x 110		
NL-X12+Y12	X12	12	180	1100	750 x 450 x 110	24	100
	Y12	12	220 x 180	400 - 1400	256 x 200 x 110		
NL-X16+Y16	X16	16	200	1100	936 x 500 x 110	32	124
	Y16	16	240 x 200	400 - 1500	310 x 220 x 110		
NL-X18+Y18	X18	18	200	1500	780 x 550 x 110	36	138
	Y18	18	280 x 200	400 - 1500	300 x 550 x 110		

*PU teker

Art.No. 52000132	NL-X4+Y4
Art.No. 52000133	NL-X8+Y8
Art.No. 52000135	NL-X12+Y12
Art.No. 52000136	NL-X16+Y16
Art.No. 52000137	NL-X18+Y18

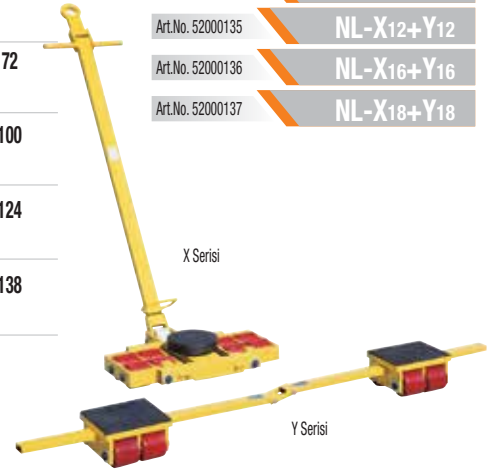

AĞIR YÜK TAŞIMA ARABASI / HEAVY SKATE KIT

	NL-SK 20	NL-SK 30	
Kapasite / Capacity	20	30	t
Uzunluk / Length	120	120	mm
Genişlik / Width	120	120	mm
Toplam yükseklik / Total height	108	117	mm
Silindireler / Cylinders	18	24	mm
Döner Tabla / Rotary Table	130	130	mm
Ağırlık / Weight	50	58	kg

Art.No. 61500020	NL-SK 20
Art.No. 61500030	NL-SK 30



ARAÇ TRANSFER KRIKOSU / GO JACK

	NL-A098	
Kapasite / Capacity	1500	kg/çift
Ölçüler / Dimensions	680 x 620 x 220	mm
Net ağırlık / Net weight	18	kg
Brüt ağırlık / Gross weight	20	kg

Art.No. 59000027	NL-A098
------------------	---------



DÖRTLÜ TAŞIMA STANDI / GO JACK SET

- Krikoları düzenli bir şekilde muhafaza etmeyi sağlar.
- Jack stand makes the storage easy.

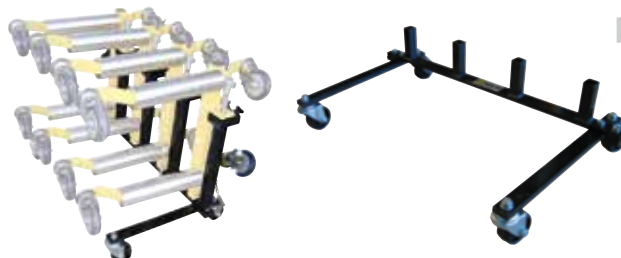

Art.No. 59000028	NL-A099
------------------	---------

TEKERLEKLİ MANİVELA / ROLLER CROW BAR**NL-RC 3****NL-RC 5**

Art.No. 52000138

NL-RC 3

Art.No. 52000139

NL-RC 5

	NL-RC 3	NL-RC 5	
Kaldırma kapasitesi / Capacity	3	5	t
Uzunluk / Length	2000	2500	mm
Max. kaset yüksekliği / Max. skate height	200	250	mm
Tekerlek çapı / Roller diameter	100	125	mm
Tekerlek genişliği / Roller width	55	65	mm
Ağırlık / Weight	13	18	kg

**PALET ÇEKME KISKACI / PALLET PULLER****NL-PCD****NL-PCS**

Art.No. 52000168

NL-PCD

Art.No. 52000169

NL-PCS

	NL-PCD	NL-PCS	
Maks. çene aralığı / For stringers	76.2	140	mm
Uzunluk / Length	762	495	mm

- Palet çekme kısıkaçları özellikle konteyner içinde ve tır dorselerinde, paletleri forkliftlerin ulaşabileceği yakınlığa çekerek indirme işlerinizi kolaylaştırır.
- PCD93: Tırtıllı ağız sayesinde paletleri kolayca kavrar. Çift makaslıdır.
- PCS81: Tek makaslı modeldir ve daha geniş ağız açıklığına sahiptir.

- Pallet puller are used to pull pallets to rear of trailers for easy fork lift access.
- PCD93: One-piece curved heads have integral spurs for gripping pallet stringers. Double scissor action.
- PCS81: Single scissor action allow for wider jaw opening.

**NL-PCD****NL-PCS****ŞASE DOĞRULTMA SETİ / PORTABLE HYDRAULIC EQUIPMENT****NL-A004**

Art.No. 59000017

NL-A004

	NL-A004	
Kapasite / Capacity	10000	kg
Minimum yükseklik / Min. height	355	mm
Maksimum yükseklik / Max. height	490	mm
Kaldırma mesafesi / Lifting height	135	mm
Öçüler / Dimensions	93 x 39 x 17	mm
Net ağırlık / Weight	26	kg
Brüt ağırlık / Gross weight	31	kg



PAKET TAŞIYICISI / HAND TRUCK

	NL-104	NL-105
Kapasite / Capacity	250	150 kg
Genişlik / Width	610	480 mm
Uzunluk / Length	910	740 mm
Yükseklik / Height	870	830 mm
Ambalaj ebadı / Package dimensions	920 x 620 x 150	740 x 480 x 120 mm
Ağırlık / Weight	16.20	8 kg

Art.No. 52000173

NL-104

Art.No. 52000174

NL-105



NL 104



NL 105



PAKET TAŞIYICISI / HAND TRUCK

	NL-106
Kapasite / Capacity	350 kg
Genişlik / Width	610 mm
Uzunluk / Length	910 mm
Yükseklik / Height	960 mm
Ambalaj ebadı / Package dimensions	920 x 620 x 150 mm
Ağırlık / Weight	20 kg

Art.No. 52000175

NL-106



PLATFORM EL ARABASI / PLATFORM TRUCK

	NL-109
Kapasite / Capacity	500 kg
Platform ölçüsü / Platform size	1200 x 800 mm
Platform yüksekliği / Platform height	270 mm
Teker ölçüsü / Wheel size	200 x 45 mm
Ambalaj ebadı / Package dimensions	1300 x 800 x 1170 mm
Ağırlık / Weight	38 kg

Art.No. 52000178

NL-109



- Görsel tanımlama: çelik ağı korumalı el arabası.
- Paneller isteğe göre yer değiştirilebilir.
- Her açıdan ve taraftan yüklenebilir.
- 2 Teker yön verme amacı ile dönebilmekte ve fren tertibatı bulunmakta, diğerleri sabit lastikten oluşup çapları 200mm'dir.
- Demonte olarak gönderilmekte. Montajı son derece kolaydır.
- For visual identification on the move, platform trucks with steel mesh panels.
- Panels individually removable.
- Load visible from all directions.
- 2 swivel castors with brake and 2 fixed wheels, rubber tyres, Ø200mm, roller bearings.
- Delivered flat packed for easy bolt-on assembly.

PAKET TAŞIYICISI / HAND TRUCK

Art.No. 52000294

NL-111

NL-111

Kapasite / Capacity	200	kg
Platform genişliği / Platform Width	350	mm
Toplam Genişlik / Total Width	540	mm
Uzunluk / Length (L)	200	mm
Yükseklik / Height(H)	1170	mm
Tekerlek çapı / Caster wheel dia.	260	mm
Ağırlık / Weight	14.8	kg



PAKET TAŞIYICISI / HAND TRUCK

Art.No. 52000295

NL-112

NL-112

Kapasite / Capacity	200	kg
Platform genişliği / Platform Width	220	mm
Toplam Genişlik / Total Width	530	mm
Uzunluk / Length (L)	220	mm
Yükseklik / Height(H)	1050	mm
Tekerlek çapı / Caster wheel dia.	260	mm
Ağırlık / Weight	11	kg



PAKET TAŞIYICISI / HAND TRUCK

Art.No. 52000299

NL-116

NL-116

Kapasite / Capacity	150	kg
Platform genişliği / Platform Width	450	mm
Toplam Genişlik / Total Width	500	mm
Uzunluk / Length (L)	260	mm
Yükseklik / Height(H)	1170	mm
Tekerlek çapı / Caster wheel dia.	260	mm
Ağırlık / Weight	9.7	kg



PAKET TAŞIYICISI / HAND TRUCK

Art.No. 52000300

NL-117

NL-117

Kapasite / Capacity	150	kg
Platform genişliği / Platform Width	350	mm
Toplam Genişlik / Total Width	550	mm
Uzunluk / Length (L)	270	mm
Yükseklik / Height(H)	1190	mm
Tekerlek çapı / Caster wheel dia.	260	mm
Ağırlık / Weight	16.7	kg



TÜP TAŞIMA ARABASI / CYLINDER TROLLEY

NL-123

NL-124

Tüp Kapasite / Cylinder Capacity	10/20/40/50	40/50	lt
Tüp Çapı / Cylinder Diameter	140-250	210-250	mm
Tekerlek / Wheel	ø200x50	ø400x50	mm
Ölçüler / Overall size	660x600x1360	700x700x1380	mm
Ağırlık / Weight	17	45	kg
Tip / Type	Tek tüp	Çift tüp	

NL-123
(Tek tüp)NL-124
(Çift tüp)

Art.No. 52000290

NL-123

Art.No. 52000291

NL-124

TÜP MUHAFAZA STANDI / GAS CYLINDER TRUCK

NL-125

Tüp Kapasite / Cylinder Capacity	40	lt
Tüp Çapı / Cylinder Diameter	230	mm
Toplam boyut / Overall size	540x360x1000	mm
Ağırlık / Weight	18	kg



Art.No. 52000292

NL-125

YÜK TAŞIYICI / CORNER MOVERS

NL-MTE 02

Birim kapasite / Max. load each	150 kg
Teker çapı / Castor diameter	50 x 20 mm
Yükleme yüksekliği / Load height	15 mm
Toplam ölçüler / Overall Size	366 x 204 x 85 mm
Çerçeve hammaddesi / Frame material	Çelik/ Steel/ Stahl
Net ağırlık / Net weight (çiftli/ per pair)	8 kg

- Düşük yükseklığe sahip köşeli yük taşıyıcısı.
- Diğer ekipmanların kullanılmayacağı yerde çözüm ortağınız.
- Kolay yükleme.
- Yükün bindiği yüzeylerdeki kaydırmazlastikler sayesinde güvenlidir.
- Çelikten mamüldür.
- Her bir taşıyıcıda rulmanlı 3 teker vardır.
- 1 sette 4 adet mevcuttur.



Art.No. 52000143

NL-MTE 02



Art.No. 52000146

NL-DS 400A

Art.No. 52000147

NL-DS 400B

ÇELİK YÜK TAŞIMA ARABASI / STEEL DOLLIES

NL-DS 400A

NL-DS 400B

Kapasite / Capacity	400	400 kg
Platform ölçüleri / Suit for container size	600 x 400	800 x 600 mm
Toplam ölçüler / Overall size	600 x 400 x 130	800 x 600 x 130 mm
Döner tekerlek sayısı / No. of swivel castor	4	4 adet
Tekerlek çapı / Castor diameter	100	100 mm
Net ağırlık / Net weight	9	11 kg

- Kaynaklı, açılı çelik konstrüksiyon.
- Yüksekliğini güçlendiren orta destek çubukları.
- Welded angle steel construction.
- Flat deck area with intermediate support bars.



MANUEL TAŞIYICI / MECHANIC LIFTER

NL-MR 200

Kaldırma kapasitesi / Capacity	200 kg
Max. platform yüksekliği / Max. platform height	120 mm
Min. platform yüksekliği / Min. platform height	95 mm
Çatal genişliği / Fork width	220 mm
Çatal uzunluğu / Fork length	580 mm
Ön tekerlek / Front wheel	5 x 32 mm
Arka tekerlek / Rear castor	25 x 32 mm
Platform ölçüleri / Platform size	215 x 575 mm
Makine ölçüleri / Overall size	920 x 510 x 1040 mm
Net ağırlık / Net weight	21 kg



Art.No. 52000183

NL-MR 200

KONVEYÖR ATAÇMANI / CONVEYOR ATTACHMENT

NL-HPT-RT 1020

Kapasite / Capacity	1000 kg
Platform ölçüleri / Platform size	2000 x 500 mm

- EN 1757-1 ve EN 1175-1 e uygundur.
- Conforms to EN 1757-1 and EN 1175-1.



- İstif makinesi temsili kullanılmıştır, ürün dahilinde değildir.
- The stacker is only a representative and is not included in the product.



Art.No. 52000161

NL-HPT-RT 1020

TRİPOD / SAFETY TRIPOD

NL-SNV 900

Kapasite / Capacity	180	kg
Ayak uzunluğu / Cable Length	1340 - 2140	mm

*Vinç fiyata dahil değildir.



Art.No. 54000050

NL-SNV 900

TRİPOD VINÇİ / HAND WINCH FORTRIPOD

NL-SNV 820

NL-SNV 825

Kapasite / Capacity (Vinç, winch)	180	180	kg
Halat kopma yükü / Wire rope breaking load	1800	1800	kg
Halat uzunluğu / Cable Length	20	25	m
Halat çapı / Wire rope diameter	6.3	6.3	mm
Ağırlık / Weight	13	13.4	kg

- Otomatik frenli ırgat EN 1496

³ Handwinch with automatic brake acc EN 1496



Art.No. 54000036

NL-SNV 820

Art.No. 54000037

NL-SNV 825

BALANSÖR / FALL ARRESTER

NL-CR 06

NL-CR 10

NL-CR 12

NL-CR 15

Halat uzunluğu / Cable length	6	10	12	15	m
Ölçüler / Dimensions	208 x 85 x 280	208 x 85 x 280	208 x 85 x 280	208 x 85 x 280	mm
Ağırlık / Weight	5.10	5.30	5.90	6.10	kg

- Paslanmaz çelik halka
- Stainless steel ring
- Plastik gövde
- Plastic case
- Galvanizli çelik halat Ø4 mm
- Zinc galvanized steel cable Ø4 mm



Art.No. 54000038

NL-CR 06

Art.No. 54000039

NL-CR 10

Art.No. 54000040

NL-CR 12

Art.No. 54000041

NL-CR 15

PARAŞÜT TİPİ EMNİYET KEMERİ / SAFETY HARNESS

Ön ve arka ankraj noktasına sahip, pozisyonlama kemeri olan, bel destekli emniyet kemeri. Bacak ve omuzlarda tek ayar tokası mevcuttur.

- Çift renk düşüş önleme ve konumlandırma kemeri
- Tam boy emniyet kemeri: 2 düşme önleyici bağlantı noktası (arka-göğüs).
- Isıl biçimlendirilmiş arka destekli iş konumlandırma kemeri.
- 2 iş konumlandırma bağlantı noktası (yanal).
- 3 ayarlama tokası.
- 2 fall arrester anchorage point harness (back - front).
- 2 adjustment loops. 2 adjustable lateral plates.
- Positioning belt with broad thermoformed back.
- Sponge lining.
- 2 anchorage points for work positioning
- 3 adjustable lateral plates.



Art.No. 41000129

NP-05S

Art.No. 41000130

NP-01S

Sadece arka ankraj noktasına sahip, omuz ve bacak bantları için tek ayar tokasına sahiptir.

- Tek renk düşüş önleme ve konumlandırma kemeri
- 1 düşme önleyici bağlantı noktası (arka)
- 2 ayarlama tokası
- 1 fall arrester anchorage point harness (back).
- 2 adjustment loops.
- 2 adjustable lateral plates.





NET MAK
METAL MAKİNE SANAYİ VE TİCARET LTD. ŞTİ.

Fırdöndü Kaldırma Mapaları

Her türlü kaldırma ve bağlama uygulaması için

www.netmak.com.tr

REL P Fırdöndü Kaldırma Mapası Çalışma Yük Limitleri

Sapın bacak sayısı	1		2		2 simetrik		3 & 4 simetrik		Tork anahtarı	Allen anahtarı
	0°*	90°	0°	90°	0-45°	45-60°	0-45°	45-60°		
REL P - M8	0.7	0.3	1.4	0.6	0.4	0.3	0.6	0.4	10 Nm	8.0
REL P 5/16"-18 UNC	0.7	0.3	1.4	0.6	0.4	0.3	0.6	0.4	7Ft.Lbs	5/16"
REL P - M10	1.2	0.5	2.4	1.0	0.7	0.5	1.0	0.7	15 Nm	8.0
REL P 3/8"-16 UNC	1.2	0.5	2.4	1.0	0.7	0.5	1.0	0.7	11Ft.Lbs	5/16"
REL P - 12	2.0	0.8	4.0	1.6	1.1	0.8	1.6	1.2	27 Nm	8.0
REL P 1/2"-13 UNC	2.0	0.8	4.0	1.6	1.1	0.8	1.6	1.2	20Ft.Lbs	5/16"
REL P - M16	3.5	1.5	7.0	3.0	2.1	1.5	3.1	2.2	60 Nm	8.0
REL P 5/8"-11 UNC	3.5	1.5	7.0	3.0	2.1	1.5	3.1	2.2	44Ft.Lbs	5/16"

RLP Fırdöndü Kaldırma Mapası Çalışma Yük Limitleri

Sapın bacak sayısı	1		2		2 simetrik		3 & 4 simetrik		Tork anahtarı	Allen anahtarı
	0°*	90°	0°	90°	0-45°	45-60°	0-45°	45-60°		
RLP - M8	0.8	0.4	1.6	0.8	0.5	0.4	0.8	0.6	10 Nm	13 mm
RLP 5/16"-18 UNC	0.8	0.4	1.6	0.8	0.5	0.4	0.8	0.6	7Ft.Lbs	1/2"
RLP - M10	1.2	0.7	2.4	1.4	0.9	0.7	1.4	1.0	15 Nm	13 mm
RLP 3/8"-16 UNC	1.2	0.65	2.4	1.3	0.9	0.6	1.3	0.9	11Ft.Lbs	1/2"
RLP - M12	2.0	1.2	4.0	2.4	1.6	1.2	2.5	1.8	27 Nm	24 mm
RLP 1/2"-13 UNC	2.0	1.2	4.0	2.4	1.6	1.2	2.5	1.8	20Ft.Lbs	15/16"
RLP - M16	3.2	2.0	6.4	4.0	2.8	2.0	4.2	3.0	60 Nm	24 mm
RLP 5/8"-11 UNC	3.2	2.0	6.4	4.0	2.8	2.0	4.2	3.0	44Ft.Lbs	15/16"
RLP - M20	5.6	2.8	11.2	5.6	3.9	2.8	5.8	4.2	90 Nm	32 mm
RLP 3/4"-10 UNC	5.0	2.5	10.0	5.0	3.5	2.5	5.2	3.7	66Ft.Lbs	1 5/16"
RLP 7/8"-9 UNC	5.6	2.8	11.2	5.6	3.9	2.8	5.8	4.2	66Ft.Lbs	1 5/16"
RLP - M24	9.2	4.6	18.4	9.2	6.4	4.6	9.6	6.9	135 Nm	32 mm
RLP 1"-8 UNC	9.2	4.6	18.4	9.2	6.4	4.6	9.6	6.9	100Ft.Lbs	1 5/16"
RLP - M30	12.0	6.0	24.0	12.0	8.4	6.0	12.6	9.0	270 Nm	55 mm
RLP - M36	14.0	8.0	28.0	16.0	11.2	8.0	16.8	12.0	320 Nm	55 mm
RLP - M42	16.0	14.0	32.0	28.0	19.6	14.0	29.4	21.0	600 Nm	75 mm
RLP - M48	20.0	16.0	40.0	32.0	22.4	16.0	33.6	24.0	800 Nm	75 mm

DLP Fırdöndü Kaldırma Mapası Çalışma Yük Limitleri

Sapın bacak sayısı	1		2		2 simetrik		3 & 4 simetrik		Tork anahtarı	Allen anahtarı
	0°*	90°	0°	90°	0-45°	45-60°	0-45°	45-60°		
DLP -M8	0.35	0.35	0.70	0.70	0.49	0.35	0.74	0.53	10 Nm	13 mm
DLP 5/16"-18 UNC	0.35	0.35	0.70	0.70	0.49	0.35	0.74	0.53	7Ft.Lbs	1/2"
DLP -M10	0.65	0.65	1.30	1.30	0.91	0.65	1.37	0.98	15 Nm	13 mm
DLP 3/8"-16 UNC	0.60	0.60	1.20	1.20	0.84	0.60	1.26	0.90	11Ft.Lbs	1/2"
DLP -M12	1.0	1.0	2.0	2.0	1.4	1.0	2.1	1.5	27 Nm	24 mm
DLP 1/2"-13 UNC	1.0	1.0	2.0	2.0	1.4	1.0	2.1	1.5	20Ft.Lbs	15/16"
DLP -M16	1.8	1.8	3.6	3.6	2.5	1.8	3.7	2.7	60 Nm	24 mm
DLP 5/8"-11 UNC	1.6	1.6	3.2	3.2	2.2	1.6	3.3	2.4	44Ft.Lbs	15/16"

BLP Rulmanlı Fırdöndü Kaldırma Mapası Çalışma Yük Limitleri

Sapın bacak sayısı	1		2		2 simetrik		3 & 4 simetrik		Tork anahtarı	
	0°*	90°	0°	90°	0-45°	45-60°	0-45°	45-60°		
BLP -M8	0.60	0.30	1.20	0.42	0.60	0.42	0.30	0.63	0.45	10 Nm
BLP 5/16"-18 UNC	0.60	0.30	1.20	0.42	0.60	0.42	0.30	0.63	0.45	7Ft.Lbs
BLP -M10	1.20	0.60	2.40	0.84	1.20	0.84	0.60	1.26	0.90	15 Nm
BLP 3/8"-16 UNC	1.00	0.50	2.00	0.70	1.00	0.70	0.50	1.05	0.75	11Ft.Lbs
BLP -M12	1.50	0.75	3.0	1.05	1.50	1.05	0.75	1.53	1.13	27 Nm
BLP 1/2"-13 UNC	1.5	0.75	3.0	1.05	1.50	1.05	0.75	1.53	1.08	20Ft.Lbs
BLP -M16	3.0	1.5	6.0	2.10	3.0	2.1	1.5	3.1	2.2	60 Nm
BLP 5/8"-11 UNC	3.0	1.5	6.0	2.10	3.0	2.1	1.5	3.1	2.2	44Ft.Lbs
BLP -M20	5.0	2.5	10.0	3.50	5.0	3.5	2.5	5.2	3.7	90 Nm
BLP 3/4"-10 UNC	4.50	2.25	9.00	3.15	4.50	3.10	2.25	4.68	3.33	66Ft.Lbs
BLP 7/8"-9 UNC	6.0	3.0	12.00	4.20	6.0	4.2	3.0	6.3	4.5	66Ft.Lbs



	REL P	RLP	DLP	BLP
Dar alan	✓		✓	✓
Limitli yükseklik	✓	✓		
Diksey kaldırma	✓	✓		✓
Açılı kaldırma		✓	✓	✓
Yük altında diksey dönme hareketi				✓
Yük altında eğim		✓	✓	✓
Hassas yük yüzeyi				✓
Tek noktadan kaldırma	✓	✓		✓
Çok noktadan kaldırma		✓	✓	✓
Entegre uygulama (kanca veya halka)		✓		

Bu tablo uygulamaların için en uygun mapayı seçmenize yardımcı olur, kural niteliği taşımaz. Daha fazla bilgi almak için temsilcilerimiz ile irtibata geçiniz.



GUNNEBO
Industries



■ Varil Taşıyıcılar
Drum Lifters

VARİL
KALDIRMA - TAŞIMA EKİPMANLARI
DRUM LIFTING - HANDLING EQUIPMENTS

FORKLİFT ÇATAL KANCASI / FORK HOOK

NL-DHE 01

Art.No. 53000001

NL-DHE 01

Kapasite / Capacity	2500	kg
Max. çatal aralığı / Max. fork section	150 x 60	mm
Ağırlık / Weight	25	kg

- Saniyeler içerisinde bir forklifti bir vinçe çevirir.
- Çatalın uzunluğu boyunca kullanılabilir.
- Çatalara güvenlik vidası ile sabitlenir.
- Güvenlik mandallı fırdöndülü kanca.
- Converts a forklift truck into a mobile crane in seconds.
- Adjustable along the length of the fork.
- Secured to forks by thumb screw.
- Swivel hook includes safety latch.

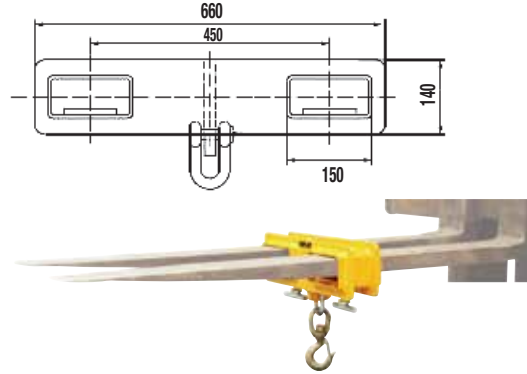

VARİL KALDIRMA SAPANI / DRUM LIFTER

NL-DHE 02

Art.No. 53000002

NL-DHE 02

Taşıma kapasitesi / Capacity (Tek/Çift, Single/Double)	500/ 1000	kg
Kanıtlanmış test yükü / Prove test load	2000	kg
Çap - Uzunluk / Diameter - Length	6.3/ 516	mm
Maks. varil çapı / Reach	690	mm
Ağırlık / Weight	3.6	kg



VARİL TAŞIMA ÇATALI / DRUM LIFTER

NL-DHE 03

Art.No. 53000003

NL-DHE 03

Kaldırma kapasitesi / Capacity	500	kg
Varil ölçüsü / Drum size	55	gallon
Ağırlık / Weight	7.5	kg



VARİL KALDIRMA VE BOŞALTMA ATAŞMANI (MANUEL) /
 VERTICAL DRUM LIFTERS-DISPENSERS (MANUAL TYPE)

Art.No. 53000004

NL-DHE 04

- Tek kişilik kullanımı sayesinde zamandan tasarruf sağlar, gereksiz zayıfatı engeller ve verimliliği artırır.
- Varil taşıma ekipmanını vinç kancasına veya kaldırma ekipmanı kancasına bağlayarak mekanizmayı varilin etrafına yerleştirin ve istenen yüksekliğe kaldırın.
- Açık veya kapalı varillerin taşınması, nakliyesi ve boşaltılmasında kullanılır.
- 363 kg' lik tam dolu veya 227 kg' ye kadar yarım dolu olan variller için.
- 55 Galonluk kapalı çelik varillere uygun.
- Kilit sistemi sayesinde varil dikey konumda iken kilitleyerek sabitlenebilir. 55 galonluk çelik variller ile kullanılır.
- Kullanıcı boşaltma işleminden sonra varili kendi eksenine etrafında 360 derece döndürerek varilin içini kontrol edebilir.
- Tüm bunların dışında varili yatay konumda da kapatır.
- Ölçüleri: 39" yükseklik x 281/2" genişlik x 8" çap.
- Net ağırlık 20kg / 44lbs.
- One-person Operation saves time, reduces spilling waste and improves productivity.
- Simply attach or hang lifter on hook from an overhead hoist or crane, cinch saddle around drum and raise to desired height and position.
- Lift, transport and pour from open and closed head drum.
- 800lbs. full drum, 500 lbs. half-full drum capacity.
- For 55-gallon closed steel drums.
- Idea for low lever pouring and dumping operations.
- Positive tilt lock on drum saddle to hold drum upright in transit.
- When released, the operator can manually tilt the drum to control pouring and the drum can be rotated 360° in either direction.
- Locks also hold drum in horizontal position.
- Overall dimensions: 39"H x 281/2" W x 8"D.
- Net weight 20 kg / 44lbs.

VARİL KALDIRMA VE BOŞALTMA ATAŞMANI (ZİNCİRLİ) /
 VERTICAL DRUM LIFTERS-DISPENSERS (GEARED TYPE)

Art.No. 53000005

NL-DHE 05

- Tek kişilik kullanımı sayesinde zamandan tasarruf sağlar, gereksiz zayıfatı engeller ve verimliliği artırır.
- Varil taşıma ekipmanını vinç kancasına veya kaldırma ekipmanı kancasına bağlayarak mekanizmayı varilin etrafına yerleştirin ve istenen yüksekliğe kaldırın.
- Açık veya kapalı varillerin taşınması, nakliyesi ve boşaltılmasında kullanılır.
- 363 kg' lik tam dolu veya 227 kg' ye kadar yarım dolu olan variller için.
- 55 Galonluk kapalı çelik varillere uygun.
- Uzaktan varil boşaltma işlemi için uygundur.
- Zincir kontrol sistemi sayesinde istenen yükseklikte rahatlıkla çalıştırılabilmektedir. 3m.'lik kilitlenebilen zinciri sayesinde varilin nakliye boşaltılmasında iş güvenliği sağlanmaktadır.
- Ölçüleri: 39" yükseklik x 281/2" genişlik x 8" çap.
- Net ağırlık 38kg / 84lbs.
- One-person Operation saves time, reduces spilling waste, and improves productivity.
- Simply attach or hang lifter on hook from an overhead hoist or crane, cinch saddle around drum, and raise to desired height and position.
- Lift, transport, and pour from open and closed head drum.
- 800 lbs. full drum, 500 lbs. half-full drum capacity.
- For 55-gallon closed steel drums.
- Allows remote pouring operations.
- Geared chain control and low effort feature make this model useable at any height. 10-ft control chain can be locked to secure drum in any position during transit and dispensing.
- Overall dimensions: 39"H x 281/2" W x 8"D.
- Net weight 38kg / 84lbs.



VARİL TAŞIMA ARABASI (MANUEL) / DRUM TRUCK

NL-DHE 06

Art.No. 53000006

NL-DHE 06

Kapasite / Capacity	450	kg
Varil ölçüsü / Drum size	30 - 55	gallon
Makine ölçüleri / Overall size	1520 x 600 x 1500	mm
Tekerlek / Wheel (Poliüretan/ Poly)	250 x 50	mm
Ağırlık / Weight	28	kg

- Tek operatörün rahatlıkla çalışma olanağı.
- Destek ayak sayesinde kendiliğinden durma imkanı.
- 245 mm'lik tekerler sayesinde az eforlu rahat kullanım.
- Güvenli fiçı taşıma ve muhafaza.

- One person can operate easily.
- Self-standing with kickstand.
- 245 mm rubber wheel let you operate with less effort.
- Safely carry and grip the drum.



ÇELİK VARİL YÜRÜTME ARABASI / STEEL DRUM DOLLIES

NL-DHE 07

NL-DHE 08

Art.No. 53000007

NL-DHE 07

Art.No. 53000008

NL-DHE 08

Kaldırma kapasitesi / Capacity	320	410	kg
Varil ölçüsü / Drum size	30	55	gallon
İç çap / Inside diameter	501	601	mm
Plastik destek tekerleri / Plastic swivel castor	76x30	76x30	mm
Ağırlık / Weight	7	9	kg



NL-DHE 07

NL-DHE 08

- Sessiz yürüyen ve kullanım kolaylığı sağlayan, özellikle 30 veya 55 galonluk varillerin nakliyesi için uygun bir araç.
- 1/8" x 2 1/8" çelik çevresi ve 3 1/8" çemberi olan variller için uygundur.
- Değiştirilebilir galvanizli bilyeli ağır yük tekerleri, 3x1 1/4" polyetilen kaplı olup, suya, yağa ve diğer dış etkenlere karşı dayanıklıdır.
- Galvanizli somun ve vidalar.

- Smooth rolling, strong and durable dollies easily transport 30 or 55 gallon drums.
- All welded 1/8" x 2 1/8" steel frame and 31/8" cross straps.
- Replaceable, heavy-duty zinc plated casters feature single race bearings with 3x1 1/4" polyolefin tread that resist oil, water and impact.
- Zinc plated nuts and bolts.

MEKANİK VARİL TRANSFER ARABASI / LOW PROFILE DRUM CADDY

NL-DHE 09

Art.No. 53000009

NL-DHE 09

Kapasite / Capacity	500	kg
Varil ölçüsü / Drum size	30	gallon
Makine ölçüleri / Overall size	950 x 570 x 750	mm
Tekerlek (poly) çap-genişlik / Wheel (poly) diameter - width	150 x 50 - 75 x 32	mm
Ağırlık / Weight	17	kg

- 30 - 55 galon çelik, plastik veya fiber varil taşıma için ideal çözüm.
- Varil kapaklarını açmak ya da varili yana eğme işlemlerini yapabileceğiniz sökülebilir kumanda kolu.

- Easily transport 30 or 55 gallon steel, plastic or fiber drums.
- Removable handle is used to tilt drum for position on dolly and features a built in bung nut wrench and seal remover.



VARİL PALETTEME ARACI / DRUM PALLETIZER**NL-DHE 10**

Art.No. 53000010

NL-DHE 10

Kapasite / Capacity	365	kg
Uygun varil tipi / Acceptable drum style	55 gallon, Çelik/ Steel	
Makine ölçüleri / Overall size	1160 x 1220 x 800	mm
Tekerlekler / Wheel	150 x 50, 100 x 32	mm
Ağırlık / Weight	85	kg

- Varillerin paletlerin yüklenmesinde ve indirilmesinde kullanılır.
- İkili mandal sistemi operatörün herhangi bir güç sarfetmeden ve yükü balansı etmeden fiçiyi sabit tutmasını sağlar.

- Moves and transports drums easily to or from pallets.
- Dual ratchet stops hold the weight of the drum, and provide several positions where the handle stays until operator holds no weight and does not need to balance drum truck.

**VARİL TRANSPALETİ / DRUM PICKER****NL-DHE 11**

Art.No. 53000011

NL-DHE 11

Kapasite / Capacity	365	kg
Varil ölçüsü / Drum size	55	galon
Maks. yükseklik / Max. height	390	mm
Min. yükseklik / Lowest height	270	mm
Makine ölçüleri / Overall size	1022x722	mm
Ağırlık / Weight	53	kg

**VARİL TAŞIMA ARABASI (HİDROLİK) / DRUM PICKER (HYDRAULIC)****NL-DHE 12**

Art.No. 53000012

NL-DHE 12

Kapasite / Capacity	250	kg
Kaldırma yüksekliği / Lifting height	280	mm
Maksimum varil çapı / Max. drum diameter	572	mm
Maksimum varil yüksekliği / Max. drum height	915	mm
Ağırlık / Weight	40	kg



VARİL BOŞALTMA ARACI / DRUM HANDLER

NL-DHE 13

Art.No. 53000013

NL-DHE 13

Kapasite / Capacity	364	kg
Varil ölçüsü / Drum size (55 gallon)	572	mm
Ağırlık / Weight	50	kg

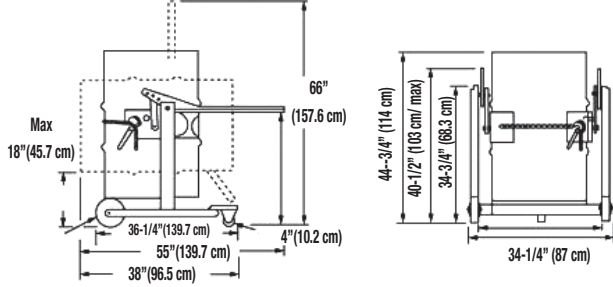

HİDROLİK VARİL PALET YÜKLEME ARACI / HYDRAULIC RIDE-ON DRUM TRUCK

NL-DHE 14

Art.No. 53000014

NL-DHE 14

Kapasite / Capacity	250	kg
Max. varil yüksekliği / Max. drum height	1180	mm
Min. varil yüksekliği / Min. drum height	910	mm
Birim strok / Lifting per stroke	22	mm
Varil ölçüsü / Drum size	572	mm
Ağırlık / Weight	50	kg

- 30 ve 55 galonluk varillerin paletler üzerine rahatlıkla yükleme ve boşaltmasını sağlar.
- Tutucu çenesi yardımı ile varili tek noktadan kavrar, kaldırır ve istenen noktaya taşınmasını sağlar.

- Easily glides over pallets to quickly load or unload 30 or 55-gallon drums.
- Grabs drums from the middle of a standard pallet with a drum clawgramp, raises the drums up and redistributes them throughout the facility.

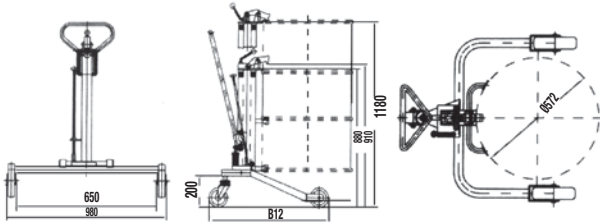

VARİL - PALET BOŞALTMA ARACI / HYDRAULIC DRUM TRUCK (STRADDLE LEG)

NL-DHE 15

Art.No. 53000015

NL-DHE 15

Kapasite / Capacity	250	kg
Kaldırma yüksekliği / Lifting height	345	mm
Birim strok / Lifting per stroke	22	mm
Varil ölçüsü / Drum size (55 gallon)	572	mm
Ağırlık / Weight	45	kg

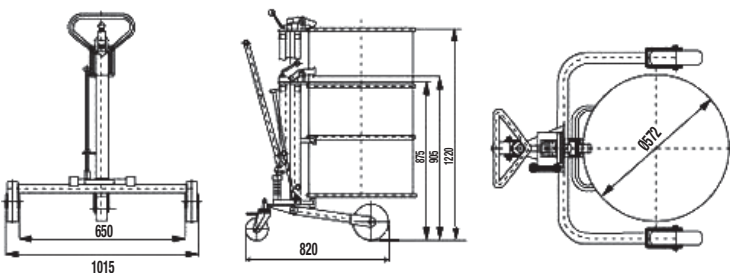

VARİL PALETLEME ARACI (Hidrolik) / RAPTOR DRUM LOADER-UNLOADER

NL-DHE 16

Art.No. 53000018

NL-DHE 16

Kapasite / Capacity	450	kg
Kaldırma yüksekliği / Lifting height	500	mm
Kaldırma başı yükseklik / Lifting per stroke	11.6	mm
Varil ölçüsü / Drum size	572	mm
Ağırlık / Weight	165	kg

- 30 veya 55 galonluk varilleri palet'ten yüklemek veya kaldırmak için kullanılır. Paletin ortasında bulunan varili tutucu çenesi yardımı ile kavrayarak kaldırır. Bu şekilde varilin istenen yere rahat ve sorunsuz bir şekilde taşınması sağlanır.
- Köşelerdeki variller bu ekipmanla rahatlıkla alınabilir. Polyester tekerleri sayesinde yüksek kullanım kolaylığı ve hareket kabiliyeti sağlar.
- Easily glides over pallet to quickly load or unload 30 or 55 gallon drums. Grabs drums from the middle of a standard pallet with a drum clawgrab, raises the drums up, and redistributes them throughout the facility.
- Also removes drum from the corner of containment skids. Highly maneuverable unit features a unique two poly wheel and two poly caster

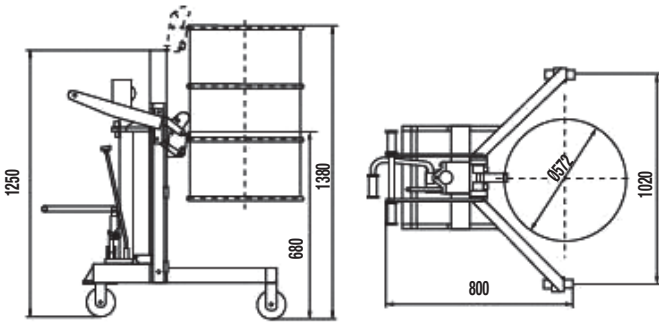

PALET UYUMLU HİDROLİK VARİL TAŞIMA ARACI / HYDRAULIC DRUM TRUCK

NL-DHE 17

Art.No. 53000017

NL-DHE 17

Kapasite / Lifting capacity	300	kg
Varil ölçüsü / Drum size	572mm (22.5 Diameter)	mm
	210 Lifters (55 gallon)	
Ön teker çap/genişlik / Front wheel Dia.x Width	64 x 37	mm
Arka teker çap/genişlik / Rear castor Dia.x Width	80 x 32	mm
H1 ölçüsü / Dimension H1	835	mm
H2 ölçüsü / Dimension H2	1640	mm
Toplam ölçü UxGxY / Overall Dimension LxWxH	866 x 956 x 1525	mm
Ağırlık / Weight	68	kg

- Poly, fiber ya da çelik varilleri paletlerden almak/ koymak için ergonomik çözüm.
- Yay etkili çene varili sıkıca kavrar.
- Kamyon ve kamyonetlere rahatça yükleme/indirme olanağı sağlayan kaldırma yüksekliği.
- Kompakt ve kullanımı kolaydır.
- Kolay montaj/ demontaj.

- Ergonomic lifts, transports, and places poly, steel, or fiber drums on or off pallets.
- A spring-loaded clamp securely holds any rimmed drum.
- High lifting height for ledge and car.
- Compact design and less effort operation.
- Disassembling easy and for small carton store.

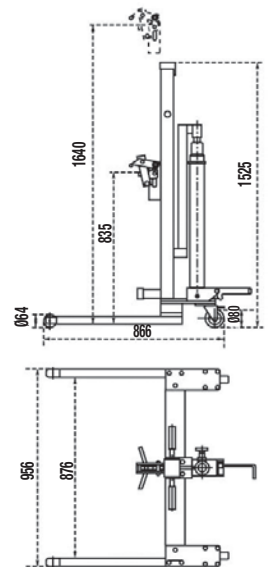

HİDROLİK VARİL TAŞIMA ARACI / HYDRAULIC DRUM TRUCK

NL-DHE 18

Art.No. 53000016

NL-DHE 18

Kapasite / Lifting capacity	300	kg
Varil ölçüsü / Drum size	572 mm (22.5 Diameter)	mm
	210 Lifters (55 gallon)	
Ön teker çap/ genişlik / Front wheel Dia.x Width	125 x 32	mm
Arka teker çap/ genişlik / Rear castor Dia.x Width	125 x 32	mm
H1 ölçüsü / Dimension	870	mm
H2 ölçüsü / Dimension	1675	mm
Toplam ölçü / Overall Dimension	952 x 956 x 1560	mm
Ağırlık / Weight	72	kg

- Polyester fiber ya da çelik varilleri paletlerden almak/ koymak için ergonomik çözüm.
- Yay etkili çene varili sıkıca kavrar.
- Kamyon ve kamyonetlere rahatça yükleme/indirme olanağı sağlayan kaldırma yüksekliği.
- Kompakt ve kullanımı kolaydır.
- Kolay montaj/ demontaj.

- Ergonomic lifts, transports, and places poly, steel, or fiber drums on or off pallets.
- A spring-loaded clamp securely holds any rimmed drum.
- High lifting height for ledge and car.
- Compact design and less effort operation.
- Easy to assemble and disassemble.

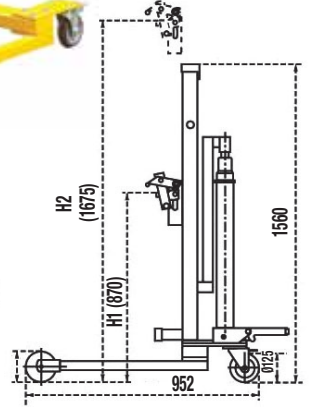
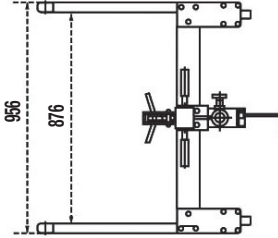

ERGONOMİK VARİL TAŞIYICI / ERGONOMIC DRUM HANDLER

NL-DHE 19

Art.No. 53000019

NL-DHE 19

Kapasite / Capacity	400	kg
Kaldırma yüksekliği / Lifting height	1070	mm
Anlık kaldırma yüksekliği / Lifting per stroke	11.6	mm
Varil ölçüsü / Drum size	55 - 80	gallon
Ağırlık / Weight	100	kg

- Ergonomik taşıyıcı çelik, polyester ve fiber varilleri paletlere yükler, indirir ve sevk eder.
- Yaylı kısıkaç sistemi yüklenen her varili sabit tutar.
- Kolay kullanım ve hizalama için dayanıklı ve üstün kaliteli rulmanlı yön tekerleri.
- Ayaklar değişik palet ölçülerine göre ayarlanabilir ve 55 - 85 galonluk variller için.

- Ergonomic lifts, transports and places poly, steel, or fiber drums on or off pallets.
- A spring-loaded clamp securely holds any rimmed drum.
- It has swivel steering wheels for easy positioning and precision roller bearing load wheels for maximum stability.
- Adjustable legs for different pallets. Handles 55-85 gallon drums.

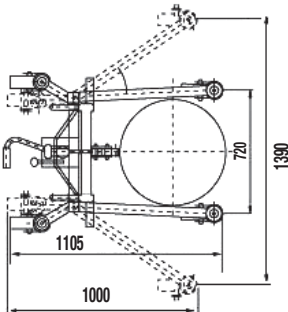
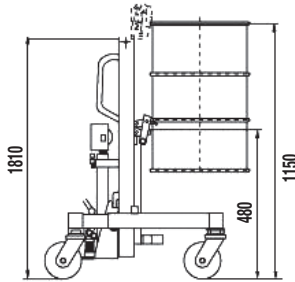

VARİL ÇEVİRME MAKİNESİ / TILTING BARREL STACKER

NL-DHE 20

Art.No. 51000016

NL-DHE 20

Kaldırma kapasitesi / Capacity	350	kg
Kaldırma yüksekliği / Lifting height	1425	mm
Makine boyu / Overall length	1190	mm
Makine genişliği / Overall width	890	mm
Makine yüksekliği / Overall height	2020	mm
Ağırlık / Weight	155	kg



- Polyester, çelik veya fiber varillerin palet üzerinden alınması / palet üzerine yerleştirilmesi, taşınması ve varilin boşaltılması işlemlerinin ergonomik olarak yerine getirilmesini sağlar. Döner sürüş tekerleri sayesinde manevra kabiliyeti kolaylaştırılmıştır. Kenarı çemberli her türlü varil tutucu çene yardımı ile rahatlıkla kaldırılabilir.

- Ergonomic lift, transport and handling of polyester, steel or fiber drums on or off pallet. It has swivel steering wheels for easy positioning. A spring loadclamp securely holds any rimmed drum.

YARI ELEKTRİKLİ VARİL ÇEVİRME MAKİNESİ / SEMI-ELECTRIC DRUM LIFT

NL-DHE 26

Art.No. 53000026

NL-DHE 26

Kaldırma kapasitesi / Capacity	350	kg
Kaldırma yüksekliği / Lifting height (H)	1450	mm
Kaldırma motoru / Lifting motor	12 / 1.6	V/kw
Makine boyu / Overall length (A)	1350	mm
Makine genişliği / Overall width (B)	930	mm
Makine yüksekliği / Overall height (H1)	2140	mm
Akü / Battery	12 / 120	V / Ah
Şarj cihazı / Charger	12 / 15	V / A
Ağırlık / Weight	310	kg

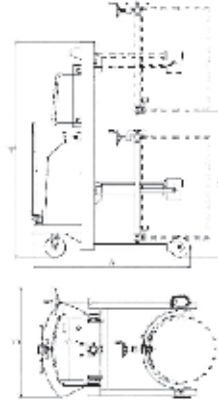

VARİL ELLEÇLEME ATAŞMANI / DRUM POSITIONER

NL-DHE 21

Art.No. 53000021

NL-DHE 21

Kapasite / Capacity	400	kg
Maksimum Çatal / Max. fork	140x50	mm
Çatal açıklığı / Fork spread	575	mm
Ölçüler / Overall size	1900x690x655	mm
Ağırlık / Weight	75	kg



210 litre çelik veya L ve XL çemberli varilleri elleçlemek içindir. Plastik variller yataydan dikeye ve dikeyden yataya hareket ettirilebilir. Varil dikey pozisyonda zemine indirildiğinde menteşeli kollar kilitletir. Dikey konumdaki varilleri aflara ve taşıma vasıtalarına istiflemek için ideal bir ekipmandır. Mekanik çalışma prensibine sahiptir. Operatör yerinden kalkmadan ekipmanı kumanda edebilir.

For manipulating 210 litre steel or L and XL reng. Plastic drums from horizontal to vertical and vice-versa. Hinged tines lock automatically when lowered to ground in horizontal position. Ideal for loadin/unloading drums stored horizontally on drum racking, stands and vehicles. Completely mechanical operation. Can be operated without the driver leaving the seat of the truck.

VARİL ELLEÇLEME ATAŞMANI / DRUM POSITIONER

NL-DHE 22

Art.No. 53000022

NL-DHE 22

Kapasite / Capacity	300	kg
Varil ölçüsü / Drum size	55 (210 litre)	gallon
Çatal açıklığı / Fork spread	623	mm
Ölçüler / Overall size	1405x720x120	mm
Ağırlık / Weight	42	kg



572 mm çapındaki çelik variller
Steel drum 572 mm diameter

Çatal cepleri : 140 mm x 55mm x 560 mm
Fork pockets : 140 mm x 55mm x 560 mm

VARİL KALDIRMA EKİPMANI / DRUM LIFTER

NL-DHE 23

Art.No. 53000023

NL-DHE 23

Kapasite / Capacity	500	kg
Açıklık / Opening	465	mm
Varil ölçüsü / Drum size	35	gallon
Ağırlık / Weight	10	kg

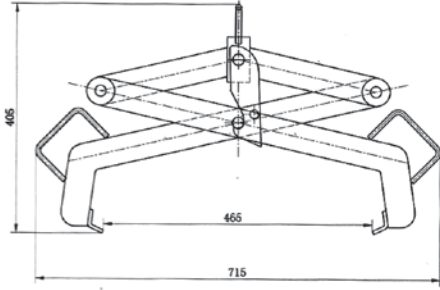

VARİL KALDIRMA EKİPMANI / DRUM LIFTER

NL-DHE 24

Art.No. 53000024

NL-DHE 24

Kapasite / Capacity	360	kg
Varil ölçüsü / Drum size	33,55	gallon
Varil / Drum	Plastik varil	
Ağırlık / Weight	7	kg



FORKLİFT VARİL ATAŞMANI / FORKLIF KARRIER

NL-DHE 25

Art.No. 53000020

NL-DHE 25

Kapasite / Lifting capacity	680	kg
Varil ölçüsü / Drum size	572mm (22.5 Diameter) 210 Lifters (55 gallon)	mm
Çatal açıklığı / Fork Opening	620	mm
Forklift cebi ölçüsü / Fork Pocket	65x180	mm
Ağırlık / Weight	97	kg

Varil kaldırma, taşıma ve çevirme işlemleri için ideal çözüm.
Drum lift, transport and tilting operations.





Merkez / Head Office :

Tel: 0090 (850) 333 43 00

Fabrika / Factory :

2. Organize Sanayi Bölgesi 9. Yol No. 4

54330 Hendek - Sakarya / TÜRKİYE

Tel. : 0090 (264) 654 50 57

Fax : 0090 (264) 654 56 44

e-mail : info@netmak.com.tr



www.netlift.com.tr

Yayın Tarihi: 2021