



- **Alüminyum Tek Direk Çalışma Platformları**
Single Mast Mobile Aluminum Work Platform
- **Alüminyum Çift Direk Çalışma Platformları**
Double Mast Mobile Aluminum Work Platform
- **Raf Yerleştirme / Sipariş Toplama Aracı**
Order Pickers
- **Akülü Makaslı Platformlar**
Powered Scissor Aerial Work Platform

PERSONEL YÜKSELTİCİLER
AERIAL WORK PLATFORM

ALÜMİNYUM TEK DİREK ÇALIŞMA PLATFORMU / SINGLE MAST MOBILE ALUMINUM WORK PLATFORM

	NL-SMAP 6.0	NL-SMAP 8.0	NL-SMAP 10.0		
Platform kapasitesi / Access platform capacity	150	125	125	kg	
Maksimum personel sayısı / Max. occupants	1	1	1		
Çalışma yüksekliği / Working height	8	10	12	m	
Platform yüksekliği / Platform floor height	6	8	10	m	
Makine boyu / Overall length	1.42	1.42	1.42	m	
Makine genişliği / Overall width	0.78	0.78	0.78	m	
Makine yüksekliği / Overall height	1.92	1.93	1.93	m	
Platform ölçüsü / Platform size	0.66 x 0.69			m	
Zemin açıklığı / Ground clearance	0.05			m	
Teker arası mesafesi / Wheelbase	1.12			m	
Kaldırma motoru / Lifting motor	AC	110 - 230 / 1.5		VAC/kW	
	DC	12 / 1.5		VDC/kW	
Kaldırma-indirme hızı / Up-down speed	36 / 33	40 / 36	45 / 36	s	
Arka tekerlekler / Back wheels	Ø 180x50	Ø 180x50	Ø 180x50	mm	
Ön tekerlekler / Front wheels	Ø 150x50	Ø 150x50	Ø 150x50	mm	
Akü / Battery					
Ağırlık / Weight	AC - DC	380 - 401	404 - 430	445 - 471	kg

ELEKTRİKLİ
ELECTRIC

Art.No. 51500130	NL-SMAP 6.0
Art.No. 51500006	NL-SMAP 8.0
Art.No. 51500007	NL-SMAP 10.0
Art.No. 51500059	NL-SMAP 6.0-1
Art.No. 51500060	NL-SMAP 8.0-1
Art.No. 51500061	NL-SMAP 10.0-1

AKÜLÜ
BATTERY

Standard ekipmanlar

- Ayarlanabilir denge ayakları
- Acil durum durdurma butonu
- Akü şarj göstergesi (Akülü modelde)
- Elektrik limit anahtarı
- Zeminden ve platformdan kontrol imkanı
- Acil durum indirme valfi
- Seviye göstergesi (su terazisi)
- Aşırı yük koruma
- Forklift cepleri
- Nakliye bağlama noktası

Standard equipment

- Swing out outriggers with interlock
- Emergency stop button
- Battery charge indicator
- Electric limit switch
- Grand & Platform (For battery powered)
- Emergency lowering system
- Leveling indicator
- Forklift pockets
- Transport tie hole

Opsiyonel seçenekler

- Aşırı yük sensörü
- Platformda elektrik prizi
- Tüm hareketlerde sesli uyarı
- Uyarı lambası
- Entegre şarj cihazı

Optional equipments

- Overload sensor with buzzer
- AC power to platform
- All motion alarm
- Beacon
- DC power with charger

(Opsiyonel) akülü modeller için müşteri temsilcileri ile irtibata geçiniz.
Please contact customer representative for (optional) battery powered models.

Elektrikli



Akülü

Entegre şarj cihazı

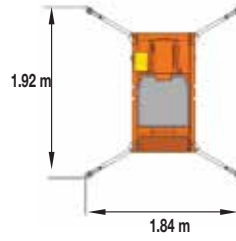

NL-SMAP : 1.92 m
NL-SMAP 8.0 : 1.93 m
NL-SMAP 10.0 : 1.93 m

NL-SMAP 6.0 : 8 m
NL-SMAP 8.0 : 10 m
NL-SMAP 10.0 : 12 m

NL-SMAP : 6 m
NL-SMAP 8.0 : 8 m
NL-SMAP 10.0 : 10 m



ALÜMİNYUM ÇİFT DİREK ÇALIŞMA PLATFORMU / DUAL MAST MOBILE ALUMINUM WORK PLATFORM

	NL-DMAP 6.0	NL-DMAP 8.0	NL-DMAP 10.0	NL-DMAP 12.0	NL-DMAP 14.0		
Platform kapasitesi / Access platform capacity	300	300	250	200	200	kg	
Maksimum personel sayısı / Max. occupants	2	2	2	2	2		
Çalışma yüksekliği / Working height	8	10	12	14	16	m	
Platform yüksekliği / Platform floor height	6	8	10	12	14	m	
Makine boyu / Overall length	1.53	1.53	1.79	1.79	1.86	m	
Makine genişliği / Overall width	0.82	0.82	0.82	0.87	0.95	m	
Makine yüksekliği / Overall height	1.81	1.81	1.86	2.03	2.3	m	
Platform ölçüsü / Platform size	1.28x0.66	1.28x0.66	1.54x0.66	1.54x0.66	1.48x0.62	m	
Zemin açıklığı / Ground clearance	0.08	0.08	0.08	0.08	0.06	m	
Teker mesafesi / Wheelbase	1.18	1.18	1.44	1.44	1.44	m	
Kaldırma motoru / Lifting motor	AC	110 - 230 / 1.5	110 - 230 / 1.5	110 - 230 / 1.5	110 - 230 / 1.5	VAC/kW	
	DC	12 / 1.5	12 / 1.5	12 / 1.5	12 / 1.5	24 / 1.5	VDC/kW
Kaldırma-indirme hızı / Up-down speed	0.062 / 0.043	0.062 / 0.043	0.070 / 0.046	0.075 / 0.054	0.073 / 0.058	m/sn	
Arka tekerlekler / Back wheels	Ø 200x50	Ø 200x50	Ø 200x50	Ø 200x50	Ø 150x50	mm	
Ön tekerlekler / Front wheels	Ø 200x50	Ø 200x50	Ø 200x50	Ø 200x50	Ø 150x50	mm	
Ağırlık / Weight	AC - DC	600 - 640	630 - 670	730 - 770	825 - 865	750 - 815	kg

ELEKTRİKLİ ELECTRIC	Art.No. 51500131	NL-DMAP 6.0
	Art.No. 51500008	NL-DMAP 8.0
	Art.No. 51500009	NL-DMAP 10.0
	Art.No. 51500010	NL-DMAP 12.0
	Art.No. 51500147	NL-DMAP 14.0
AKÜLÜ BATTERY	Art.No. 51500002	NL-DMAP 6.0-1
	Art.No. 51500005	NL-DMAP 8.0-1
	Art.No. 51500014	NL-DMAP 10.0-1
	Art.No. 51500021	NL-DMAP 12.0-1
	Art.No. 51500022	NL-DMAP 14.0-1

Standard ekipmanlar

- Ayarlanabilir denge ayakları
- Acil durum durdurma butonu
- Akü şarj göstergesi
- Elektrik limit anahtarı
- Zeminden ve platformdan kontrol imkanı
- Acil durum indirme valfi
- Seviye göstergesi (su terazisi)

Standard equipment

- Swing out outriggers with interlock
- Emergency stop button
- Battery charge indicator
- Electric limit switch
- Grand & Platform (For battery powered)
- Emergency lowering system
- Leveling indicator

Seçenekler

- Aşırı yük sensörü
- Platformda elektrik prizi
- Tüm hareketlerde sesli uyarı
- Uyarı lambası
- Entegre şarj cihazı

Options

- Overload sensor with buzzer
- AC power to platform
- All motion alarm
- Beacon
- DC power with charger

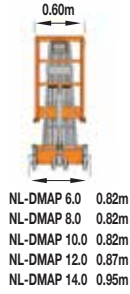
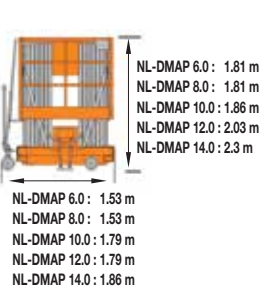

Akülü Entegre Şarj Cihazı

NL-DMAP 6.0: 8 m
NL-DMAP 8.0: 10 m
NL-DMAP 10.0: 12 m
NL-DMAP 12.0: 14 m
NL-DMAP 14.0: 16 m

NL-DMAP 6.0 6m
NL-DMAP 8.0 8m
NL-DMAP 10.0 10m
NL-DMAP 12.0 12m
NL-DMAP 14.0 14m



AKÜLÜ YÜRÜTMELİ TEK - ÇİFT DİREK ÇALIŞMA PLATFORMU / SINGLE-DOUBLE MAST ALUMINIUM WORK PLATFORM

Art.No. 51500025	NL-FEAP / S 6.0
Art.No. 51500026	NL-FEAP / S 7.5
Art.No. 51500027	NL-FEAP/D 7.5
Art.No. 51500028	NL-FEAP/D 9.0

	NL-FEAP/S 6.0	NL-FEAP/S 7.5	NL-FEAP/D 7.5	NL-FEAP/D 9.0	
Kaldırma kapasitesi / Capacity	150	125	200	150	kg
Maksimum personel sayısı / Max. occupants	1	1	1	1	
Çalışma yüksekliği / Working height	8.00	9.50	9.50	11	m
Platform yüksekliği / Platform height	6.00	7.50	7.50	9	m
Makine boyu / Overall length	1.40	1.40	1.55	1.55	m
Makine genişliği / Overall width	0.82	0.82	1.01	1.01	m
Makine yüksekliği / Overall height	1.98	1.98	2.00	2.00	m
Platform ölçüsü / Platform size	0.78 x 0.70	0.78 x 0.70	1.00 x 0.70	1.00 x 0.70	m
Platform genişletme ölçüsü / Platform extension size	0.55	0.55			m
Zemin açıklığı / Ground clearance	0.05	0.05	0.08	0.08	m
Teker mesafesi / Wheelbase	1.14	1.14	1.23	1.23	m
Dönme çapı / Turning radius (iç/dış, inside/outside)	0	0	0 / 1.9	0 / 1.9	m
Yürüyüş motoru / Driving motor	2 x 24/ 0.4	2 x 24/ 0.4	2 x 24/ 0.5	2 x 24/ 0.5	VDC/KW
Kaldırma motoru / Lifting motor	24/ 2	24/ 2	24/ 2	24/ 2	VDC/KW
Kapalı hız / Travel speed (stowed)	4	4	4	4	km/h
Açık hız / Travel speed (raised)	1.1	1.1	1.1	1.1	km/h
Kaldırma-indirme hızı / Up-down speed	43/ 35	48/ 40	42/ 31	45/ 34	s
Akü / Battery	2 x 12/ 120	2 x 12/ 120	2 x 12/ 120	2 x 12/ 120	V/Ah
Şarj cihazı / Integretad charger	24/ 10A	24/ 12	24/ 10	24/ 10	V/A
Eğim / Gradeability	25	25	25	25	%
Maksimum eğim / Maximum slope	1.5	1.5	2	2	°
Sürüş tekerleği / Drive wheels	230 x 80	230 x 80	305 x 100	305 x 100	mm
Ön tekerlekler / Front wheels	8	8			in
Ağırlık / Weight	914	940	1270	1345	kg

Standard ekipmanlar

- Hassas kontroller
- Otomatik engel koruması
- Platformda kendinden kapanır kapı
- Maks. yükseklikte hareket imkanı
- İz bırakmayan tekerlek
- 2WD
- Otomatik fren sistemi
- Acil durum indirme valfi
- Akü şarj göstergesi
- Acil durdurma butonu
- Hidrolik emniyet valfi
- Platformda hata göstergesi
- Eğim alarmı
- Tüm hareketlerde sesli uyarı
- Korna
- Saat sayacı
- Forklift çepçeri
- Şarj koruması
- Flaşlı uyarı lambası
- Şaşıden ve platformdan kumanda

Standard equipment

- Proportional controls
- Automatic pothole protection
- Self-closing gate on platform
- Drivable at full height
- Non-marking tyre
- 2WD
- Automatic brake system
- Emergency lowering system
- Emergency stop button
- Cylinder holding valve
- Onboard diagnostic system
- Tilt sensor with alarm
- All motion alarm
- Horn
- Hour meter
- Forklift pockets
- Charger protection
- Flashing beacon
- Operation at chassis and platform

Seçenekler

- Aşırı yük uyarısı
- Platformda elektrik prizi
- Platform çalışma ışığı
- Platformda hava hattı

Options

- Overload sensor with buzzer
- AC power to platform
- Platform work lights
- Airline to platform



Opsiyonel / Optional:
Genişletilmiş platform / Extended platform



NL-FEAP/D 1.01 m
NL-FEAP/S 0.82 m

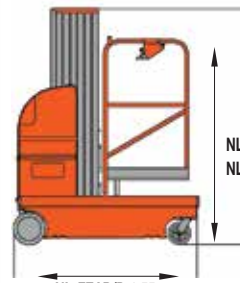

NL-FEAP/D 1.55 m
NL-FEAP/S 1.40 m

NL-FEAP/D 2.0 m
NL-FEAP/S 1.98 m



NL-FEAP / S



NL-FEAP / D

NL-FEAP/D 7.5 : 9.5 m
NL-FEAP/D 9.0 : 11 m
NL-FEAP/S 6.0 : 8 m
NL-FEAP/S 7.5 : 9.5 m

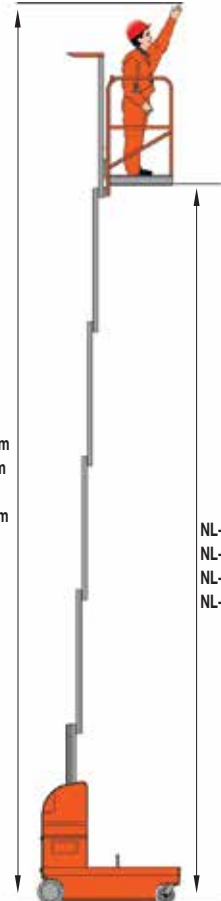

NL-FEAP/D 7.5 : 7.5 m
NL-FEAP/D 9.0 : 9 m
NL-FEAP/S 6.0 : 6 m
NL-FEAP/S 7.5 : 7.5 m



Acil Durum İndirme Sistemi



Forklift Çepleri



Eğim



Dar Alanlarda Manevra
Kabiliyeti



Uyarı
Lambası



Acil Durum İndirme
Sistemi

AKÜLÜ YÜRÜTMELİ RAF YERLEŞTİRME MAKİNESİ (3 mastlı) / ELECTRIC AERIAL ORDER PICKER (3 masts)

	NL-OPP 3.5/3 FE	NL-OPP 4.0/3 FE	NL-OPP 4.5/3 FE	
Kaldırma kapasitesi / Capacity	300	300	300	kg
Maksimum personel sayısı / Max. occupants	1	1	1	
Çalışma yüksekliği / Working height	5.50	6.00	6.50	m
Platform yüksekliği / Platform Floor height	3.50	4.00	4.50	m
Makine boyu / Overall length	1.56	1.56	1.56	m
Makine genişliği / Overall width	0.76	0.76	0.76	m
Makine yüksekliği / Overall height	1.64	1.81	1.99	m
Platform ölçüsü / Platform size	0.93 x 0.70	0.93 x 0.70	0.93 x 0.70	m
Zemin açıklığı / Ground clearance	0.04	0.04	0.04	m
Teker mesafesi / Wheelbase	1.23	1.23	1.23	m
Dönme yarıçapı / Turning radius	1.72	1.72	1.72	m
Sürüş motoru / Drive motors	2 x 24/ 0.4	2 x 24/ 0.4	2 x 24/ 0.4	VDC/kW
Kaldırma Motoru / Lifting motor	24/ 2	24/ 2	24/ 2	VDC/kW
Kapalı hız / Travel speed (stowed)	4	4	4	km/h
Açık hız / Travel speed (raised)	1.1	1.1	1.1	km/h
Kaldırma-indirme hızı / Up-down speed	20 / 18	22 / 19	24 / 21	m/sn
Akü / Battery	2 x 12/ 120	2 x 12/ 120	2 x 12/ 120	V/Ah
Şarj cihazı / Integretad charger	24/ 10	24/ 10	24/ 10	V/A
Eğim / Gradeability	25	25	25	%
Sürüş tekerleği / Drive wheels	Ø 230 x 80	Ø 230 x 80	Ø 230 x 80	mm
Ön tekerlekler / Front wheels	6	6	6	in
Ağırlık / Weight	642	662	682	kg

Art.No. 51500098	NL-OPP 3.5/3 FE
Art.No. 51500099	NL-OPP 4.0/3 FE
Art.No. 51500100	NL-OPP 4.5/3 FE

Standard ekipmanlar

- Hassas kontroller
- Platformda kendinden kapanır kapı
- Maks. yükseklitte hareket imkanı
- İz bırakmayan tekerlek
- 2WD
- Otomatik fren sistemi
- Acil durum indirme valfi
- Acil durdurma butonu
- Hidrolik emniyet valfi
- Platformda hata göstergesi
- Forklift cepleri
- Şarj koruması

Seçenekler

- Aşırı yük uyarısı
- Platform çalışma ışığı
- Tüm hareketlerde sesli uyarı
- Çalışma saati
- İkaz lambası
- Akü şarj göstergesi

Standard equipment

- Proportional controls
- Self-closing gate on platform
- Drivable at full height
- Non-marking tyre
- 2WD
- Automatic brake system
- Emergency lowering system
- Emergency stop button
- Cylinder holding valve
- Onboard diagnostic system
- Forklift pockets
- Charger protection

Options

- Overload sensor with alarm
- Platform work lights
- All motion buzzer
- Hour meter
- Flashing beacon
- Charge indicator



NL-OPP 3.5/3 FE : 5.50 m
NL-OPP 4.0/3 FE : 6.00 m
NL-OPP 4.5/3 FE : 6.50 m

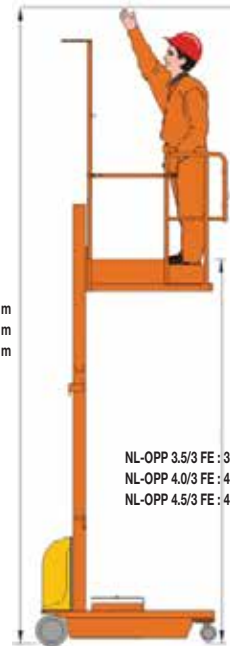

Akülü kaldırma / Akülü yürütme

PERSONEL YÜKSELTİCİLER
Aerial Work Platforms



Forklift Çepleri



Platformda Kendinden Kapanır Kapı



Acil Durum İndirme Sistemi



Mekanik Durdurucu

SİPARİŞ TOPLAMA ARACI / ORDER PICKER

		NL-OPP 3 PRO	NL-OPP 3.6 PRO	NL-OPP 4 PRO	NL-OPP 4.8 PRO	
Güç / Power		Elektrikli	Elektrikli	Elektrikli	Elektrikli	
Operatör tipi / Operator type		Ayakta	Ayakta	Ayakta	Ayakta	
Ön platform kapasitesi / Rated capacity on front platform	Q1	227	227	227	227	kg
Arka platform kapasitesi / Rated capacity on behind platform	Q2	137	137	137	137	kg
Operatör platformu / Rated capacity on standing platform	Q3	136	136	136	136	kg
Tekerlek mesafesi / Wheelbase	y	1150	1150	1150	1256	mm
Ağırlık (akü dahil) / Service weight (include battery)		1160	1230	1340	1530	kg
Aksa binen yük (sürüş tarafı / yükleme tarafı) yüklü / Axle loading (laden driving side/loading side)		680/980	710/1020	740/1100	780/1220	kg
Aksa binen yük (sürüş tarafı / yükleme tarafı) yüksüz / Axle loading (unladen driving side/loading side)		490/670	500/730	520/820	540/990	kg
Tekerlek türü (yürüyüş / yük) / Tyre type (driving/loading)		Poliüretan	Poliüretan	Poliüretan	Poliüretan	
Sürüş tekeri ölçüsü (çap x genişlik) / Tyre type, driving wheels (dia. x width)		Ø 230x75	Ø 230x75	Ø 230x75	Ø 230x75	mm
Yük tekeri ölçüsü (çap x genişlik) / Tyre type, loading wheels (dia. x width)		Ø 204x76	Ø 204x76	Ø 204x76	Ø 204x76	mm
Denge tekeri ölçüsü (çap x genişlik) / Tyre type, caster wheels(dia. x width)		Ø 74x48	Ø 74x48	Ø 74x48	Ø 74x48	mm
Tekerlek sayısı (yön/yük) / Wheels, number driving, caster/loading (x=drive wheels)		1x 2/2	1x 2/2	1x 2/2	1x 2/2	
Ön tekerlekler arası mesafe / Tread, front	b10	566	566	566	626	mm
Arka tekerlekler arası mesafe / Tread, rear	b11	724	724	724	784	mm
Maks. ön platform yüksekliği / Lift height	h3	2950	4432	3850	4630	mm
Mast açık yükseklik / Height, mast extended	h4	4540	4490	5970	6750	mm
Mast kapalı yüksekliği / Height of overhead guard	h6	1590	1590	2120	2120	mm
Operatör platformu kapalı yükseklik / Seat height / standing height	h7	250	250	250	250	mm
Operatör platformu açık yükseklik / Stand height, elevated	h12	3200	3600	4100	4880	mm
Makine uzunluğu / Overall length	l1	1500	1500	1500	1610	mm
Makine genişliği / Overall width	b1/b2	800	800	800	860	mm
Zemin açıklığı / Ground clearance, center of wheel base	m2	50	50	50	50	mm
Ön platform ölçüsü / Front cargo platform width		800x520	800x520	800x520	800x520	mm
Ön platform kapalı yüksekliği / Initial height of front cargo platform		-	-	-	-	mm
Kontrol kolu yüksekliği / Control handle height		-	-	-	-	mm
Arka platform ölçüsü / Behind platform width		346x660	346x660	346x660	346x660	mm
Platform dahil makine uzunluğu / Overall length platform launch	l3	1795	1795	1795	1905	mm
Koridor genişliği / The channel width	Ast	1750	1750	1750	1840	mm
Dönme yarıçapı / Turning radius	Wa	1385	1385	1385	1450	mm
h12: 0-520mm'de yürüyüş hızı (yüklü / yüksüz) / Travel speed (laden/unladen)		5.5	5.5	5.5	5.5	km/h
h12: 520-1940mm'de yürüyüş hızı (yüklü / yüksüz) / Travel speed (laden/unladen)		3.7	3.7	3.7	3.7	km/h
h12: 1940-2600mm'de yürüyüş hızı (yüklü / yüksüz) / Travel speed (laden/unladen)		2.5	2.5	2.5	2.5	km/h
h12: 2600mm üzeri yürüyüş hızı (yüklü / yüksüz) / Travel speed (laden/unladen)		1	1	1	1	km/h
h12: 0-520mm'de geri yürüyüş hızı (yüklü / yüksüz) / Travel speed (laden/unladen) backwards		5.5	5.5	5.5	5.5	km/h
h12: 520-1940mm'de geri yürüyüş hızı (yüklü / yüksüz) / Travel speed (laden/unladen) backwards		3.7	3.7	3.7	3.7	km/h
h12: 1940-2600mm'de geri yürüyüş hızı (yüklü / yüksüz) / Travel speed (laden/unladen) backwards		2.5	2.5	2.5	2.5	km/h
h12: 2600mm üzeri geri yürüyüş hızı (yüklü / yüksüz) / Travel speed (laden/unladen) backwards		1	1	1	1	km/h
Kaldırma hızı (yüklü / yüksüz) / Lifting speed (laden/unladen)		0.17 / 0.21	0.17 / 0.21	0.17 / 0.21	0.17 / 0.21	m/sn
İndirme hızı (yüklü / yüksüz) / Lowering speed (laden/unladen)		0.35 / 0.26	0.35 / 0.26	0.35 / 0.26	0.35 / 0.26	m/sn
Eğim (yüklü / yüksüz) / Max. gradeability (laden/unladen)		0	0	0	0	%
Fren tipi / Service brake		Elektromanyetik	Elektromanyetik	Elektromanyetik	Elektromanyetik	
Yürüyüş motoru / Drive motor rating S2 60 min.		1.7	1.7	1.7	1.7	kW
Kaldırma motoru / Lift motor rating at S3 15%		2.2	2.2	2.2	2.2	kW
Akü / Battery voltage/nominal capacity K20		24 / 224	24 / 224	24 / 224	24 / 280	V/Ah
Akü ağırlığı / Battery weight		163	163	163	250	kg
Sürüş kontrol tipi / Type of drive control		AC	AC	AC	AC	
Direksiyon tasarımı / Steering design		Elektronik	Elektronik	Elektronik	Elektronik	
Gürültü seviyesi / Sound pressure level at the driver's ear		74	74	74	74	dB (A)

*3600mm ve sonrası kaldırma yüksekliklerinde ön platformun kapasitesi 72 kg'dır.

PROFESYONEL SERİ

SİPARİŞ TOPLAMA ARACI / ORDER PICKER PLATFORM

Art.No. 51500182

NL-OPP 3 PRO

Art.No. 51500183

NL-OPP 4 PRO

Art.No. 51500184

NL-OPP 4.8 PRO

Tek parça kapak bakım amacıyla güç aktarım elemanlarına ulaşılabilmesi açısından büyük kolaylık sağlar.

Single piece cover provides great convenience in terms of reaching power transmission elements for maintenance.

Ekstra büyük ön yük platformu.
Extra large front capacity.

AC tahrikli elektronik direksiyon sezgisel ve hassas bir manevra kabiliyeti sağlar.
AC driven electronic steering provides intuitive and precise maneuverability.

Dayanıklı çelik gövde arka saklama tepsinini muhafaza etmekle beraber yükselmiş haldeyken üstün bir denge sağlanabilmesi için i-profil kanal direğini destekler.

Durable steel body retains the rear storage tray. It also supports i-profile channel post for superior stability when it's raised.



Yandan raylı sistem ile kolay çıkabilen akü
Easy removable battery with side rail system.

Özel AGM akü grubu 220 V şarj cihazı ile birlikte şarj edilebilmeyi desteklemekte ve 4 saate kadar kesintisiz çalışma süresi sunmaktadır.

Special AGM battery pack supports charging with a 200 V charger. It also provides up to 4 hours of continuous working.

250 mm lik alçak basamak yüksekliği araca binerken ve araçtan inerken kolaylık sağlar.

The low step height of 250 mm provides comfort when getting in and out of the vehicle.

HARİCİ ŞARJ CİHAZI

EXTERNAL CHARGER

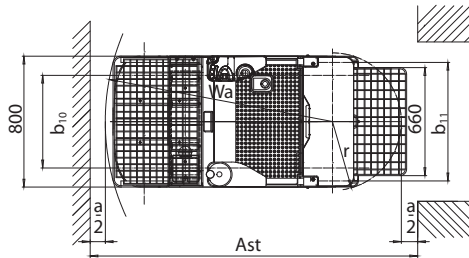

Yük arabası standart olmayıp opsiyonel aksesuardır. Çekilecek malzemeye göre özel olarak tasarlanabilir.



LCD ÖN PANEL EKRANI
(4 FARKLI HIZ SEÇİMİ)



ERGONOMİK BUTONLAR
KUMANDA

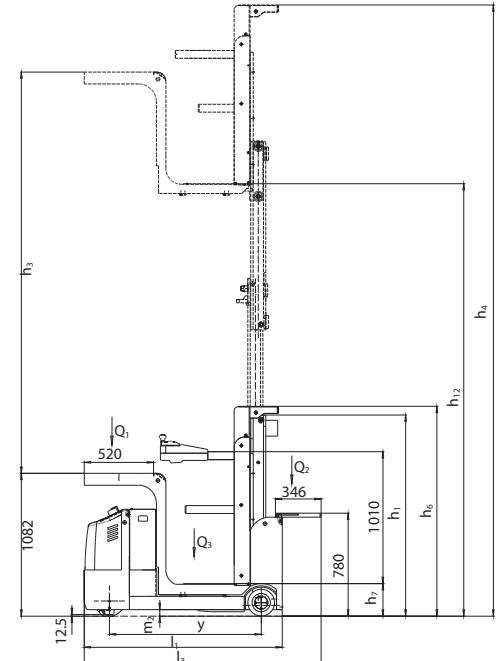

MAKASLI PLATFORM (Manuel yürütme) / SCISSOR LIFT PLATFORM

	NL-MP 3060	NL-MP 3090	NL-MP 3011	
Platform kapasitesi / Access platform capacity	300	300	300	kg
Çalışma yüksekliği / Working height	8	11	13	m
Platform yüksekliği / Platform floor height	6	9	11	m
Makine boyu / Overall length	1900	2250	2250	mm
Makine genişliği / Overall width	1070	1070	1420	mm
Makine yüksekliği / Overall height	0.95	1.5	1.6	m
Platform ölçüsü / Platform size	1.78 x 0.84	2.1 x 1.0	2.1 x 1.2	m
Platform uzatma / Platform extension	800	800	800	mm
Zemin açıklığı (teker merkezi) / Ground clearance	220	220	200	mm
Teker mesafesi / Wheelbase	850	900	1200	mm
Kaldırma motoru / Lifting motor	380 / 50	380 / 50	380 / 50	V/Hz
	1,5	1,5	2,2	kW
Kaldırma-indirme süresi / Up-down speed	44	72	73	sn
Voltaj / Voltage	380	380	380	V/AC
	elektrikli	elektrikli	elektrikli	
Arka tekerlekler / Back wheels	400 x 90	400 x 90	500 x 80	mm
Ön tekerlekler / Front wheels	400 x 90	400 x 90	500 x 80	mm
Ağırlık / Weight	750	1200	1500	kg

Art.No. 51500011	NL-MP 3060
Art.No. 51500012	NL-MP 3090
Art.No. 51500013	NL-MP 3011

Standard ekipmanlar

- Ayarlanabilir denge ayakları
- Mekanik durdurucu
- Acil durum indirme butonu
- Genişletilmiş platform
- Acil durum durdurma butonu
- Seviye göstergesi (su terazisi)
- Dolgu teker

Standard equipment

- Leveling outrigger device
- Safety brackets
- Emergency down button
- Extended platform
- Emergency stop button
- Leveling indicator
- Solid wheel

Elektrikli Kaldırma Manuel Yürütme

Electric Lifting Manual Travelling



- Dolgu teker



- Platform genişletme



- Arazi şartlarına uygun tekerler

- Çekici yardımıyla platform nakli

MAKASLI PLATFORM (Manuel yürütme) / SCISSOR LIFT PLATFORM

NL-MP 5011 PLUS

Platform kapasitesi / Access platform capacity	500 kg
Platform uzatma kapasitesi / S.W.L on extension	112 kg
Çalışma yüksekliği / Working height	13.5 m
Platform yüksekliği / Platform floor height	11.5 m
Makine boyu / Overall length	3.70 m
Makine genişliği / Overall width	1.68 m
Makine kapalı yüksekliği / Overall height	2.58 m
Platform ölçüsü / Platform size	2.50 x 1.12 m
Zemin açıklığı (teker merkezi) / Ground clearance	0.20 m
Teker mesafesi / Wheelbase	1.09 m
Platform genişletme ölçüsü / Platform extension size	1.27 m
Kaldırma motoru / Lifting motor	24/ 3 VDC/kW
Kaldırma-indirme süresi / Up-down speed	0.89 / 0.83 sn
Akü / Battery	4 x 6/ 210 V/Ah
Şarj cihazı / Integretad charger	24/ 25 V/A
Tekerlekler / Wheels	6.5 / 10
Ağırlık / Weight	2200 kg

Standard ekipmanlar

- Ayarlanabilir denge ayakları
- Akü şarj göstergesi
- Yüksek kapasiteli deepcycle aküler
- Mekanik durdurucu
- Forklift çepeleri
- Acil durum indirme valfi
- Genişletilebilir platform
- Acil durum durdurma butonu
- Seviye göstergesi (su terazisi)
- Aşırı yük koruma

Standard equipment

- Leveling outrigger device
- Battery charge indicator
- Deep cycle type batteries
- Safety brackets
- Forklift pockets lowering
- Emergency system
- Extended platform
- Emergency stop button
- Leveling indicator
- Over loading limitation



- Çekici yardımıyla platform nakli



- Katlanabilir korkuluk sistemi



- Yandan açılır akü hazneleri

Akülü Kaldırma Manuel Yürütme

Battery Lifting Manual Travelling



- Platform uzatma

- Mekanik durdurucu

- Arazi şartlarına uygun tekerler

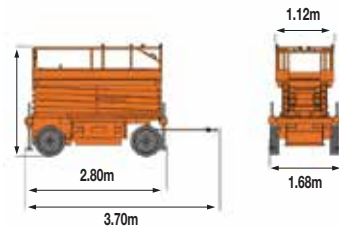

NL-MP 5011 PLUS 11.5 13.5m

MP 5011 PLUS
11.5 2.58m

AKÜLÜ MAKASLI PLATFORM / Powered SCISSOR AERIAL WORK PLATFORM

	NL-SEL 6.0 DC	NL-SEL 8.0 HD	NL-SEL 8.0 HD DAR	NL-SEL 10.0 HD	NL-SEL 12.0 HD	NL-SEL 14.0 HD	
Kaldırma kapasitesi / Capacity	230	450	230	320	320	200	kg
Platform uzatma kapasitesi / S.W.L on extension	113	113	113	113	113	113	kg
Maks. personel sayısı (platform içinde/uzatma) / Max. workers number (indoor / outdoor)	2/1	2/1	2	2/1	3	2	-
Çalışma yüksekliği / Working height (h2)	7.8	10	10	12	14	15.7	m
Platform yüksekliği / Platform height (h1)	5.8	8	8	10	12	13.7	m
Makine boyu / Overall length (L1)	1.885	2.48	2.48	2.48	2.48	2.84	m
Makine genişliği / Overall width (w1)	0.76	1.15	0.81	1.15	1.15	1.25	m
Makine yüksekliği / Overall height (rails up) (h4)	2.18	2.32	2.36	2.44	2.58	2.58	m
Makine yüksekliği (korkuluk kapalı) / Overall height (rails down) (h3)	1.78	1.78	1.93	1.92	2.04	2.17	m
Platform ölçüsü / Platform size	1.67 x 0.74	2.27 x 1.12	2.27 x 0.81	2.27 x 1.12	2.27 x 1.12	2.64 x 1.02	m
Platform uzama mesafesi / Platform extension size	0.9	0.9	0.9	0.9	0.9	0.9	m
Zemin açıklığı (kapalı) / Ground clearance (stowed)	0.07	0.10	0.10	0.10	0.10	0.10	m
Zemin açıklığı (açık) / Ground clearance (raised)	0.015	0.019	0.019	0.019	0.019	0.019	m
Tekerlek mesafesi / Wheelbase	1.37	1.87	1.87	1.87	1.87	2.22	m
Dönme çapı / Turning radius (iç/dış, inside/outside)	1.75	2.5	2.2	2.5	2.5	2.5	m
Kaldırma motoru / Lifting motors	24-2.0	24-4.5	24-3.3	24-4.5	24-4.5	24-4.5	V / kW
Sürüş motoru / Driving motors	24-0.5	24-4.5	24-3.3	24-4.5	24-4.5	24-4.5	V / kW
Yürüyüş hızı (kapalı) / Travel speed (stowed)	4.5	3.2	3.2	3.2	3.2	3.2	km/h
Yürüyüş hızı (açık) / Travel speed (raised or extended)	0.8	0.8	0.8	0.8	0.8	0.8	km/h
Kaldırma-indirme süresi / Up-down speed	20 / 32	27/36	32/35	48 / 48	80 / 60	70 / 52	s
Akü / Battery	4 x 6 / 220	4 x 6 / 232	4 x 6 / 232	4 x 6 / 232	4 x 6 / 280	4 x 12 / 310	V / Ah
Şarj cihazı / Integretad charger	24 / 30	24 / 30	24 / 30	24 / 30	24 / 30	24 / 30	V / Ah
Tırmanma (ön/yan) / Gradeability (front/side)	25	25	25	25	25	25	%
Maksimum eğim / Maximum slope	1.5 / 3	2 / 3	1.5 / 3	2 / 3	1.5 / 3	1.5 / 3	°
Tekerlekler / Tires	Ø 305 x 100	Ø 381 x 127	Ø 381 x 127	Ø 381 x 127	Ø 381 x 127	Ø 381 x 127	mm
Ağırlık / Weight	1510	2655	2275	2890	2925	3375	kg

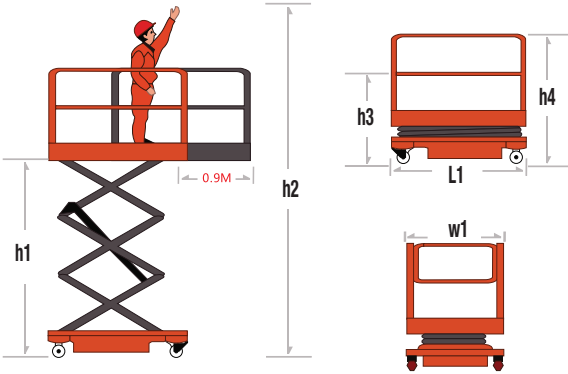

DAHİLİ ŞARJ CİHAZI INTERNAL CHARGER



Art.No. 51500139

NL-SEL 6.0 DC

Art.No. 51500120

NL-SEL 8.0 HD

Art.No. 51500120-1

NL-SEL 8.0 HD DAR

Art.No. 51500121

NL-SEL 10.0 HD

Art.No. 51500019

NL-SEL 12.0 HD

Art.No. 51500020

NL-SEL 14.0 HD

Standard ekipmanlar

- Hassas kontroller
- Otomatik kilitlenen platform kapısı
- Tek yönlü platform uzatması
- Tam yükseklikte sürüş
- İz bırakmayan tekerlek
- Hidrolik sürüş motoru(HD)
- Otomatik fren sistemi
- Acil durum indirme valfi
- Acil durdurma butonu
- Hidrolik emniyet valfi
- Arıza teşhis sistemi
- Eğitim koruma sistemi
- Eğitim alarmı
- Korna
- Çalışma saati
- Bakım güvenlik kolu
- Forklift cepleri
- Şarj koruması
- Uyarı lambası
- Katlanabilir korkuluk
- Engel koruması
- Şaşiden ve platformdan kumanda

Opsiyonel Seçenekler

- Aşırı yük uyarısı
- Platformda elektrik prizi
- Platform çalışma aydınlatması
- Platformda hava hattı

Standard equipment

- Proportional controls
- Platform self-locking door
- One-way extension platform
- Full height travel
- Solid tire
- Hydraulic motor driving (HD)
- Automatic brakes
- Emergency lowering system
- Emergency stop button
- Oil line explosion-proof system
- Fault diagnostic system
- Inclined protection system
- Motion buzzer
- Horn
- Hour meter
- Safety maintenance support bar
- Forklift pockets
- Charger protection
- Warning beacon
- Integrated foldable guardrail
- Pot hole protection system
- Operation at chassis and platform

Options

- Overload sensor
- AC line to platform
- Platform working light
- Pneumatic line



Hata kodu göstergesi



Şarj Koruma Sistemi
Akü dolunca otomatik olarak şarjı sonlandırır



Kablolu joystick kumanda



İz Bırakmayan Teker



Ana Güç Anahtarı
Park halinde kapalı tutulmalıdır



Acil Durum İndirme Sistemi



Katlanabilir korkuluk



Otomatik Kilitlenen Platform Kapısı



Otomatik Fren Sistemi



Tek yönlü platform uzatma

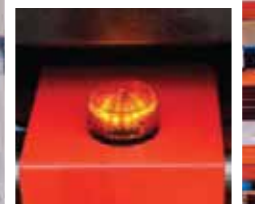

Uyarı lambası



Joystick üzerinde



Tüm komponentlere kolay erişim



NET MAK®
METAL MAKİNA SANAYİ VE TİCARET LTD. ŞTİ.

**SAC VE AHŞAP PLAKA, RULO, KİRİŞ,
RAY, BORU, VARİL, BLOK, PROFİL,
BOBİN, MAKARA VE BENZERİ
ÖZEL KALDIRMA UYGULAMALARI**

İŞ GÜVENLİĞİ YÖNETMELİKLERİNE UYGUN, SERTİFİKALI ÜRÜNLER

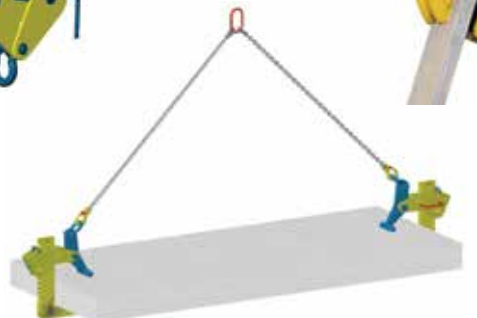
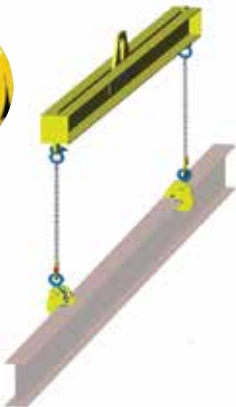
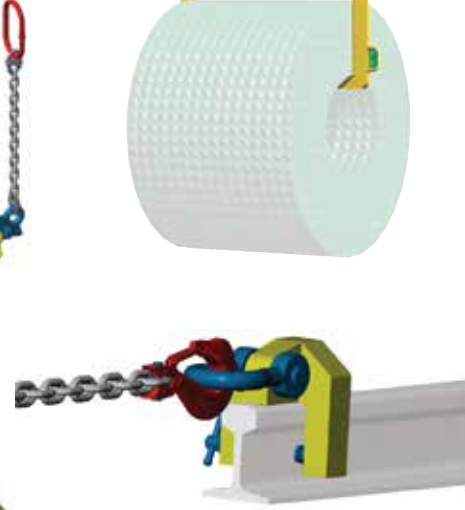
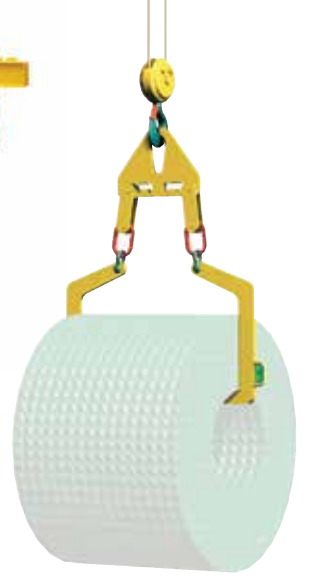

0850
333
4300



www.netmak.com.tr

